

25/30/35BH-9

Electric Counterbalance Trucks

MOVING YOU FURTHER

HYUNDAI MATERIAL HANDLING



*Photo may include optional equipment.

Your satisfaction is **our priority!**

Hyundai introduces a new line of 9-series battery forklift trucks. The newly designed four wheel counter-balance trucks provide operators increased comfort, productivity and ease of maintenance.



■ Some of the photos may include optional equipment.

Compact forklift with proven AC technology

- Maximum performance
- Comfortable operating room
- Battery side loading system
- Curve control system
- Fingertip controlled mini levers available (optional)
- Load Weight Indicator
- Speed Limit Function
- 3.5 inch LCD color Monitor



High Efficiency & Optimal Performance



More efficient operating control levers (Optional)

Electronic directional control and secondary horn are mounted to the hydraulic lift lever for quick and precise maneuvering.



Finger tip control levers (Optional)

Ergonomically designed fingertip control levers for improved operator comfort and productivity.



■ Some of the photos may include optional equipment.



Advanced drive and lift performance with proven durability and low maintenance

The enclosed drive and pump motor with AC technology combine power, extended maintenance intervals and excellent durability. The brushless AC motors offer improved efficiency and reduction maintenance cost.

Efficient, smooth running and powerful performance make your work more productive.

25/30/35BH-9



■ Some of the photos may include optional equipment.

Curve control

Curve Control limits travel speed based on turning radius, reducing speed for a smooth, precise turning operation for the driver.



Driving Speed

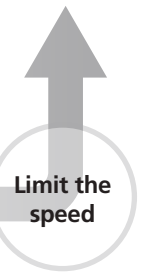

Dual drive system

Using a dual drive system will minimise aisle width and energy consumption. Plus, the drive units and AC motors intergrated in the front axle provide the operator with extremely improved gradient capacity.



Auto fork leveling system (Optional)

In order to improve productivity the auto fork leveling system will stop automatically when the forks are level.



Max.Gradeability (loaded)

Model	%
25BH-9	26
30BH-9	22
35BH-9	19

Max.Travel Speed (Unloaded)

Model	Km / h
25BH-9	19
30BH-9	19
35BH-9	19

Anti roll back system, travel speed and gradeability

Anti Roll-back system offers protection against the machine rolling back on a ramp in combination with exceptional ramp start capabilities.

Advanced **Safety**



■ Some of the photos may include optional equipment.

Excellent visibility for safe operation

Optimized lift cylinder arrangement provides operator with wider visibility.



Panoramic mirror

The panoramic mirror expands the driver's view when backing up.

Strong overhead guard

Exceeding ISO 6055 and ANSI regulations, the overhead guard offers great protection combined with excellent all around visibility.

The safely designed driver's space makes your operating more comfortable.

25/30/35BH-9

Fork safety features

When the forks are being lowered, a down-control valve maintains the controlled speed. The down-safety valve prevents forks from dropping down in case of sudden damage of hydraulic line.

OPSS(Operator Presence Sensing System)

When operator is not in seat the hydraulic lift and tilt controls and travel are locked out.

Lift Lock Tilt Lock Drive Lock

■ Some of the photos may include optional equipment.



Safety lamps & rear reflectors

LED combination lights and halogen headlights offer the driver visibility in all circumstances. Rear reflectors mounted on the counterweight enhance safety for the driver and the application.

Optimised Ergonomics & Fast and Easy Maintenance



Spacious operator cabin

The newly designed cabin was conceived for more space, a wider field of view and operator comfort.

■ Some of the photos may include optional equipment.



Optimized pedal position and floor mat

The position of accelerator and brake have been optimized through human engineering.

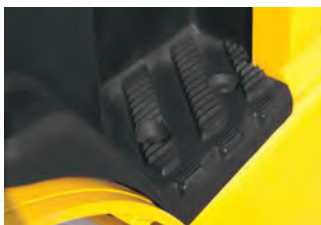

Large entrance step

Wide and non-slip step offers convenience and safety when entering and exiting truck.

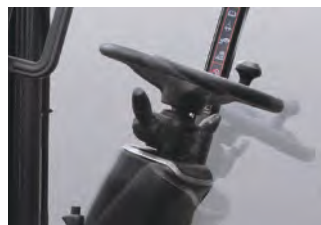

Adjustable steering wheel

The angle of the steering column can easily be adjusted to improve operator comfort.



Grammer seat

An adjustable ergonomic seat provides unmatched comfort. The adjustable armrest further reduces operator fatigue.

An ideal arrangement of components ensures easy access and convenience for maintenance.

25/30/35BH-9



Advanced LCD Monitor

■ Some of the photos may include optional equipment.

The LCD color monitor with 3.5 inch graphic smart display allows the operator to easily and efficiently control the machine. The monitor provides information about speed level, steer angle & travel direction, battery discharge indicator, hour meter & working mode. The load indicator displays the load weight in the monitor. The operator can select various performance modes to meet all working conditions. It is available multi-languages (maximum 11) for operator.

H (High) mode **N** (Normal) mode **E** (Economic) mode **Turtle mode**



Easy battery replacement

The battery compartment is equipped with a side battery removal assembly for easy removal and replacement.



Brake oil reservoir with level sensor

The enhanced brake oil reservoir, located in the upper left dash, is equipped with an electronic level sensor and easily visible through the monitor.

New 9 Series

Mast Specification (25BH-9)

Mast Type	Maximum Fork Height		Overall Height (Lowered)		Free Lift Height						Tilt Angle		Load capacity w/o side shift		Load capacity w/side shift		Truck Weight (Unloaded)		
					With Load Backrest		Without Load Backrest		Without Load Backrest (3/4-SPOOL)		Fwd	Bwd	24 in LC	500mm LC	24 in LC	500mm LC			
	in	mm	in	mm	in	mm	in	mm	in	mm	deg	deg	lb	kg	lb	kg	lb	kg	
2-Stage Limited free lift	V300	118.3	3,005	79.2	2,012	4.5	115	4.5	115	4.5	115	6	8	5,000	2,500	5,000	2,500	10,341	4,691
	※V330	130.1	3,305	85.1	2,162	4.5	115	4.5	115	4.5	115	6	8	5,000	2,500	5,000	2,500	10,384	4,710
	V350	138.0	3,505	89.1	2,262	4.5	115	4.5	115	4.5	115	6	8	5,000	2,500	5,000	2,500	10,421	4,727
	V370	145.9	3,705	95.0	2,412	4.5	115	4.5	115	4.5	115	6	8	5,000	2,500	5,000	2,475	10,470	4,749
	V400	157.7	4,005	100.9	2,562	4.5	115	4.5	115	4.5	115	6	8	5,000	2,500	5,000	2,425	10,518	4,771
	V430	169.5	4,305	106.8	2,712	4.5	115	4.5	115	4.5	115	6	6	5,000	2,450	4,950	2,375	10,625	4,820
	V450	177.4	4,505	112.7	2,862	4.5	115	4.5	115	4.5	115	6	6	4,950	2,400	4,800	2,325	10,691	4,849
	V470	185.2	4,705	116.6	2,962	4.5	115	4.5	115	4.5	115	6	6	4,900	2,360	4,750	2,285	10,723	4,864
V500	197.0	5,005	122.5	3,112	4.5	115	4.5	115	4.5	115	6	6	4,850	2,350	4,700	2,275	10,771	4,886	
2-Stage full free lift	VF/VS295	117.2	2,976	79.2	2,012	32.8	832	54.3	1,379	54.3	1,379	6	6	5,000	2,500	5,000	2,500	10,474	4,751
	VF/VS325	129.0	3,276	85.1	2,162	38.7	982	60.2	1,529	60.2	1,529	6	6	5,000	2,500	5,000	2,500	10,547	4,784
	VF/VS345	136.9	3,476	89.1	2,262	42.6	1,082	64.1	1,629	64.1	1,629	6	6	5,000	2,500	5,000	2,475	10,620	4,817
3-Stage full free lift	TF370	145.9	3,705	71.3	1,812	24.9	632	44.2	1,122	42.6	1,081	6	6	5,000	2,500	5,000	2,475	10,663	4,837
	TF400	157.7	4,005	75.3	1,912	28.8	732	48.1	1,222	46.5	1,181	6	6	5,000	2,500	5,000	2,425	10,707	4,857
	TF430	169.5	4,305	79.2	2,012	32.8	832	52.0	1,322	50.4	1,281	6	6	5,000	2,450	4,950	2,375	10,753	4,878
	TF450	177.4	4,505	83.1	2,112	36.7	932	56.0	1,422	56.0	1,422	6	6	4,950	2,400	4,800	2,325	10,800	4,899
	TF470	185.2	4,705	85.1	2,162	38.7	982	58.0	1,472	56.3	1,431	6	6	4,850	2,350	4,700	2,275	10,825	4,910
	TF500	197.0	5,005	89.1	2,262	42.6	1,082	61.9	1,572	60.3	1,531	6	6	4,100	1,880	4,050	1,850	10,879	4,935
	TF550	216.7	5,505	96.9	2,462	50.5	1,282	69.8	1,772	69.8	1,772	6	6	3,400	1,550	3,150	1,430	10,965	4,974
	TF600	236.4	6,005	104.8	2,662	58.3	1,482	77.6	1,972	77.6	1,972	6	6	3,050	1,400	2,800	1,280	11,046	5,011
	TF650	256.1	6,505	112.7	2,862	66.2	1,682	81.1	2,061	71.3	1,810	3	3	2,950	1,350	2,700	1,230	11,160	5,062
	TF700	275.8	7,005	120.6	3,062	74.1	1,882	89.0	2,261	79.1	2,010	3	3	2,500	1,150	2,050	930	11,246	5,101
	TS370	145.9	3,705	71.3	1,812	24.9	632	44.2	1,122	42.3	1,074	6	6	5,000	2,500	5,000	2,475	10,663	4,837
	TS400	157.7	4,005	75.3	1,912	28.8	732	48.1	1,222	46.2	1,174	6	6	5,000	2,500	5,000	2,425	10,707	4,857
	TS430	169.5	4,305	79.2	2,012	32.8	832	52.0	1,322	50.2	1,274	6	6	5,000	2,450	4,950	2,375	10,753	4,878
	TS450	177.4	4,505	83.1	2,112	36.7	932	56.0	1,422	56.0	1,422	6	6	4,950	2,400	4,800	2,325	10,800	4,899
	TS470	185.2	4,705	85.1	2,162	38.7	982	58.0	1,472	56.1	1,424	6	6	4,850	2,350	4,700	2,275	10,825	4,910
	TS500	197.0	5,005	89.1	2,262	42.6	1,082	61.9	1,572	60.0	1,524	6	6	4,100	1,880	4,050	1,850	10,879	4,935
	TS550	216.7	5,505	96.9	2,462	50.5	1,282	69.8	1,772	69.8	1,772	6	6	3,400	1,550	3,150	1,430	10,965	4,974
TS600	236.4	6,005	104.8	2,662	58.3	1,482	77.6	1,972	77.6	1,972	6	6	3,050	1,400	2,800	1,280	11,046	5,011	
TS650	256.1	6,505	112.7	2,862	66.2	1,682	80.9	2,054	70.7	1,796	3	3	2,950	1,350	2,700	1,230	11,160	5,062	
TS700	275.8	7,005	120.6	3,062	74.1	1,882	88.7	2,254	78.6	1,996	3	3	2,500	1,150	2,050	930	11,246	5,101	
4-Stage full free lift	QF610	240.7	6,115	84.5	2,147	38.1	967	59.6	1,514	57.6	1,462	3	3	3,500	1,600	3,250	1,480	11,632	5,276
	QF660	260.4	6,615	92.4	2,347	45.9	1,167	67.5	1,714	65.4	1,662	3	3	3,050	1,400	2,800	1,280	11,764	5,336
	QF700	276.2	7,015	96.3	2,447	49.9	1,267	71.4	1,814	69.4	1,762	3	3	2,400	1,100	2,150	980	11,831	5,366
	QF745	293.9	7,465	102.2	2,597	55.8	1,417	75.4	1,915	67.4	1,713	3	3	1,750	800	1,500	680	11,932	5,412
	QF790	311.6	7,915	108.1	2,747	61.7	1,567	75.4	1,915	61.5	1,563	3	3	1,300	600	1,050	480	12,154	5,513

※ TS-Mast : Wide Visible 3-Stage Full Free Lift Mast with 2 Free Lift Cylinders.

* Standard



Mast Specification (30BH-9)

Mast Type		Maximum Fork Height		Overall Height (Lowered)		Free Lift Height						Tilt Angle		Load capacity w/o side shift		Load capacity w/side shift		Truck Weight Unloaded)	
						With Load Backrest		Without Load Backrest		Without Load Backrest (3/4-SPOOL)		Fwd	Bwd	24 in LC	500mm LC	24 in LC	500mm LC		
		in	mm	in	mm	in	mm	in	mm	in	mm	deg	deg	lb	kg	lb	kg		
2-Stage Limited free lift	V300	118.3	3,005	79.2	2,012	4.5	115	4.5	115	4.5	115	6	8	6,000	3,000	6,000	3,000	11,263	5,109
	※V330	130.1	3,305	85.1	2,162	4.5	115	4.5	115	4.5	115	6	8	6,000	3,000	6,000	3,000	11,310	5,130
	V350	138.0	3,505	89.1	2,262	4.5	115	4.5	115	4.5	115	6	8	6,000	3,000	6,000	3,000	11,350	5,148
	V370	145.9	3,705	95.0	2,412	4.5	115	4.5	115	4.5	115	6	8	6,000	3,000	6,000	3,000	11,402	5,172
	V400	157.7	4,005	100.9	2,562	4.5	115	4.5	115	4.5	115	6	8	6,000	3,000	6,000	3,000	11,454	5,196
	V430	169.5	4,305	106.8	2,712	4.5	115	4.5	115	4.5	115	6	6	6,000	3,000	6,000	3,000	11,565	5,246
	V450	177.4	4,505	112.7	2,862	4.5	115	4.5	115	4.5	115	6	6	6,000	3,000	6,000	2,950	11,635	5,277
	V470	185.2	4,705	116.6	2,962	4.5	115	4.5	115	4.5	115	6	6	6,000	3,000	6,000	2,875	11,669	5,293
	V500	197.0	5,005	122.5	3,112	4.5	115	4.5	115	4.5	115	6	6	6,000	2,900	6,000	2,775	11,721	5,317
2-Stage full free lift	VF/VS295	117.2	2,976	79.2	2,012	32.8	832	51.9	1,317	51.9	1,317	6	6	6,000	3,000	6,000	3,000	11,340	5,144
	VF/VS325	129.0	3,276	85.1	2,162	38.7	982	60.2	1,467	57.8	1,467	6	6	6,000	3,000	6,000	2,950	11,411	5,176
	VF/VS345	136.9	3,476	89.1	2,262	42.6	1,082	61.7	1,567	61.7	1,567	6	6	6,000	3,000	6,000	2,875	11,484	5,209
3-Stage full free lift	TF370	145.9	3,705	71.3	1,812	24.9	632	44.0	1,117	42.6	1,081	6	6	6,000	3,000	6,000	3,000	11,624	5,273
	TF400	157.7	4,005	75.3	1,912	28.8	732	47.9	1,217	46.5	1,181	6	6	6,000	3,000	6,000	3,000	11,670	5,294
	TF430	169.5	4,305	79.2	2,012	32.8	832	51.9	1,317	50.4	1,281	6	6	6,000	3,000	6,000	2,950	11,768	5,338
	TF450	177.4	4,505	83.1	2,112	36.7	932	55.8	1,417	55.8	1,417	6	6	6,000	3,000	6,000	2,875	11,778	5,343
	TF470	185.2	4,705	85.1	2,162	38.7	982	57.8	1,467	56.3	1,431	6	6	6,000	2,950	6,000	2,825	11,805	5,355
	TF500	197.0	5,005	89.1	2,262	42.6	1,082	61.7	1,567	60.3	1,531	6	6	4,950	2,250	4,800	2,180	11,860	5,380
	TF550	216.7	5,505	96.9	2,462	50.5	1,282	69.6	1,767	69.6	1,767	6	6	3,850	1,750	3,450	1,570	11,956	5,423
	TF600	236.4	6,005	104.8	2,662	58.3	1,482	77.4	1,967	77.4	1,967	6	6	3,200	1,450	2,800	1,270	12,049	5,465
	TF650	256.1	6,505	112.7	2,862	66.2	1,682	81.1	2,061	71.5	1,815	3	3	3,080	1,400	2,690	1,220	12,161	5,516
	TF700	275.8	7,005	120.6	3,062	74.1	1,882	89.0	2,261	79.3	2,015	3	3	2,650	1,200	2,250	1,020	12,247	5,555
	TS370	145.9	3,705	71.3	1,812	24.9	632	44.0	1,117	41.5	1,053	6	6	6,000	3,000	6,000	3,000	11,624	5,273
	TS400	157.7	4,005	75.3	1,912	28.8	732	47.9	1,217	45.4	1,153	6	6	6,000	3,000	6,000	3,000	11,670	5,294
	TS430	169.5	4,305	79.2	2,012	32.8	832	51.9	1,317	49.3	1,253	6	6	6,000	3,000	6,000	2,950	11,768	5,338
	TS450	177.4	4,505	83.1	2,112	36.7	932	55.8	1,417	55.2	1,403	6	6	6,000	3,000	6,000	2,875	11,778	5,343
	TS470	185.2	4,705	85.1	2,162	38.7	982	57.8	1,467	55.2	1,403	6	6	6,000	2,950	6,000	2,825	11,805	5,355
	TS500	197.0	5,005	89.1	2,262	42.6	1,082	61.7	1,567	59.2	1,503	6	6	4,950	2,250	4,800	2,180	11,860	5,380
	TS550	216.7	5,505	96.9	2,462	50.5	1,282	69.6	1,767	69.0	1,753	6	6	3,850	1,750	3,450	1,570	11,956	5,423
	TS600	236.4	6,005	104.8	2,662	58.3	1,482	77.4	1,967	76.9	1,953	6	6	3,200	1,450	2,800	1,270	12,049	5,465
	TS650	256.1	6,505	112.7	2,862	66.2	1,682	80.0	2,033	69.3	1,759	3	3	3,080	1,400	2,690	1,200	12,161	5,516
TS700	275.8	7,005	120.6	3,062	74.1	1,882	87.9	2,233	77.1	1,959	3	3	2,650	1,200	2,250	1,020	12,247	5,555	
4-Stage full free lift	QF610	240.7	6,115	84.5	2,147	38.1	967	57.2	1,452	57.2	1,452	3	3	3,750	1,700	3,350	1,520	12,485	5,663
	QF660	260.4	6,615	92.4	2,347	45.9	1,167	65.0	1,652	65.0	1,652	3	3	3,300	1,500	2,900	1,320	12,616	5,723
	QF700	276.2	7,015	96.3	2,447	49.9	1,267	69.0	1,752	74.9	1,902	3	3	2,650	1,200	2,250	1,020	12,683	5,753
	QF745	293.9	7,465	102.2	2,597	55.8	1,417	74.9	1,902	69.8	1,772	3	3	1,980	900	1,580	720	12,784	5,799
	QF790	311.6	7,915	108.1	2,747	61.7	1,567	75.8	1,925	64.8	1,645	3	3	1,540	700	1,150	520	13,006	5,900

※ TS-Mast : Wide Visible 3-Stage Full Free Lift Mast with 2 Free Lift Cylinders.

* Standard



New 9 Series

Mast Specification (35BH-9)

Mast Type	Maximum Fork Height		Overall Height (Lowered)		Free Lift Height						Tilt Angle		Load capacity w/o side shift		Load capacity w/side shift		Truck Weight Unloaded)		
					With Load Backrest		Without Load Backrest		Without Load Backrest (3/4-SPOOL)		Fwd	Bwd	24 in LC	500mm LC	24 in LC	500mm LC			
	in	mm	in	mm	in	mm	in	mm	in	mm	deg	deg	lb	kg	lb	kg	lb	kg	
2-Stage Limited free lift	V300	118.3	3005	82.4	2093	4.5	115	4.5	115	4.5	115	6	8	7,000	3,500	7,000	3,500	12,306	5,582
	※V330	130.1	3,305	88.3	2,243	4.5	115	4.5	115	4.5	115	6	8	7,000	3,500	7,000	3,500	12,357	5,605
	V350	138.0	3,505	92.2	2,343	4.5	115	4.5	115	4.5	115	6	8	7,000	3,500	7,000	3,500	12,398	5,624
	V370	145.9	3,705	98.1	2,493	4.5	115	4.5	115	4.5	115	6	8	7,000	3,500	7,000	3,500	12,451	5,648
	V400	157.7	4,005	104.1	2,643	4.5	115	4.5	115	4.5	115	6	8	7,000	3,500	7,000	3,430	12,503	5,671
	V430	169.5	4,305	110.0	2,793	4.5	115	4.5	115	4.5	115	6	6	7,000	3,500	7,000	3,350	12,615	5,722
	V450	177.4	4,505	115.9	2,943	4.5	115	4.5	115	4.5	115	6	6	7,000	3,450	7,000	3,300	12,685	5,754
	V470	185.2	4,705	119.8	3,043	4.5	115	4.5	115	4.5	115	6	6	7,000	3,400	6,810	3,250	12,719	5,770
V500	197.0	5,005	125.7	3,193	4.5	115	4.5	115	4.5	115	6	6	6,920	3,300	6,620	3,150	12,772	5,793	
2-Stage full free lift	VF/VS295	117.2	2,976	82.4	2,093	35.9	913	54.2	1,377	54.2	1,377	6	6	7,000	3,500	7,000	3,500	12,385	5,618
	VF/VS325	129.0	3,276	88.3	2,243	41.9	1,063	60.1	1,527	60.1	1,527	6	6	7,000	3,500	7,000	3,430	12,458	5,651
	VF/VS345	136.9	3,476	92.2	2,343	45.8	1,163	64.1	1,627	64.1	1,627	6	6	7,000	3,500	7,000	3,350	12,531	5,684
3-Stage full free lift	TF370	145.9	3,705	74.5	1,893	28.1	713	46.3	1,177	46.3	1,177	6	6	7,000	3,500	7,000	3,430	12,742	5,780
	TF400	157.7	4,005	78.5	1,993	32.0	813	50.3	1,277	50.3	1,277	6	6	7,000	3,500	7,000	3,350	12,795	5,804
	TF430	169.5	4,305	82.4	2,093	35.9	913	54.2	1,377	54.2	1,377	6	6	7,000	3,450	7,000	3,300	12,856	5,832
	TF450	177.4	4,505	86.3	2,193	39.9	1,013	58.1	1,477	58.1	1,477	6	6	7,000	3,400	7,000	3,250	12,911	5,856
	TF470	185.2	4,705	88.3	2,243	41.9	1,063	60.1	1,527	60.1	1,527	6	6	7,000	3,350	6,760	3,200	12,948	5,873
	TF500	197.0	5,005	92.2	2,343	45.8	1,163	64.1	1,627	64.1	1,627	6	6	5,840	2,650	5,500	2,500	12,997	5,895
	TF550	216.7	5,505	100.1	2,543	53.7	1,363	71.9	1,827	71.9	1,827	6	6	5,250	2,380	4,950	2,250	13,094	5,940
	TF600	236.4	6,005	108.0	2,743	61.5	1,563	79.8	2,027	79.8	2,027	6	6	3,750	1,700	3,400	1,550	13,189	5,983
	TF650	256.1	6,505	115.9	2,943	69.4	1,763	86.7	2,201	81.1	2,061	3	3	3,500	1,590	3,200	1,450	13,302	6,034
	TF700	275.8	7,005	123.7	3,143	77.3	1,963	94.5	2,401	89.0	2,261	3	3	2,950	1,350	2,750	1,250	13,388	6,073
	TS370	145.9	3,705	74.5	1,893	28.1	713	46.3	1,177	46.3	1,177	6	6	7,000	3,500	7,000	3,430	12,742	5,780
	TS400	157.7	4,005	78.5	1,993	32.0	813	50.3	1,277	50.3	1,277	6	6	7,000	3,500	7,000	3,350	12,795	5,804
	TS430	169.5	4,305	82.4	2,093	35.9	913	54.2	1,377	54.2	1,377	6	6	7,000	3,450	7,000	3,300	12,856	5,832
	TS450	177.4	4,505	86.3	2,193	39.9	1,013	58.1	1,477	58.1	1,477	6	6	7,000	3,400	7,000	3,250	12,911	5,856
	TS470	185.2	4,705	88.3	2,243	41.9	1,063	60.1	1,527	60.1	1,527	6	6	7,000	3,350	6,760	3,200	12,948	5,873
	TS500	197.0	5,005	92.2	2,343	45.8	1,163	64.1	1,627	64.1	1,627	6	6	5,840	2,650	5,500	2,500	12,997	5,895
	TS550	216.7	5,505	100.1	2,543	53.7	1,363	71.9	1,827	71.9	1,827	6	6	5,250	2,380	4,950	2,250	13,094	5,940
	TS600	236.4	6,005	108.0	2,743	61.5	1,563	79.8	2,027	79.8	2,027	6	6	3,750	1,700	3,400	1,550	13,189	5,983
TS650	256.1	6,505	115.9	2,943	69.4	1,763	85.6	2,173	80.0	2,033	3	3	3,500	1,590	3,200	1,450	13,302	6,034	
TS700	275.8	7,005	123.7	3,143	77.3	1,963	93.4	2,373	87.9	2,233	3	3	2,950	1,350	2,750	1,250	13,388	6,073	
4-Stage full free lift	QF610	240.7	6,115	85.0	2,158	40.0	1,017	57.4	1,459	57.4	1,459	3	3	4,200	1,920	3,950	1,800	14,565	6,607
	QF660	260.4	6,615	92.8	2,358	47.9	1,217	65.3	1,659	65.3	1,659	3	3	3,800	1,720	3,500	1,600	14,697	6,667
	QF700	276.2	7,015	96.8	2,458	51.9	1,317	69.3	1,759	69.3	1,759	3	3	3,100	1,410	2,850	1,300	14,764	6,697
	QF745	293.9	7,465	102.7	2,608	57.8	1,467	75.2	1,909	74.1	1,882	3	3	2,420	1,100	2,200	1,000	14,865	6,743
	QF790	311.6	7,915	108.6	2,758	63.7	1,617	80.1	2,035	74.1	1,882	3	3	1,750	800	1,550	700	15,087	6,843

※ TS-Mast : Wide Visible 3-Stage Full Free Lift Mast with 2 Free Lift Cylinders.

* Standard



Load Capacity

25BH-9

30BH-9

35BH-9

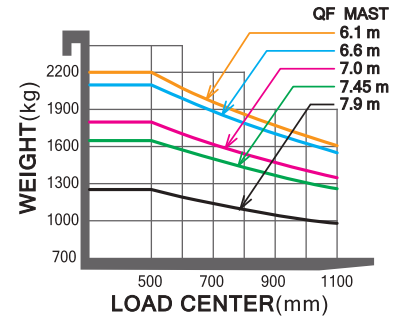
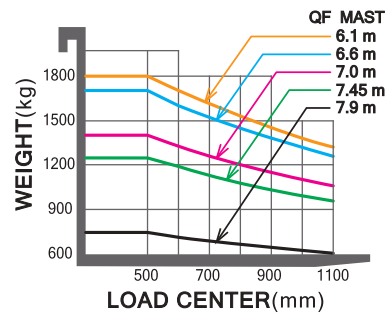
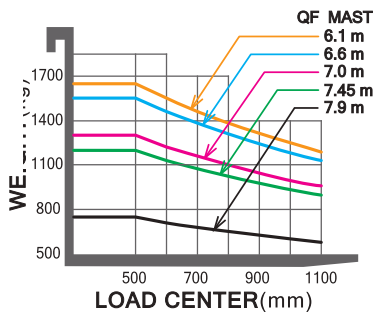
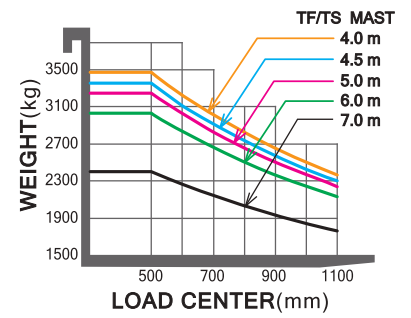
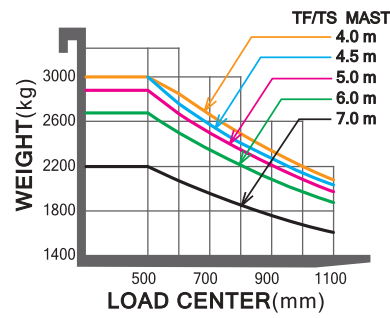
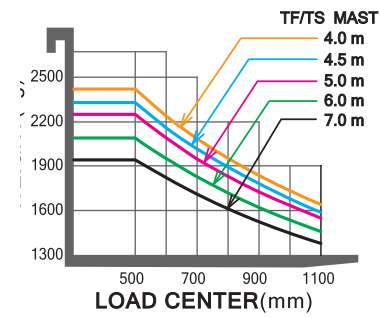
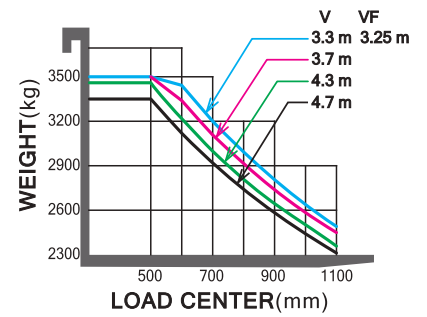
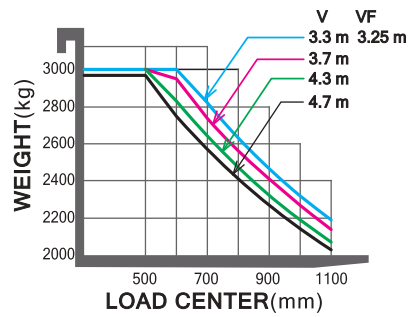
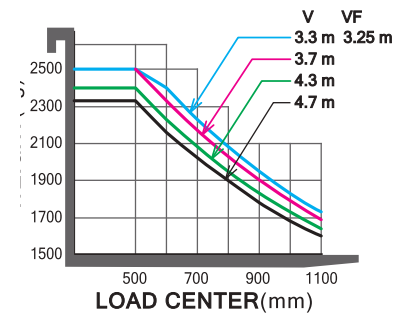

New 9 Series

Various Attachments

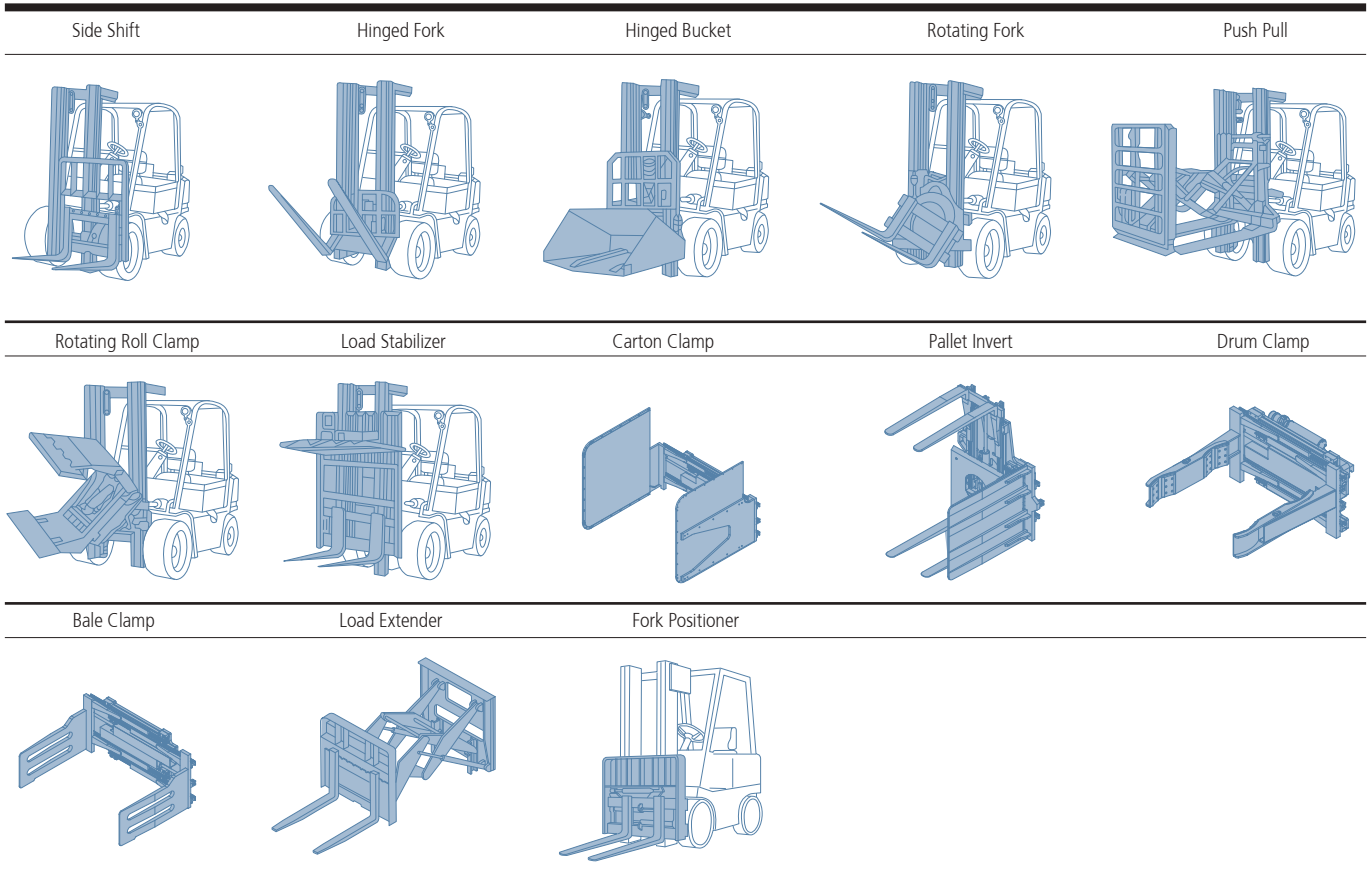

Optional Items

- Fork(mm)
25BH-9 : 900, 1000, 1050(STD), 1200, 1350, 1500, 1650, 1800
30/35BH-9 : 900, 1050(STD), 1150, 1200, 1650, 1800, 1970, 2120, 2300, 2400
- Integral Sideshift, Fork positioner, Integral Fork positioner with shift
- Tire : Solid(STD)/ Pneumatic / Non-marking
Wide tire[25/30BH-9 : Front tire (23x10-12)]
- Seat : Heat
- Finger Tip Control
- Cold Storage (for -30° cold working environments)
- M.C.V : 2-Spool, 3-Spool (STD), 4-Spool

- Auto Fork Leveling
- Beacon Lamp
- Rear Work Lamp
- UL : ES, EE
- Cabin with heater
- Direction Switch on Lever



Dimension

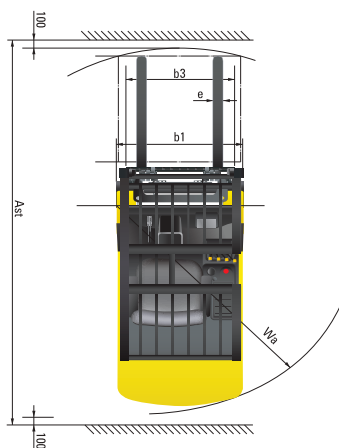
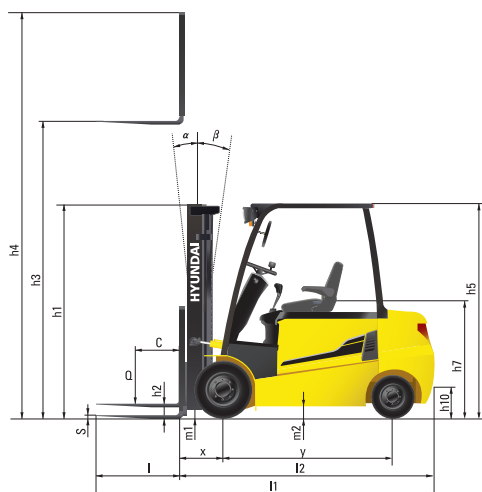

Specification

Identification				
1.1	Manufacturer		Hyundai	
1.2	Manufacturer's type designation		25BH-9	30BH-9 35BH-9
1.3	Drive : electric(battery or mains) ,diesel, petrol ,fuel gas, manual		electric	electric
1.4	Type of operation : hand, pedestrian, standing, seated, order - picker		seated	seated
1.5	Load capacity	lb/kg	5,500 / 2,500	6,600 / 3,000 7,700 / 3,500
1.6	Load center distance	c in/mm	24 / 500	24 / 500
1.8	Load distance, center of drive axle to fork	x in/mm	18.0 / 458	18.0 / 458
1.9	Wheelbase	y in/mm	62.0 / 1,575	67.7 / 1,719
Weights				
2.1	Truck weight	lb/kg	10,384 / 4,710	11,310 / 5,130 12,357 / 5,605
2.2	Axle Loading, Loaded Front - Rear	lb/kg	13,977 - 1,918 / 6,340 - 870	15,955 - 1,969 / 7,237 - 893 17,756 - 2,317 / 8,054 - 1,051
2.3	Axle Loading, Unloaded Front - Rear	lb/kg	5,115 - 5,269 / 2,320 - 2,390	5,655 - 5,655 / 2,565 - 2,565 5,686 - 6,671 / 2,579 - 3,026
Wheels, Chassis				
3.1	Tires : solid rubber (V), superelastic (SE), pneumatic (P), polyurethane (PE)		SE, P	SE, P SE, P
3.2	Front tire size (O x width)		23X9-10	23X9-10 23X10-12
3.3	Rear tire size (O x width)		18X7-8	18X7-8 18X7-8
3.5	Wheels, number front rear (x = driven wheels)		2x/2	2x/2 2x/2
3.6	Track width (front)	in/mm	39.1 / 993	39.1 / 993 39.6 / 1,005
3.7	Track width (rear)	in/mm	38.6 / 980	38.6 / 980
Dimensions				
4.1	Mast / fork carriage tilt forward / backward	degrees	6/8	6/8 6/8
4.2	Lowered Mast height	h1 in/mm	85.1 / 2,162	85.1 / 2,162 88.3 / 2,243
4.3	Free lift height	h2 in/mm	4.5 / 115	4.5 / 115
4.4	Lift Height	h3 in/mm	130.1 / 3,305	130.1 / 3,305 130.1 / 3,305
4.5	Extended mast height	h4 in/mm	176.6 / 4,485	176.6 / 4,485
4.7	Overhead guard (cab) height	h5 in/mm	87.0 / 2,210	87.0 / 2,210
4.8	Seat height / Standing height	h7 in/mm	44.0 / 1,118	44.0 / 1,118
4.12	Coupling height	h10 in/mm	15.6 / 396	15.6 / 396
4.19	Overall length	l1 in/mm	134.4 / 3,415	139.6 / 3,545 143.7 / 3,650
4.20	Length to face of forks	l2 in/mm	93.1 / 2,365	98.2 / 2,495 102.4 / 2,600
4.21	Overall width	b1 in/mm	47.0 / 1,195	47.0 / 1,195
4.22	Fork dimension (length x width x thickness)	in/mm	41.3 x 3.9 x 1.8 / 1050x100x45	41.3 x 4.8 x 1.8 / 1050x122x45 41.3 x 4.8 x 1.8 / 1050x122x45
4.23	Fork carriage ISO 2328, class / type A, B		II/A	III/A III/A
4.24	Fork - carriage width	b3 in/mm	43.4 / 1,102	43.4 / 1,102
4.31	Minimum ground clearance (mast)	m1 in/mm	4.6 / 117	4.6 / 117 5.0 / 128
4.32	Minimum ground clearance (center of wheelbase)	m2 in/mm	4.6 / 116	4.6 / 116
4.33	Aisle Width For Pallets 1000 x 1200 Crossways (LxW)	Ast in/mm	138.4 / 3,516	144.3 / 3,664 144.7 / 3,676
4.34	Aisle Width Of Pallets 800 x 1200 Crossways (W L)	Ast in/mm	145.4 / 3,694	151.6 / 3,851 152.1 / 3,863
4.35	Minimum turning radius	Wa in/mm	75.8 / 1,925	80.9 / 2,055 84.4 / 2,145
Performance Data				
5.1	Travel speed, loaded/ unloaded (80V)	mph/kph	11.2 - 11.8 / 18.0 - 18.9	11.2 - 11.8 / 18.0 - 18.9
5.2	Lift speed, loaded/ unloaded (80V)	ft/s	1.3 / 2.0	1.1 / 1.6 1.0 / 1.6
		mm/s	410 / 600	340 / 500 300 / 500
5.3	Lowering speed, loaded/unloaded	ft/s	1.6 / 1.5	1.6 / 1.5
		mm/s	500 / 450	500 / 450 500 / 450
5.4	Max. drawbar pull, loaded/ unloaded S2 5min	N	18,022 / 17,767	17,865 / 17,747 16,846 / 16,914
5.5	Max. gradient performance, loaded/ unloaded S2 5min	%	26 / 24	22 / 24 19 / 22
5.6	Service brake		Hydraulic	Hydraulic Hydraulic
E - Motor				
6.1	Drive motor rating S2 60 min	HP / kW	10.7 / 8.0 x2	10.7 / 8.0 x2
6.2	Lift motor rating at S3 20% (S2 10min)	HP / kW	19.7	19.7
6.3	Battery voltage	V	80	80
6.4	Battery weight	lb/kg	3,241 / 1,470	3,924 / 1,780 3,924 / 1,780
6.5	Battery compartment dimensions L x W x H	in/mm	40.5x28.1x31.2 / 714x1030x794	40.5x33.8x31.3 / 858x1030x794 40.5x33.8x31.3 / 858x1030x794
Other Details				
7.1	Type of drive control		AC	AC AC



MONTREAL (Head office)

100A, Hymus Blvd.
Pointe-Claire (Québec) H9R 1E4
Phone: 514 694-4223
Toll free: 1 866 421-4223
info@elevex.ca

SAGUENAY

2305, Alexis-Le-Trotteur Street
Jonquière (Québec) G7X 9H8
Phone : 418 543-0000
Toll free: 1 866 421-4223