

# 15/18/20BCS-9

Stand up Counterbalance Trucks

MOVING YOU FURTHER

HYUNDAI MATERIAL HANDLING



---

# Your satisfaction is **our priority!**

Hyundai introduces a new line of **9-series** battery forklift trucks.

The newly designed stand up counter balanced trucks provide every operator with comfortable driving, increased productivity and easy maintenance.



■ Some of the photos may include optional equipment.

### Compact forklift with proven AC technology

- Maximum performance
- Comfortable operating room
- Curve control system
- Load weight indicator
- 3.5" LCD smart display monitor with self-diagnostics
- Water proof controller
- EHPS Steering system for higher efficiency
- Ergonomically designed operating system
- Auto tilt leveling (optional)



---

# Superior Power & Optimal Performance

---

## Curve control

Curve Control limits travel speed based on turning radius, reducing speed for a smooth, precise turning operation for the driver.

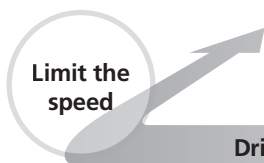

## Minimum Turning Radius

Compact design suitable for narrow aisle operation guarantees work efficiency and maximum space utilization.



■ Some of the photos may include optional equipment.

Smooth running, efficient and ergonomically designed, 15/18/20BCS-9 series are built to meet your needs.

# 15/18/20BCS-9

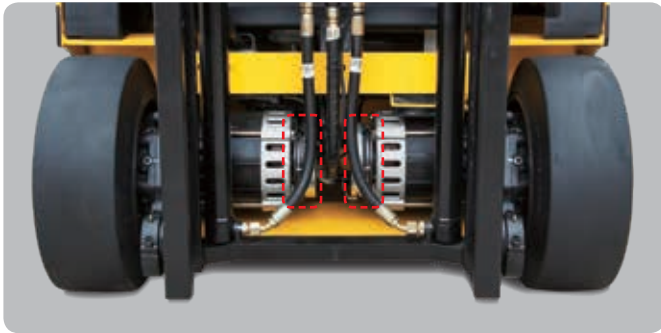

### Dual Drive Motor & Auto Parking System

Powerful and efficient dual drive motor enables superior throughput with faster speed. Electric disc brakes provide emergency stopping and parking for the truck. Parking brake actuated automatically when the pedal released. The pre-adjusted brake assemblies require no maintenance.



### On Demand Steering

Whenever operator use the steering, hydraulic motor is activated it reduce steering noise and energy consumption.



### Energy Efficiency

H(High) mode : 100%  
N(Normal) mode : 110%  
E(Economic) mode : 120%

### High Technology ZAPI Controller

The efficient, almost noiseless, 8kHz(high frequency) controller provides smooth and operation and protection for low & high voltage, overheating and fault recording.



### Drive Motor & Pump Motor

AC motors are designed for optimum reliability and efficiency while providing low noise levels. The AC motors are equipped with temperature sensors to ensure long motor life.



### Excellent Gradeability Operation & Anti Roll Back

A powerful dual drive motor provides for exceptional stability and excellent gradeability. When restarting after stop on a slope, an anti-roll back function ensure operational safety.

	Travel Speed (MAX)	Gradeability (MAX)	
		unloaded	loaded
15BCS-9	12.1 Km/h	15%	15%
18BCS-9	12.1 Km/h	15%	15%
20BCS-9	12.1 Km/h	15%	15%

# Optimised Ergonomics & Advanced Safety



■ Some of the photos may include optional equipment.



## Adjustable Armrest and Large Backrest

Adjustable armrest and large backrest with soft material cushion are applied for operator's safety and comfort.



## Joystick Lever

Minimal operator effort is required for precise, safe and productive control. The lever's contoured design provides comfort operation.

A design based on human engineering relieves fatigue and increases operator's efficiency.

## 15/18/20BCS-9



### New High Visibility for Safe Operation

The operator is able to work with increased safety and accuracy due to a wider mast view.



### Cup Holder, Console Box & Storage Space

Additional storage compartments are located inside the operating space for operator's convenience.



### Strong Overhead Guard

The safety overhead guard meets ISO 6055 and ANSI regulations and protects the operator during hazardous work.



Non Slip Floor Mat



Blue Spot Lamp (optional)



Accessory Switches



12V Power Socket

# Best Convenience & Easy Maintenance

BCS-9 is designed for uptime. All components have been arranged for ease and efficient maintenance.

**Battery Disconnecter**



**Grease Fillings**



**Steering System**



**SBR Sensing Switch**



**Tank for Filter for Easy Replacement**



**Reliable ZAPI AC Controller**



An ideal arrangement of component parts ensures easy access and convenience for maintenance.

# 15/18/20BCS-9

## Advanced LCD Monitor

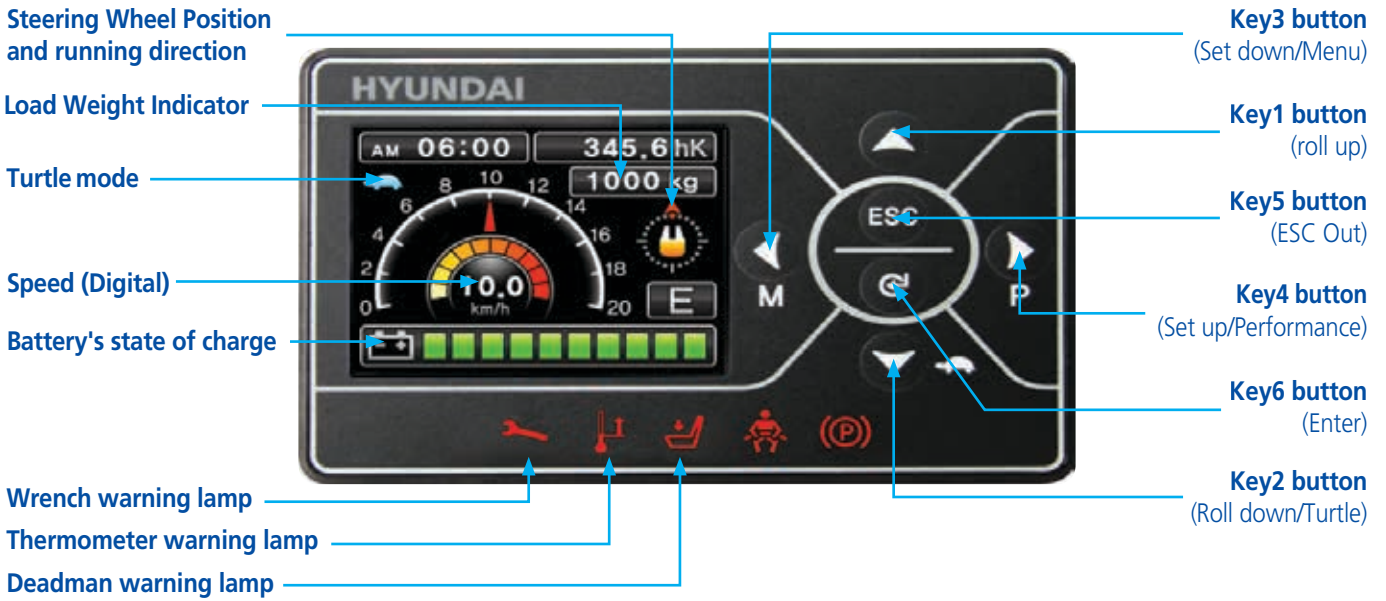

**H** (High) mode **N** (Normal) mode **E** (Economic) mode  
**Turtle mode**

The LCD color monitor with 3.5 inch graphic smart display allows the operator to easily and efficiently control the machine. The monitor provides information about speed & accelerator level, steer angle & travel direction, battery discharge indicator, hour meter & working mode. The optional load indicator displays the load weight and the height of fork in the monitor. System fault is also displayed to keep the forklift in the optimum condition. The operator can select various performance modes to meet all working conditions. It is available multi-languages (maximum 11) for operator is available for global use.



### Easy battery replacement

The battery compartment is equipped with a side battery removal assembly for easy replacement.

# New 9 Series

## Load Capacity

### 15BCS-9

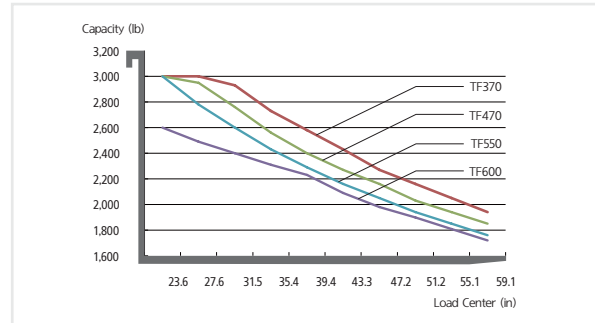
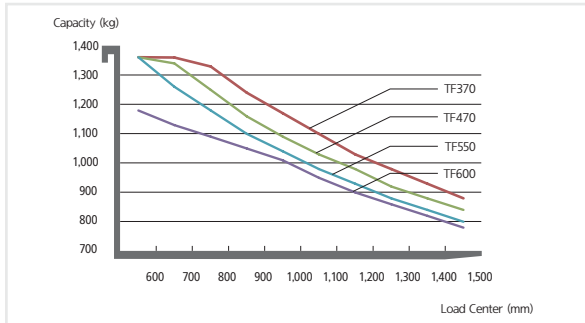

### 18BCS-9

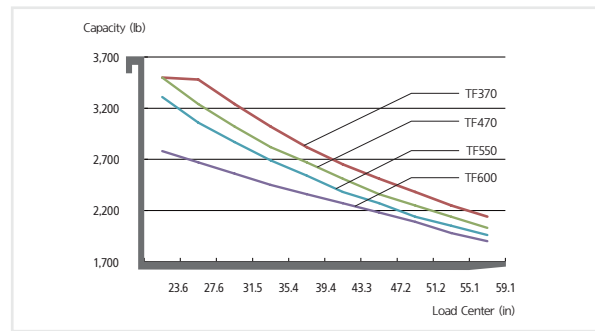
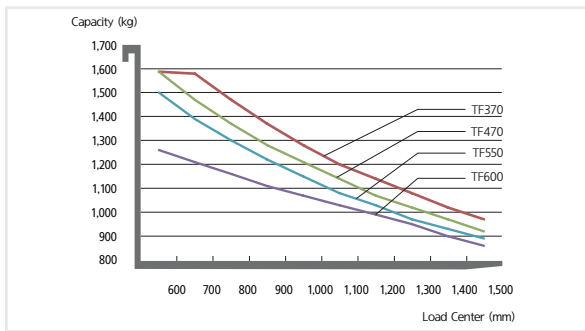

### 20BCS-9

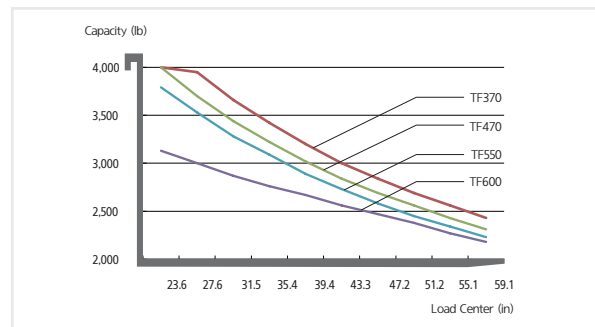
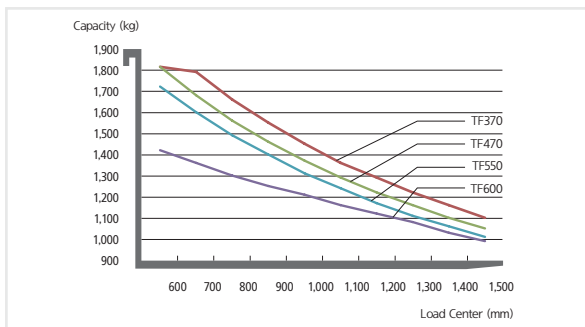

## Optional Items

### Integral Sideshift

- Max. 120mm

### UL "EE" rating

### Beacon Lamp

- Amber, Blue, Red

### Rear Work Lamp

### Fork Length (mm)

- 900, 950, 1000, 1050, 1150, 1350, 1500, 1600

### Fence

- Wire net type (STD)
- Tempered glass type (OPT)

### Tire

- Vulkollan

### Cold Storage (for -30° cold working environments)

### Battery

- 700AH (15/18BCS-9), 800AH(20BCS-9)

### 3 Phase Charger

- 220/380V, 410V, 440V

### LED work lamp

### Blue spot

## Mast Specification (15BCS-9)

Mast Type		Maximum Fork Height		Overall Height (Lowered)		Free Lift Height				Tilt Angle		Load Capacity without side shift		Load Capacity with side shift		Truck Weight (Unloaded)	
						With Load Backrest		Without Load Backrest		Fwd	Bwd	24 in LC	600mm LC	24 in LC	600mm LC		
		in	mm	in	mm	in	mm	in	mm	deg	deg	lb	kg	lb	kg	lb	kg
3-Stage Full Free Lift	TF370	147.2	3740	68.8	1748	20.9	531	48.9	1243	5	5	3000	1360	3000	1360	8366	3795
	TF400	159.1	4040	72.8	1848	24.8	631	52.9	1343	5	5	3000	1360	3000	1360	8408	3814
	TF430	170.9	4340	76.7	1948	28.8	731	56.8	1443	5	5	3000	1360	3000	1360	8450	3833
	TF450	178.7	4540	80.6	2048	32.7	831	60.7	1543	5	5	3000	1360	3000	1360	8492	3852
	* TF470	186.6	4740	82.6	2098	34.7	881	62.7	1593	5	5	3000	1360	3000	1360	8514	3862
	TF500	198.4	5040	86.5	2198	38.6	981	66.7	1693	5	5	3000	1360	2930	1330	8556	3881
	TF550	218.1	5540	94.4	2398	46.5	1181	74.5	1893	5	5	3000	1360	2820	1280	8640	3919
TF600	237.8	6040	102.3	2598	54.4	1381	82.4	2093	5	5	2600	1180	2420	1100	8774	3980	

## Mast Specification (18BCS-9)

Mast Type		Maximum Fork Height		Overall Height (Lowered)		Free Lift Height				Tilt Angle		Load Capacity without side shift		Load Capacity with side shift		Truck Weight (Unloaded)	
						With Load Backrest		Without Load Backrest		Fwd	Bwd	24 in LC	600mm LC	24 in LC	600mm LC		
		in	mm	in	mm	in	mm	in	mm	deg	deg	lb	kg	lb	kg	lb	kg
3-Stage Full Free Lift	TF370	147.2	3740	68.8	1748	20.9	531	48.9	1243	5	5	3500	1590	3500	1590	8774	3980
	TF400	159.1	4040	72.8	1848	24.8	631	52.9	1343	5	5	3500	1590	3480	1580	8816	3999
	TF430	170.9	4340	76.7	1948	28.8	731	56.8	1443	5	5	3500	1590	3410	1550	8858	4018
	TF450	178.7	4540	80.6	2048	32.7	831	60.7	1543	5	5	3500	1590	3350	1520	8900	4037
	* TF470	186.6	4740	82.6	2098	34.7	881	62.7	1593	5	5	3500	1590	3300	1500	8922	4047
	TF500	198.4	5040	86.5	2198	38.6	981	66.7	1693	5	5	3440	1560	3240	1470	8964	4066
	TF550	218.1	5540	94.4	2398	46.5	1181	74.5	1893	5	5	3300	1500	3130	1420	9048	4104
TF600	237.8	6040	102.3	2598	54.4	1381	82.4	2093	5	5	2770	1260	2770	1180	9182	4165	

## Mast Specification (20BCS-9)

Mast Type		Maximum Fork Height		Overall Height (Lowered)		Free Lift Height				Tilt Angle		Load Capacity without side shift		Load Capacity with side shift		Truck Weight (Unloaded)	
						With Load Backrest		Without Load Backrest		Fwd	Bwd	24 in LC	600mm LC	24 in LC	600mm LC		
		in	mm	in	mm	in	mm	in	mm	deg	deg	lb	kg	lb	kg	lb	kg
3-Stage Full Free Lift	TF370	147.2	3740	68.8	1748	20.9	531	48.9	1243	5	5	4000	1810	4000	1810	9136	4144
	TF400	159.1	4040	72.8	1848	24.8	631	52.9	1343	5	5	4000	1810	3960	1800	9178	4163
	TF430	170.9	4340	76.7	1948	28.8	731	56.8	1443	5	5	4000	1810	3880	1770	9220	4182
	TF450	178.7	4540	80.6	2048	32.7	831	60.7	1543	5	5	4000	1810	3830	1740	9261	4201
	* TF470	186.6	4740	82.6	2098	34.7	881	62.7	1593	5	5	4000	1810	3790	1720	9284	4211
	TF500	198.4	5040	86.5	2198	38.6	981	66.7	1693	5	5	3920	1780	3725	1690	9325	4230
	TF550	218.1	5540	94.4	2398	46.5	1181	74.5	1893	5	5	3790	1720	3590	1630	9409	4268
TF600	237.8	6040	102.3	2598	54.4	1381	82.4	2093	5	5	3130	1420	2950	1340	9544	4329	

# Technical Data for 15/18/20BCS-9

## Identification

1.1	MANUFACTURER (ABBREVIATION)	HYUNDAI	HYUNDAI	HYUNDAI	
1.2	MANUFACTURER'S TYPE DESIGNATION	15BCS-9	18BCS-9	20BCS-9	
1.3	DRIVE : ELECTRIC (BATTERY OR MAINS), DIESEL, PETROL, FUEL GAS	electric	electric	electric	
1.4	TYPE OF OPERATION: HAND, PEDESTRIAN, STANDING, SEATED, ORDER-PICKER	standing	standing	standing	
1.5	LOAD CAPACITY / RATED LOAD	kg(lb)	1,360(3,000)	1,590(3,500)	1,810(4,000)
1.6	LOAD CENTER DISTANCE	c mm(in)	600(24)	600(24)	600(24)
1.8	LOAD DISTANCE, CENTER OF DRIVE AXLE TO FORK	x mm(in)	330(12.9)	330(12.9)	330(12.9)
1.9	WHEELBASE	y mm(in)	1,152(45.3)	1,152(45.3)	1,222(48.1)

## Weights

2.1	SERVICE WEIGHT	kg(lb)	3,862(8,514)	4,047(8,922)	4,211(9,283)
2.2	AXLE LOADING, LOADED FRONT/REAR	kg(lb)	4,442(7,780) (9,792/1,719)	4,872(7,765) (10,740/1,686)	5,256(7,765) (11,587/1,686)
2.3	AXLE LOADING, UNLOADED FRONT/REAR	kg(lb)	1,987/1,875 (4,380/4,133)	2,001/2,046 (4,411/4,511)	2,066/2,145 (4,554/4,729)

## Wheels, Chassis

3.1	TIRES : SOLID RUBBER, SUPERELASTIC, PNEUMATIC, POLYURETHANE	V, PE	V, PE	V, PE	
3.2	TIRE SIZE, FRONT	18x7x12.12	18x7x12.12	18x7x12.12	
3.3	TIRE SIZE, REAR	10x5x6.5	10x5x6.5	10x5x6.5	
3.5	WHEELS, NUMBER FRONT / REAR (X = DRIVEN WHEELS)	2x/1Dual	2x/1Dual	2x/1Dual	
3.6	TREAD, FRONT	mm(in)	889(35)	889(35)	889(35)
3.7	TREAD, REAR	mm(in)	181(7.12)	181(7.12)	181(7.12)

## Basic Dimensions

4.1	TILT OF MAST/FORK CARRIAGE FORWARD/BACKWARD	$\alpha/\beta$ degrees	5/5	5/5	5/5
4.2	HEIGHT, MAST LOWERED	h1 mm(in)	2,098(82.6)	2,098(82.6)	2,098(82.6)
4.3	FREE LIFT	h2 mm(in)	881(34.7)	881(34.7)	881(34.7)
4.4	LIFT HEIGHT	h3 mm(in)	4,740(186.6)	4,740(186.6)	4,740(186.6)
4.5	HEIGHT, MAST EXTENDED	h4 mm(in)	5,957(234.5)	5,957(234.5)	5,957(234.5)
4.7	HEIGHT OF OVERHEAD GUARD (CABIN)	h5 mm(in)	2,235(87.9)	2,235(87.9)	2,235(87.9)
4.8	SEAT HEIGHT / STAND HEIGHT REL. TO SIP	h7 mm(in)	200(7.8)	200(7.8)	200(7.8)
4.19	OVERALL LENGTH	l1 mm(in)	2,777(109.3)	2,777(109.3)	2,847(112.0)
4.20	LENGTH TO FACE OF FORKS	l2 mm(in)	1,727(67.99)	1,727(67.99)	1,797(70.7)
4.21	OVERALL WIDTH	b1 mm(in)	1,067(42.0)	1,067(42.0)	1,067(42.0)
4.22	FORK DIMENSIONS	l/e/s mm(in)	40x100x1,050 (1.6x3.9x41.3)	40x100x1,050 (1.6x3.9x41.3)	40x100x1,050 (1.6x3.9x41.3)
4.23	FORK CARRIAGE ITA CLASS	II	II	II	
4.24	FORK-CARRIAGE WIDTH	b3 mm(in)	950(37.4)	950(37.4)	950(37.4)
4.31	GROUND CLEARANCE, BELOW MAST, LOADED	m1 mm(in)	63(2.4)	63(2.4)	63(2.4)
4.32	GROUND CLEARANCE, CENTER OF WHEELBASE	m2 mm(in)	100(3.9)	100(3.9)	100(3.9)
4.33	aisle width for pallets 1000 X 1200 CROSSWAYS (L X W)	Ast mm(in)	3,056(120.3)	3,056(120.3)	3,126(123.0)
4.34	aisle width of pallets 800 X 1200 CROSSWAYS (W X L)	Ast mm(in)	3,178(125.1)	3,178(125.1)	3,248(127.8)
4.35	TURNING RADIUS	Wa mm(in)	1,397(55)	1,397(55)	1,467(57.7)

## Performance Data

5.1	TRAVEL SPEED, LOADED / UNLOADED	km/h(mph)	12.1(7.5)	12.1(7.5)	12.1(7.5)
5.2	LIFT SPEED, LOADED / UNLOADED	ft/min	70.9 / 110.2	66.9 / 110.2	65.0 / 110.2
5.3	LOWERING SPEED, LOADED / UNLOADED	ft/min	94.4 / 84.6	94.4 / 84.6	94.4 / 84.6
5.6	MAX. DRAWBAR PULL, LOADED	N(lb)	12,748(2,866)	12,748(2,866)	12,748(2,866)
5.8	MAX. GRADEABILITY, LOADED	%	15	15	15
5.10	SERVICE BRAKE		Electric release	Electric release	Electric release

## Motor

6.1	DRIVE MOTOR RATING S2 60 MIN	kW(hp)	4.3(5.7)	4.3(5.7)	4.3(5.7)
6.2	LIFT MOTOR RATING AT S3 15%	kW(hp)	14(18.8)	14(18.8)	14(18.8)
6.3	BATTERY ACC. TO DIN 43531/35/36 A, B, C, NO		Lead-Acid	Lead-Acid	Lead-Acid
6.4	BATTERY VOLTAGE	V	36/48	36/48	36/48
6.5	BATTERY WEIGHT	kg(lb)	1,034(2,279.6)	1,034(2,279.6)	1,176(2,592.6)
6.7	BATTERY COMPARTMENT DIMENSIONS LWWH	mm(in)	975/456/800 (38.4/18/31.5)	975/456/800 (38.4/18/31.5)	975/526/800 (38.4/20.7/31.5)

## Other Details

8.1	TYPE OF DRIVE CONTROL		AC	AC	AC
8.2	OPERATING PRESSURE, SYSTEM / ATTACHMENTS	psi	2,465/2,030	2,465/2,030	2,465/2,030
8.3	OIL VOLUME FOR ATTACHMENTS	ℓ/min(GPM-US)	20(5.28)	20(5.28)	20(5.28)
8.4	SOUND LEVEL AT THE DRIVER'S EAR ACCORDING TO DIN 12053	dB (A)	70	70	70
8.5	HEIGHT OF BATTERY ROLLER	R mm(in)	183(7)	183(7)	183(7)

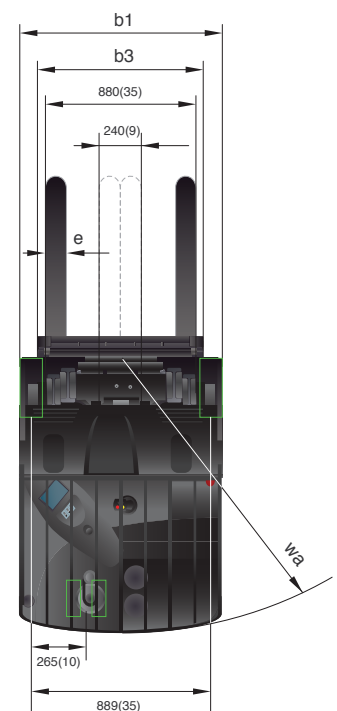
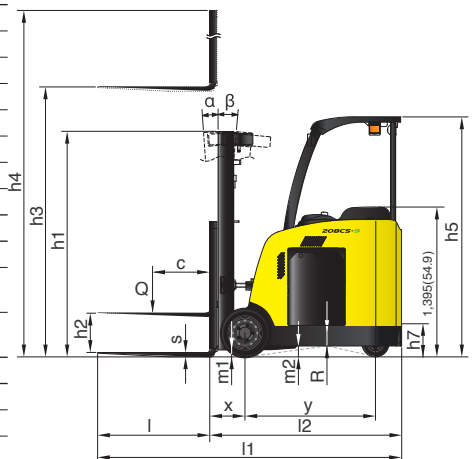

■ The Specifications in this brochure are subject to change for option.

■ The options in this brochure are subject to change to improve the performance of the forklift.

**HYUNDAI**  
**MATERIAL HANDLING**  
 North American Headquarters  
 6100 Atlantic Blvd, Norcross, GA 30071  
 TEL (678) 823 7777 FAX (687) 823 7778

PLEASE CONTACT