

Linde Material Handling

Linde

Experience the innovation.
Linde 346 series electric trucks.

E18, E20, and E20C/P

Capacity 3,500 to 4,000 lb.





Linde technology:

The new 346 series raises the standards for comfort, efficiency, economy of operation, and durability. It is what customers have come to expect from our products.



Linde innovation:
Exceptional design—any way you look at it.

Some pictures may show optional equipment.



The heart of the matter. Introducing the new Linde drive axle.

The new Linde drive axle—an assembly that includes drive motors, hydraulic motor, reduction gears, brake system, and power modules. With this system, Linde engineers have eliminated long power cables, one of the major reasons for excessive energy consumption.

Energy management. New axle design.

It all starts with this new axle design. Linde engineers have once again raised the limits of applied know-how. A technological work of art, it is powerful, completely sealed, and without a doubt the most energy efficient system on the market, all AC technology of course.

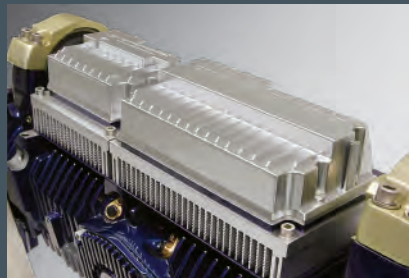

Energy made visible. Performance depends on energy efficiency.

The new Linde electric trucks have a unique energy management system, including an advanced new battery state of charge indicator. In order to accurately display the energy available at any given time, it measures the current and available voltage to provide a continuous update of the batteries overall condition.



Ergonomics. More energy through motivation.

Only a healthy employee is a motivated employee. Operating a forklift for long periods of time is hard work. This is the reason why Linde engineers painstakingly develop the truck around the operator. All areas where man and machine interface are carefully and deliberately designed, from intuitive controls through low noise and vibration levels to excellent visibility. The operator's well being depends on it.



Built-in comfort. The operator always comes first.

- Uncluttered foot-room
- Clear view mast
- Padded adjustable armrest
- Short, hydraulic control levers
- Spring assisted battery cover
- Adjustable steering column



Chassis variation E20 C/P. 4-Wheel configuration.

Linde Combi Axle - Patented technology at your service.

- High pivot point — added stability
- Patented mechanism — smallest turning radius possible
- High mounted cylinders — protected; less damage
- Neoprene mounting — shock absorption

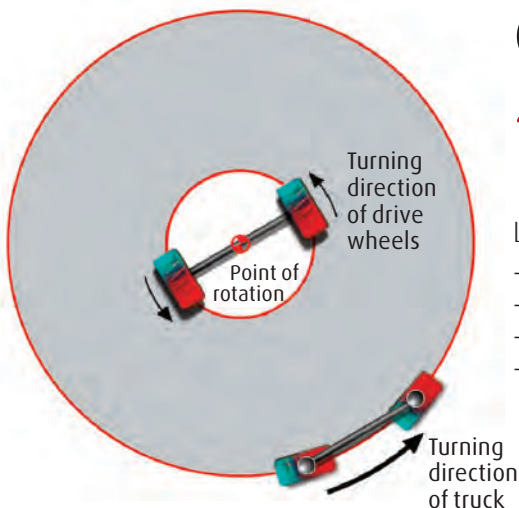



Experience the innovation. Standard means more with Linde.

Standard equipment (chassis, mast, tires) includes:

- Low level, side battery discharge
- Electronically controlled hydraulic valves
- Adjustable padded armrest
- Tow pin and tie down cutout
- Tilt-away armrest
- Two headlights
- Emergency power cut-off
- Adjustable tilt steering column
- AC technology



Adaptable. Professionally designed, functional options.

Linde recognizes the many unique working environments and applications a forklift must be able to handle. In order to provide a truck with optimal productivity our engineers have designed a variety of optional equipment.

Optional equipment:

- UL "EE" rating
- Cold storage package
- Quad masts
- Drive-in rack overhead guard (OHG)
- SE tires
- Battery slides or rollers
- Bottler's tilt
- Light bar



Inside the power unit.

Applied know-how to lower maintenance cost and effort.

- 1000 hours truck maintenance intervals
- Maintenance-free multi-disc brakes
- All components thermal protected
- On-board diagnostics

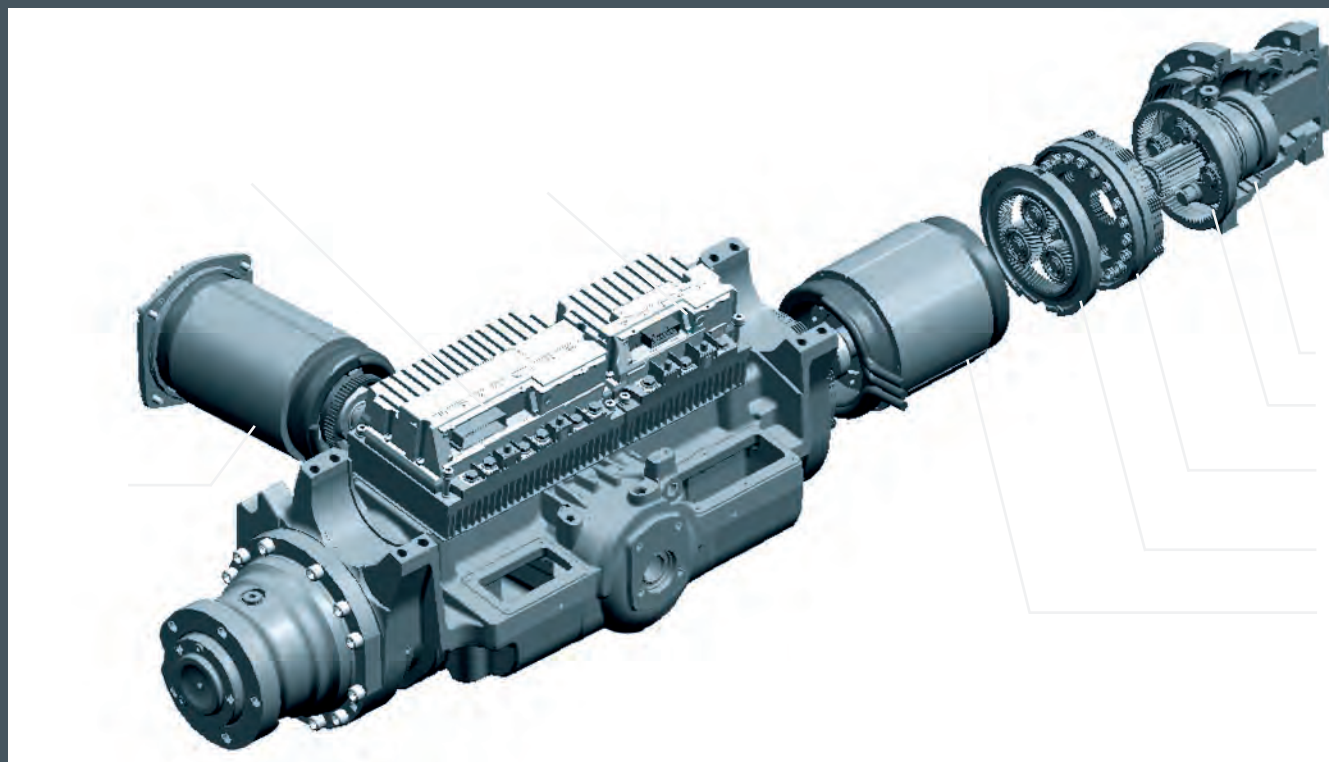

Wheel bearing
Planetary gears
Maintenance-free oil bath disc brake
Planetary gears
DC motor (right)

Service.

Linde quality in technology and service.

Apart from aesthetic appeal and unique technical features, Linde forklifts are built for durability. In tough everyday applications, their reliability and durability is renowned. It's not unusual for Linde forklifts to log 20,000 operating hours and beyond during their lifetime, saving their owners money every single hour.

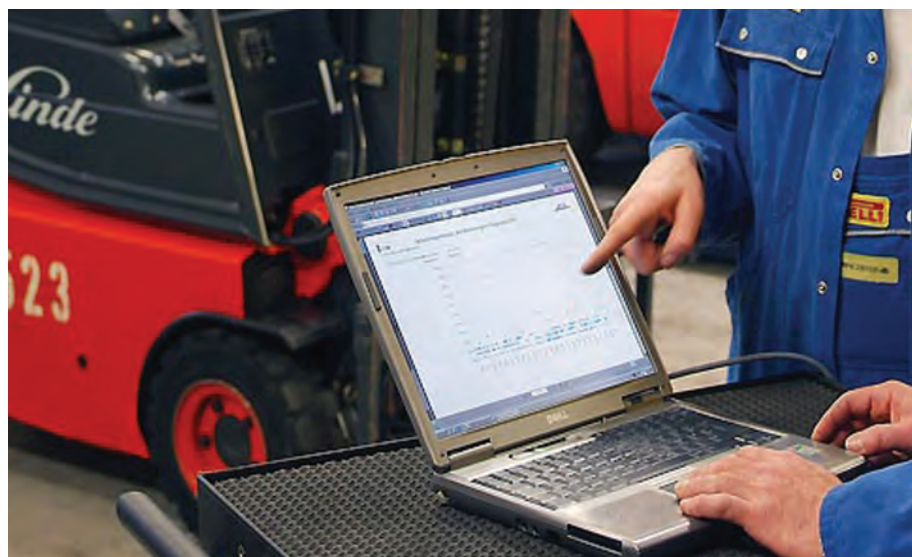



Linde ranks among the world's leading material handling equipment manufacturers. This position has been justly earned. Linde trucks excel not only with their recognized innovative technology, but especially for their low energy and operating costs.

High quality in production is matched by the standard of the service we provide. With our ten manufacturing plants and a comprehensive network of local sales partners, we are at your call around the clock and around the world.

Your local Linde dealer offers you a complete single-source package including qualified pre-sales consulting, after-sales service and flexible finance options—whether leasing, renting, or purchasing.

Linde Material Handling North America Corporation
2450 West 5th North Street, Summerville, SC 29483
Phone: 843.875.8000 • Truck Sales Fax: 843.875.8471
E-mail: trucksales@lmh-na.com • www.lmh-na.com

