

Pushing Limits: The new generation of R14 – R20 reach trucks

Linde Material Handling

Linde







Pushing limits

The new generation of reach trucks from Linde is raising the limits in its class – and in more ways than one: The new trucks not only boast unbeatable user-friendly benefits, they are also exceptionally robust and superbly versatile.

Linde is once again setting the benchmark for outstanding ergonomics, safety and high productivity with excellent cost-efficiency ratios.



R14, R16

The R14 – R 20 is an extremely versatile truck, designed for the widest possible range of applications: Offering bespoke, cost-effective, and highly productive narrow aisle storage solutions.



R14N, R16N, R20N

The narrow version with a chassis width of 1140 mm: For special applications e.g.: drive-in or block storage.

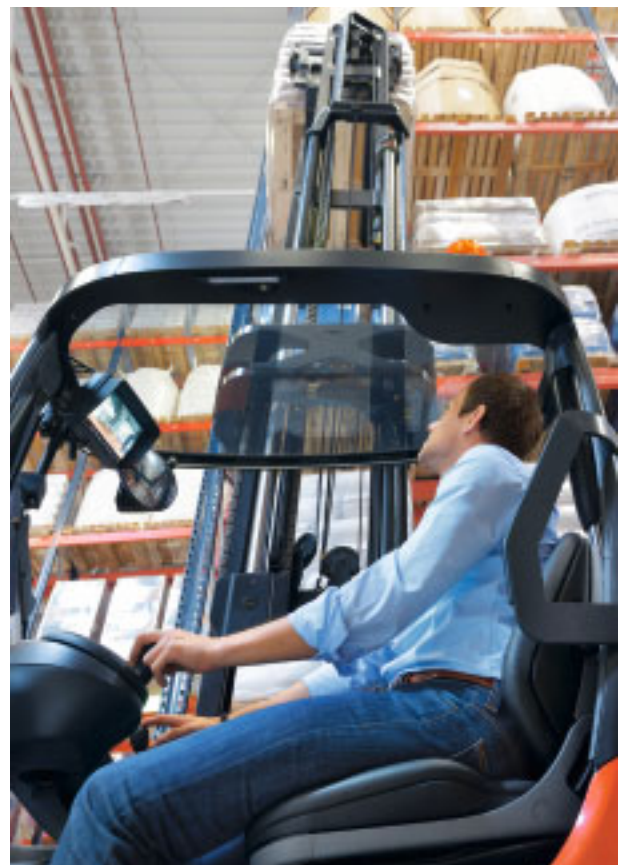

R14HD, R16HD, R20, R20HD

Models with the new torsion resistant Heavy Duty mast: Unrivalled residual capacities up to maximum lift.

Fully equipped as standard: The new Linde reach truck range

Making the best even better by pushing the ergonomic and performance limits – these were our objectives when developing the superb new reach truck range. Every model in the range is equipped with a host of advanced performance and ergonomic features, which come as standard.



Performance

Clear-view torsion resistant fixed masts with integrated side shift and tilting carriage • Rapid lift, lower and reach speeds. Lift height display above the free lift • Induction-hardened reach channels • Effortless electric steering. Powerful maintenance-free, AC traction, lift and steering motors • Four independent braking systems. Automatic speed control when cornering • Comprehensive digital instrument display

Ergonomics

Revolutionary suspended Ergo-Space operator's workstation • Rheological electric steering with variable torque feedback • Linde twin accelerator pedals • Integrated, adjustable control console • Air suspension seat, which automatically adjusts to operator's weight. Seat has height, rake, lateral and lumbar adjustments • Digital instrument display • Dual axis, joystick control • Low, non-slip access step • Various storage pockets for documents and personal items

Safety

Cushioned mast stop at maximum lift • Precision, Linde Load Control • Automatic parking and holding brake functions • Four independent braking systems • Load wheel brakes as standard • Cushioned reach travel stops • Seat interlock switch • Dual, safety related electrical circuits • Battery lock interlock





User-friendliness

Like every Linde truck, the R14-R20 is designed so that its impressive potential can be fully utilised with minimal effort. It is with good reason, that Linde Material Handling products are globally acknowledged as setting the benchmark for **user-friendly operator comfort**. The truck design ensures every operator is able to work **safely** and efficiently without stress or fatigue.



Unsurpassed levels of operator comfort

The new generation of Linde reach trucks is setting new standards in the marketplace thanks to the outstanding levels of comfort and convenience it offers: The operating console can be individually adjusted to suit every operator. Thanks to the various ergonomically located storage pockets, the operator always has work documents and personal items readily to hand – including mobile phones with the optional, integrated auxiliary socket.

Working with the new reach truck the operator experiences unsurpassed levels of stability, comfort, performance and safety. Among the many reasons for this unique driving experience is the responsive rheological electric steering system. The steering torque and number of steering turns lock to lock are individually adjustable to suit every operator's preferences. The renowned precision Linde Load Control of the mast functions and the combination of 180° steering and twin accelerator pedals provide effortless operation. The operator's left foot is always safely within the chassis contours. The Linde twin pedal system is very intuitive: Left foot for forward travel, right foot for reverse travel. Automatic regenerative braking occurs as accelerator pedal is released.



Responsive and precise finger-tip, joystick control of the mast functions



With the Linde rheological electric steering, incorporating adjustable torque feedback and number of turns lock to lock. The new range offers the perfect narrow aisle handling solution



Linde twin accelerator pedal format – seamless reversing without switching feet

Four specially designed resilient mountings that isolate the operator's workstation from the base chassis to eliminate unwelcome floor vibrations



Workstation Suspension: Designed to minimise whole body vibrations

The operator's daily work is often negatively influenced by uneven surfaces, crossing thresholds or floor expansion joints, which transmit vibrations to the body. To absorb and minimise these vibrations, the workstation of the new reach truck is uniquely suspended and isolated from the base chassis via four specially designed resilient mountings.

In addition, the newly developed and revolutionary air suspension comfort seat from Linde also absorbs these vibrations before they affect the operator, and the seat's air suspension system automatically adjusts to the operator's weight within an 80mm air suspension band. Every operator can select a bespoke and superbly comfortable working posture. These important innovations ensure that whole body vibrations are minimised.



The air suspension seat automatically adjusts the air suspension settings to suit the individual operator's weight

Personalised ergonomic settings

The individual adjustment options for the air suspension comfort seat include height, rake, lateral movement and lumbar support. The seat automatically adjusts suspension to the operator's weight and together with the adjustable, integrated control console and the electric steering with variable torque, enables every operator to select their preferred working posture.

The spacious workstation, comfort seat and intuitive location of all the operating controls, which include the finger-tip control joysticks, digital instrument display, compact steering wheel and the adjustable, integrated control console, gives the operator assured and total control at all times. The operator is able to work with optimum efficiency and comfort through the entire shift, without fatigue.



Matières plastiques

Matières plastiques
Plásticos
Materie plastiche

Kunststoffe
Plastics
Matières plastiques
Plásticos

6 729 777 623

Safety takes priority

Naturally, safety was the number one consideration in the functional specification when developing the new Linde reach truck. For example, the panoramic High Vision armoured glass roof option, gives the operator totally unobstructed upward visibility when storing and retrieving loads at height. This is a significant contribution to safety in narrow aisle storage applications. In particularly confined spaces or for larger operator's, the optional shoulder guard offers additional safety.

The Linde BlueSpot™ with its LED technology warns pedestrians and other mobile operators of an approaching truck in good time, thereby considerably reducing the risk of accidents, particularly when exiting warehouse aisles and at junctions where visibility may be restricted. The highly efficient all-wheel-braking system, which is fitted as standard, ensures effective braking performance in all situations.

The unique Linde automatic holding brake function secures and stabilises the truck when storing and retrieving loads or when negotiating gradients.



The Linde BlueSpot™ with its LED technology for maximum safety

BlueSpot LED technology





Robustness

Linde trucks are designed with one objective: To give our customers highly productive and cost effective materials handling solutions. This is achieved by producing **first class products** incorporating advanced technology, with **unsurpassed levels** of reliability and durability. It requires exceptional quality in the truck design and its components, as well as modern manufacturing processes and highly skilled production personnel.

Efficiency is not the only benefit

Reliability and longevity are qualities for which our brand is renowned. To ensure leading edge technology for the new generation of Linde reach trucks in the long term, individual truck components are carefully selected and undergo intensive testing during and after the development phase.

High workload capability

The individual truck components are thoroughly tested according to stringent Linde quality standards. Components that are subject to particularly heavy usage on a daily basis undergo several specific testing procedures and are designed using advanced techniques. This allows Linde to guarantee maximum structural integrity, extreme robustness and a durable reliability for components subjected to heavy use, such as the induction-hardened reach leg channels, the chassis and the mast.

Maintenance and servicing

New standards have also been set for maintenance and ease of servicing of the new generation of reach trucks. Everything is quicker and easier. The battery can be replaced either vertically or from the side. The maintenance-free AC motors for steering, traction and lift are sealed against the ingress of dust and moisture. The adjustable controller has a detailed diagnostic process, and all key components are easily accessible for servicing. The operator's seat can be raised effortlessly and swivelled away for easy access to the motors and other key components. A CAN bus interface (for diagnostics and bespoke performance parameters) is easily accessed via a computer port under the console and the hydraulic oil dipstick is within easy reach for routine checks.



Durability due to especially induction-hardened reach channels



Swivel-mounted operators seat for ease of service access







Performance

The name Linde Material Handling is synonymous with highly functional **innovations** and advanced technology. It has also always stood for tenacious determination in creating significant and tangible added value with its high quality, **high-performance** and very cost-efficient trucks. This added value is the basis for our technological advantage, and also explains why the handling performance and productivity of our trucks sets the benchmark for the whole industry.



The new benchmark in load handling

Torsional mast movements and dynamic oscillations have been minimised thanks to the enhanced mast stability – even when handling heavy loads at maximum height, the triplex fixed mast remains stable. Loads are positioned by the integrated side shift and tilting fork carriage.

This allows residual load capacities to be increased while also improving load safety. Moreover, the inherent mast stability with minimal oscillation saves time, which results in higher productivity with faster, safer load handling.

The combination of the Linde twin accelerator pedal layout, Linde Load Control and 180° electric steering ensures seamless and precise manoeuvring when storing and retrieving loads, leading to significant efficiency savings and ensuring cost-effective utilisation of the trucks.

The 180° steering optimises the turning radius at all times. This is because the drive wheel is always positioned exactly 90° from the drive direction. An increase in handling performance is practically guaranteed in the new trucks with the combination of a small turning radius and a seamless direction change system.



While tilting the fork carriage forwards or backwards the fixed mast remains stable.

Up to 20% greater load capacity

Comparison of values with previous generation:

Lifting speed with load	improved by up to 41%
Lifting speed without load	improved by up to 27%
Lowering speed without load	improved up to 22%
Residual load capacity	improved by up to 20%
Productivity	improved by up to 8%
Energy consumption	improved by up to 8%

The battery capacity range has also been increased up to 930 Ah.

The TÜV (Technical Inspection Authority) warehouse technology performance test for reach forklift trucks confirms the high level of performance and underlines the pioneering role of the new generation of Linde reach trucks.

Time required

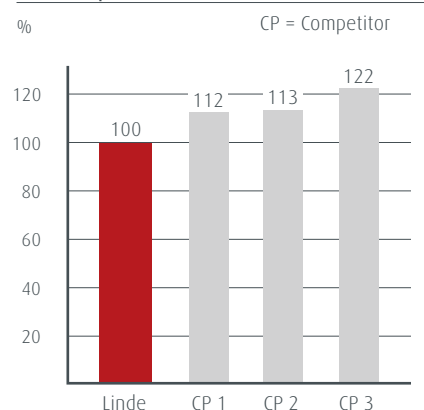

With the choice of three different performance settings available, the perfect balance between performance and energy consumption ratios can be achieved depending on the application. This superb versatility means that if the highest Performance mode is not required for specific tasks or periods, but the many other benefits of the new reach truck are still needed, the performance setting can be switched to either Efficiency or Economy mode to achieve optimum cost and efficiency performance ratios. With this perfect balance between performance, energy consumption and environmental awareness, the Linde reach trucks remain the most efficient in their class in all three modes.

Performance mode

Pure power at maximum speed: This mode ensures the highest level of effectiveness and fully utilises all of its performance benefits.

Efficiency mode

Efficiency mode is exactly half way between performance and economy modes in terms of performance. Therefore, if energy costs are a factor but performance should not be significantly reduced, Efficiency mode should be selected.

Economy mode

The maximum power output may not be needed for every task in the application so energy consumption and costs can be reduced at the touch of a button by selecting Economy mode. For example: in high volumes of operational traffic, when using the truck in narrow aisles or when handling particularly fragile loads, selecting Economy mode reduces the risk of accidents and damage during operation as well as saving energy.





Versatility

Linde Material Handling has the most comprehensive and versatile reach truck offering in the market. Within the new range there is a **bespoke handling solution** for virtually every type of narrow aisle application. Numerous customer-specific **purpose-built specifications** are also available for individual application requests.

As individual as your business

Made for your business: Every storage facility places unique requirements on the reach truck. A comprehensive choice of individual features is available depending on the application. These features customise the Linde reach truck to meet your specific requirements. With the right selection of bespoke features, the truck will deliver the business objectives you require from your handling equipment by ensuring both the operator and the truck are working in perfect harmony. The result is maximum utilisation of the equipment and personnel, with the best possible cost and efficiency ratios.



- Standard version
- Drive-in version
- Cold store version, with optional cab
- Weather protection cab
- Version with draught protection door

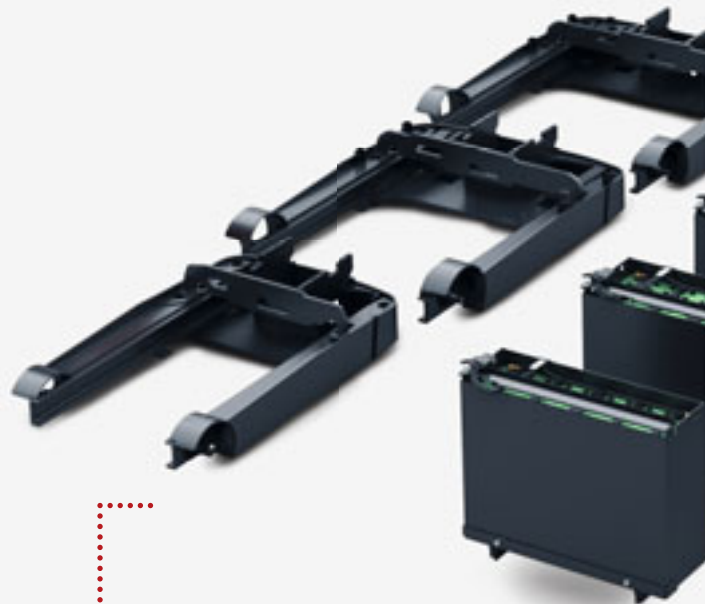

Four different chassis widths depending on application



Over 200 mast options for all lift heights
from 4.40 m to 11.5 m



Five different chassis lengths depending
on the required residual load capacity



Seven different battery sizes (special versions
for standard and narrow chassis) up to 930 Ah

A range of options to match every application

The new generation of Linde reach trucks offers impressive versatility to meet individual business needs courtesy of its numerous innovations and options.



Linde panoramic High Vision armoured glass roof for unrestricted upwards visibility



Vision package for improved visibility with innovative dual cameras mounted on overhead guard and mast



Optional single accelerator pedal version with selector switch on console to change travel direction. Left foot interlock switch





LED working spotlights: bright, modern LED technology for optimum visibility



Linde BlueSpot™: Visual travel path warning unit for increased safety in the warehouse and in areas with restricted visibility



Side shoulder guard for enhanced operator protection in confined spaces



Centring of the fork carriage, horizontal positioning and soft landing for the forks provides smoother, safer load handling at the touch of a button



Linde Material Handling ranks among the world's leading manufacturers. This position has been justly earned. Linde trucks excel not only with their recognized innovative technology but especially their low energy and operating costs, which can be as much as 40% less than competitors.

High quality in production is matched by the standard of the services we provide. With a comprehensive network of local sales partners, we are at your call around the clock and around the world.

Your local Linde partner offers you a complete single-source package. From qualified pre-sales consulting through the sale to after-sales service; including finance packages matched to your business requirements. Leasing, rental or hire purchase. Flexibility is maintained in your operational and decision-making processes.

Engineered for your Performance

Linde Material Handling

Linde