



## Electric Tow Tractor

270 lbs. dbp (drawbar pull)  
P60  
SERIES 1191

Linde Material Handling



### Safety

The heavy-duty steel chassis delivers a stable and rugged vehicle. Four independent braking systems ensure effective slowing and stopping in all situations. With emergency disconnect, electronic horn, “fail-to-safe” electronic circuits, the electric system is designed to actively and passively protect the driver.

### Performance

A powerful, 4.5 kW (6 hp) sealed, AC drive motor produces impressive pulling power and up to 12.5 mph (20 kmh) empty speed. The most recent version of LAC (Linde AC Digital Control) efficiently delivers high performance and smooth control and maneuverability.

### Comfort

Convenient access and exit is ensured with ergonomically placed, non-slip steps and wide access openings on either side. To complete the ergonomic layout and operational envelope of the truck, it features a spacious and angled foot well, generous legroom, adjustable seat, intuitive automotive style control levers, adjustable steering wheel and an ergonomic pedal arrangement; providing an unmatched working

environment for every individual operator. Independent suspension on all wheels finalizes the engineering effort to present the best operator work place in its class.

### Reliability

The rugged, heavy gauge steel chassis and impact resistant upper structures allow for maximum structural integrity and protect vital operational components. High quality electrical parts, in conjunction with a heavy-duty drive axle and differential deliver continuous, reliable performance.

### Service

Quality design at all levels results in long component life and extended service intervals. Easy and unobstructed accessibility of all components is an important design standard and keeps time in-between intervals long and service effort minimal. 1000 hours between scheduled maintenance.

# Technical data

June 2015

Characteristics	1.1	Manufacturer					Linde	
	1.2	Model					P60	
	1.2.1	Series					1191	
	1.3	Power					Battery	
	1.4	Operation					Seated	
	1.5	Capacity	Q	lbs (kg)			13000 (6000)	
	1.7	Rated draw-bar pull	lbs (N)	lbs (N)			270 (1200)	1
	1.9	Wheelbase	y	in (mm)			46.9 (1190)	2
Weight	2.1	Weight		lb (kg)		2778 (3340)	1260 (1515)	3,4
	2.3.1	Axle Load laden front		lb (kg)		1212 (1459)	550 (662)	4
	2.3.2	Axle Load laden rear		lb (kg)		1565 (1880)	710 (853)	
Wheels and tires	3.1	Tires (cushion, SE, pneumatic, poly)					Pneumatic	
	3.2	Tire size front					4.00-8 / 6PR	
	3.3	Tire size rear					4.00-8 / 6PR	
	3.5	Wheels number front / rear					1 / 2 x	
	3.6	Track width front	b10	in (mm)			0 (0)	
	3.7	Track width rear	b11	in (mm)			33.9 (860)	2
	Dimensions	4.7	Cabin height	h6	in (mm)			81.5 (2070)
4.8		Seat height	h7	in (mm)			40.1 (1020)	
4.12		Tow pin height	h10	in (mm)		10.6 (270)	12.8 (325) 14.9 (380)	2
4.13		Platform height, unladen	h11	in (mm)			25.4 (645)	
4.16		Platform Length	l3	in (mm)			20.5 (520)	
4.17		Rear overhang	l5	in (mm)			13.8 (350)	
4.18		Loading platform, width	b9	in (mm)			35.4 (900)	
4.19		Overall length	l1	in (mm)			72 (1830)	5
4.21		Overall width	b1/b2	in (mm)			39.2 (996)	6
4.32		Ground clearance	m2	in (mm)			5.3 (135)	
4.35		Turning radius	Wa	in (mm)			64.9 (1650)	
4.36		Inside turning radius	b13	in (mm)			23.6 (600)	
Performance	5.1	Travel speed laden		mp/h (km/h)			7.45 (12)	
	5.1.1	Travel speed empty		mp/h (km/h)			12.5 (20)	
	5.5	Drawbar pull		lbs (N)			270 (1200)	
	5.6	Maximum drawbar pull		lbs (N)			1010 (4500)	
	5.7	Gradeability		%			Contact factory	
	5.10	Service brake					Electric/Hydraulic	
Drive	6.1	Drive motor		hp (kw)		4.5 (AC)		
	6.3	Battery size information				tbd	tbd	
	6.4	Battery voltage					48	
	6.5	Battery weight				tbt	tbt	
Other	8.1	Travel control					Electronic/Stepless	
	8.4	Noise level		dB (A)			60	

1. Based on level and dry surface

2. +/- 5 mm

3. +/- 10 kg

4. in parenthesis with cab

5. +/- 2 mm

6. +/- 20mm

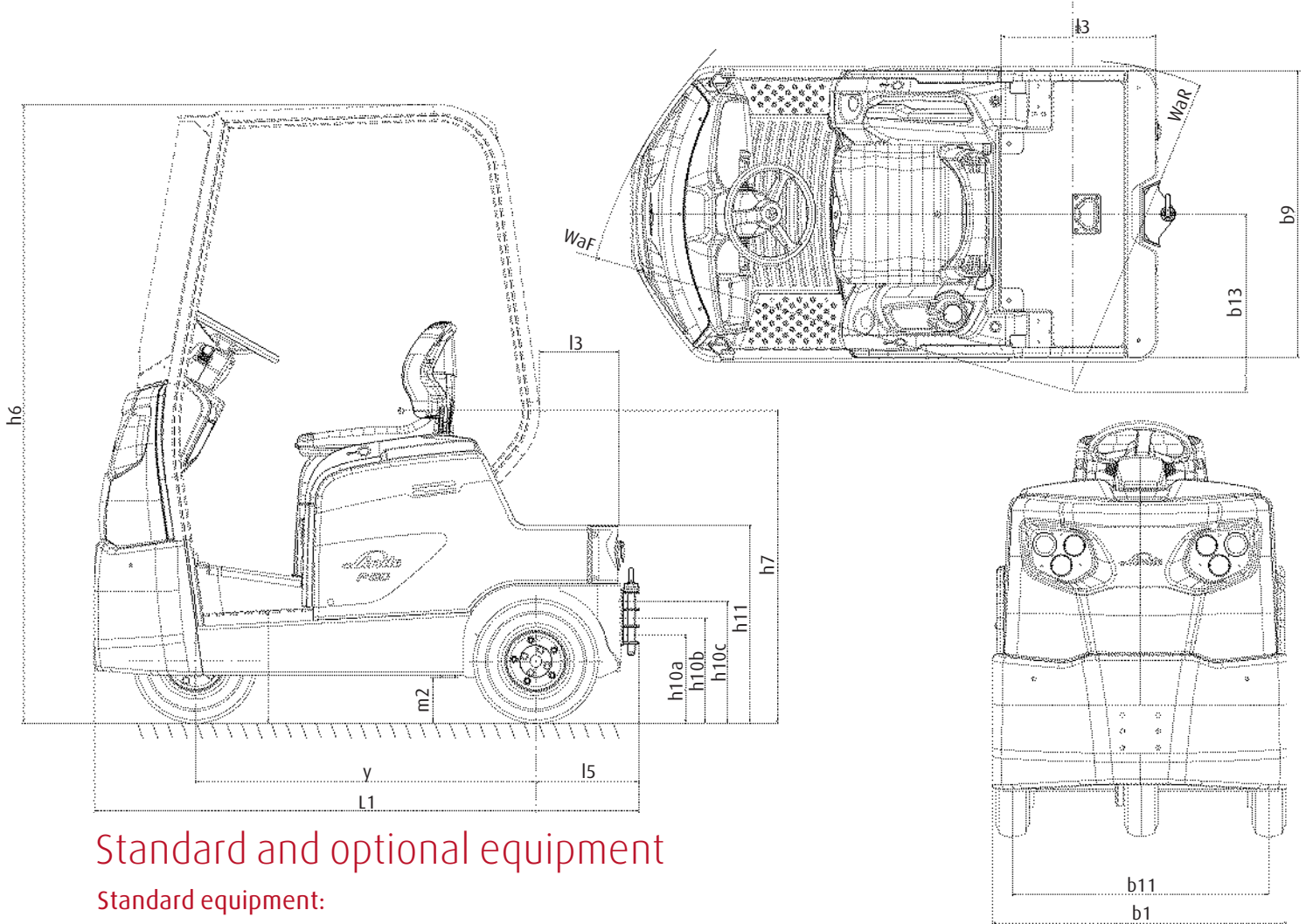

## Standard and optional equipment

### Standard equipment:

#### Standard features

- Exceptional ergonomics
- Extremely spacious driver's compartment
- Power setting: Efficiency
- Two stage travel speed selection
- Generous storage compartments
- Auxiliary power supply socket (12 V) in dashboard
- Key-switch or PIN Code access
- All-wheel, independent suspension

#### General

- Three wheel configuration for best maneuverability
- Excellent stability
- 48V electrical system
- Side battery exchange
- Single pedal travel control with directional lever
- Adjustable PVC covered seat
- Pneumatic tires
- 4.5 kW (6 hp) drive motor, AC, sealed
- Rear, multi-position, towing coupling
- Standard colors – vermilion and charcoal grey

### Optional equipment:

- Linde Curve Speed Assist System
- Lighting systems (bulb or LED)
- Deluxe seat with mechanical suspension
- Super Comfort seat with air suspension and heating
- Operator presence switch (foot switch)
- Adjustable performance parameters (Economy, Efficiency, Performance)
- Various tow hitches, front or rear mounting
- Metal front protection
- Individualized travel speed reduction
- Audible warning in reverse
- Inching control (forward & backward) on both sides at the rear chassis

#### Electronics

- Linde high frequency AC traction controller (LAC)
- Sealed against the ingress of dust and water
- High quality, polarity proof connectors
- Digital interactive display indicating battery discharge status, working hours, power setting, driving direction, malfunction indicators, and further information for optional equipment utilization

#### Safety

- Four independent braking systems:
  - > Regenerative electric braking
  - > Automatic, electro-magnetic, parking brake
  - > Ramp hold control & start assist without roll-back
  - > Self-adjusting hydraulic drum brakes on all wheels
- Emergency electric disconnect
- "Fail-to-safe-circuitry"
- Electronic horn
- Electrical overload protection for motor/controller

- Pedestrian traction buttons (forward traction only) on both sides of the chassis for order picking applications
- Front mounted utility frame, for optional equipment such as mirrors, pad holder, data terminals etc.
- Vertical pole at the rear for optional equipment such as beacon, bin etc.
- Several modular cabin versions (sun protection, roof+screens, plus flexi doors, plus full metal doors, plus cabin heating)
- Efficient and safe side changing design
- Various optional battery changing methods including rollers
- Battery roll-out adapter

### Chassis

- Heavy duty chassis
- Rugged, impact resistant covers
- Independent, all wheel suspension
- Various, optional cab alternatives



### Steering

- Precision steering
- Large lock to lock angle
- Adjustable steering column
- Accurate travelling and maneuvering

### Braking

- Hour independent braking systems:
- Regenerative electric braking
- Self-adjusting hydraulic drum brakes on all wheels
- Automatic parking brake
- Ramp assist (Roll-back control)

### Operator's compartment

- Exceptionally spacious and ergonomic driver's compartment
- Slip resistant step and wide access on both sides
- Spacious foot well and leg room
- Automotive style intuitive control levers

### Towing

- Rear multi-position tow hitch, standard
- Various, optional front and rear tow hitches

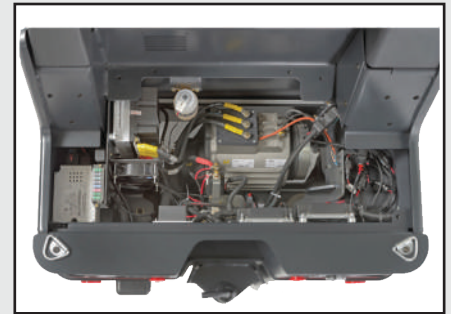
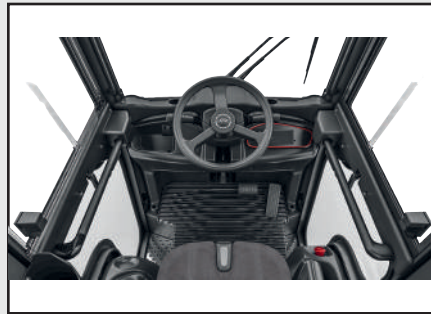

### Controller

- Exceptionally energy efficient Linde digital controller (LAC)
- Smooth, precise travel control
- Programmable performance parameters
- 4.5 kW sealed AC drive motor

### Battery

- Efficient and safe side changing design
- Various battery changing methods
- Long battery life

### Serviceability

- Easy access to all key components
- 1000 hour maintenance interval
- Digital display assists with charging and maintenance planning
- Diagnostic computer port (CAN bus system)

Check with dealer/factory for additional equipment availability.

For more information on Linde material handling equipment, please contact:

KION North America Corporation  
2450 West 5th North Street, Summerville, SC 29483  
Phone: (843) 875-8000 Truck Sales Fax: (843) 875-8471  
E-mail: [trucksales.na@kiongroup.com](mailto:trucksales.na@kiongroup.com)  
[www.kion-na.com](http://www.kion-na.com)



ANSI Standard truck meets all applicable mandatory requirements of ANSI/ITSDF B56.1 standards for powered industrial trucks.  
NOTE: Performance data may vary due to motor and system efficiency tolerances. The performance depicted represents nominal values obtained under typical operating conditions. Metric dimensions are in millimeters unless otherwise specified. All metric dimensions are not direct equivalents due to rounding data. The descriptions and specifications included on this data sheet were in effect at the time of printing. Linde Material Handling North America Corporation reserves the right to make improvements and changes in specification or design without incurring obligation. Please check with your authorized Linde dealer for information on possible updates or revisions.

linde\_spec\_1191\_p60\_0615  
USA\_V11.1\_06312015\_51-0736A