



## POWER DRIVE STRADDLE TRUCKS

**CAPACITY:** 4,000 lbs.

ML20AS

SERIES 8908

### Capacity

- 4,000 lbs. at 24" load center

### Weight

- 2,624 lbs. chassis only

### Wheels / Tires

- Drive: 9" x 3" polyurethane
- Dual load: (2) 4" x 2.9" polyurethane

### Battery Compartments

- Compartment: 31.6" x 13.1" x open
- Anderson 175 Gray, position A-11
- Minimum battery weight: 1090 lbs.



### Standard Equipment

- Regenerative neutral braking
- Creep speed handle control
- Gas-assist spring handle
- Low battery interrupt
- Hour meter BDI combo gauge
- Key switch

### Optional Equipment

- 48" tall load backrest
- Cold conditioning
- Side-shifting fork carriage
- Battery 510 AH 11.9 kWh

## Hydraulics

- Lift cylinder has hard chrome-plated rods
- Pump unit is mounted high in the power compartment for ease of service (includes motor, solenoid, gear pump, and pressure-compensated lowering valve)

## Electrical

- 24-Volt ZAPI AC-0 inverter
- Travel control with matching drive motor provide high performance throughout the entire speed range
- Travel speed remains constant relative to throttle position regardless of load
- Separately-fused power control circuits
- Quick disconnect EPD power cut off
- Hour meter / battery discharge indicator combination gauge
- Power configurations and diagnostic features are displayed with a ZAPI handheld console

## Brakes

- Regenerative electromagnetic brake is mounted on the motor armature shaft multiplying the braking power through the drive transmission
- Brake is applied when the control arm is in the vertical or horizontal handle position
- Anti-roll back and neutral braking

## Controls

- Travel, lift, and lower functions are located in the ergonomic operator handle
- All operator controls are accessible without having to lift the hand from the handle
- Angle grips are designed to allow easy operation with either hand
- Wraparound guard, reversing switch, thumb control, and horn are standard
- Top-mounted tiller arm offers excellent operator comfort and minimum steering effort
- Gas-assisted spring gently returns handle to vertical position

Model #	Mast	Lift Height	Col Height	Free Lift	Ext Height w/LBR	Fixed Straddle Leg <sup>2</sup>		Weight Chassis Only <sup>3</sup>
		A	C	D	E	F	G	
4,000 lbs. capacity at 24" load center ITA Class II fork carriage								
ML20AS	Telescopic	104	72	6	142	42 or 50	50 or 58	2042
ML20AS	Telescopic	126	83	6	165	42 or 50	50 or 58	2172
ML20AS	Telescopic	142	91	6	178	42 or 50	50 or 58	2239
ML20AS	TriMast	157	72	50	193	42 or 50	50 or 58	2444
*ML20AS	TriMast	177	80	58	213	42 or 50	50 or 58	2539

\*Derates 1500 lbs. above 162" <sup>2</sup>ML20AS only available with fixed straddle legs <sup>3</sup> Estimated shipping weight without battery

Aisle Guide  
ML20AS - Right angle stacking

Load Size	36" length	40" length	48" length
36" width	79.5"	79.5"	79.5"
40" width	80.5"	80.5"	80.5"
48" width	80.5	80.5	80.5

For ease of use add 8" to aisle dimension listed. If sideshift option is used add 2".

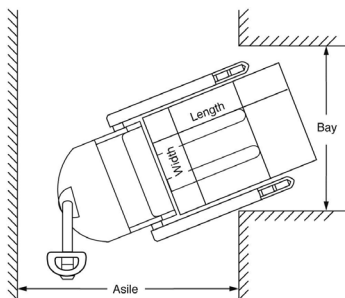

Aisle dimensions listed above assume the minimum bay width to be straddle OD plus 5" (2.5" on either side of straddle leg). Straddle OD is the load width plus 10". Truck performance may vary due to application requirements and changes in model design.

For more information on Linde material handling equipment, please contact:

KION North America Corporation  
2450 West 5th North Street, Summerville, SC 29483  
Phone: (843) 875.8000 Truck Sales Fax: (843) 875.8471  
Email: trucksales.na@kiongroup.com  
www.kion-na.com

## Transmission

- Vertically-mounted drive motor is direct mounted to gear housing
- Oil-bathed bevel gear drive train with tapered roller bearings transfers power to axle
- State-of-the-art optimized gear technology supplies advantages such as minimal envelope circle, zero maintenance, low noise level, high efficiency and high performance

## Frame and Mast

- Bolt-on high visibility mast
- I-beam construction with lift cylinders positioned on the outer I-beam for best view through mast
- Dual lifting chains
- Fixed straddle leg inside dimension (ID) can be set at 42" or 50"
- Four-inch-wide straddle legs = ID + 8"
- Class II ITA fork carriage with 36" tall load back rest
- Forks are adjustable from 8" ID to 31" OD

## Straddle Legs & Forks

- Fixed straddle leg inside dimensions (ID) available at 34" or 42" resulting in a 42" or 50" outside dimension (OD)
- Class II ITA fork carriage with 36" tall load back rest
- 42" forks are adjustable

## Bearings

- Drive wheel: Tapered roller bearings sealed in oil bath
- Load wheel: Sealed ball bearings

## Accessibility

- Removal of two-piece power head cover exposes major components for inspection and maintenance

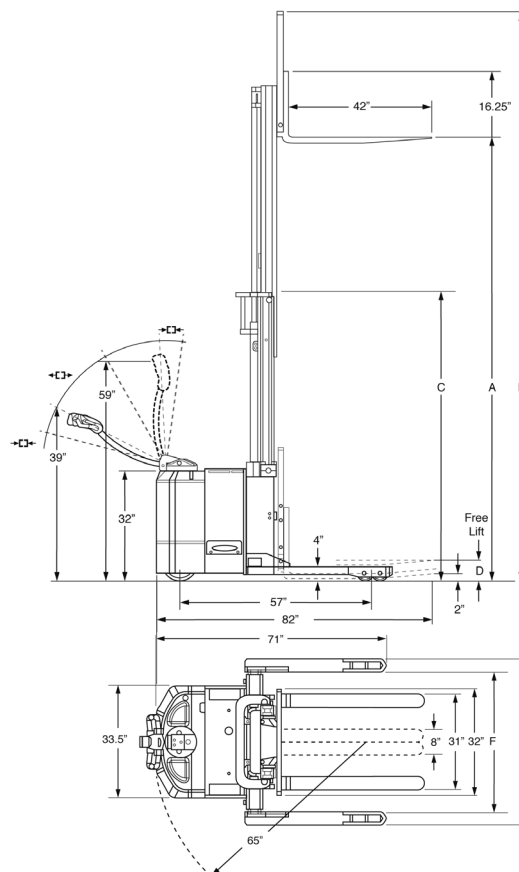

ANSI: Standard truck meets all applicable mandatory requirements of ANSI/ISO/IEC 1 standards for powered industrial trucks. All other values obtained under typical operating conditions. Metric dimensions are in millimeters unless otherwise specified. All metric dimensions are not direct equivalents and may vary slightly from the imperial dimensions. The descriptions and specifications included on this data sheet were in effect at the time of printing. KION North America Corporation reserves the right to make improvements and changes in specification or design without notice and without incurring obligation. Please check with your authorized Linde dealer for information on possible updates or revisions.

Linde Material Handling

*Linde*

KION NORTH AMERICA

linda\_spec\_8908\_ML20AS  
USA\_V1\_20190307