

FORKLIFT TRUCK

SCP160A-6

STANDARD FEATURES

- ➔ Enclosed cab with automatic climate control and with a high back
- ➔ Powered tilting cab
- ➔ Reverse camera with object detection system
- ➔ Powerful Cummins engine

35,000 lbs

Rated Load Capacity

42,990 lbs

Weight Without Load

130"

Wheelbase

Cummins Diesel

Engine

DIMENSIONS

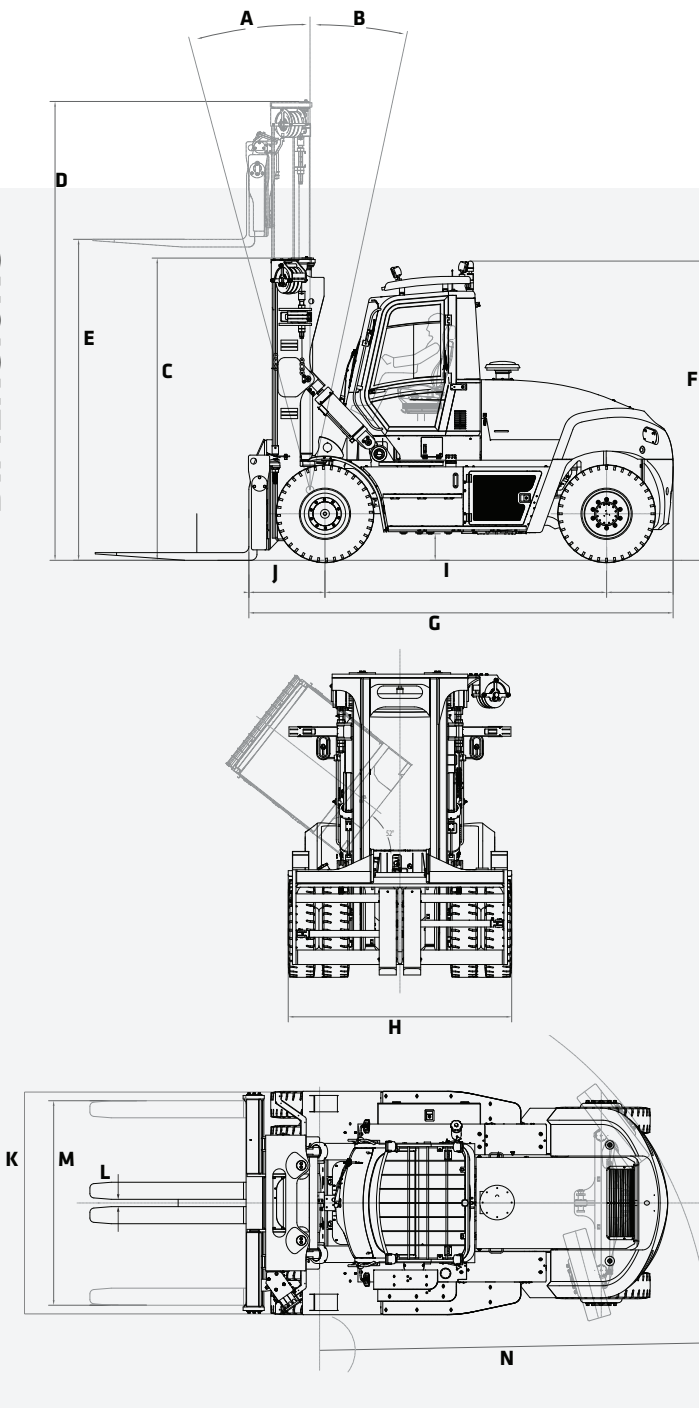

DIMENSIONS

MAST

A	Forward Tilt	12°	
B	Back Tilt	15°	
C	Height Lowered	140"	3 545 mm
D	Height Extended	212"	5 380 mm
E	Lift Height	148"	3 760 mm

OVERALL

F	Cab height	138"	3 510 mm
G	Length to Load Face	196"	4 970 mm
H	Width	103"	2 370 mm
I	Wheelbase	130"	3 300 mm
J	Load Distance	35"	891 mm

FORK

	Thickness	3.5"	90 mm
	Width	8"	200 mm
	Length	96"	2 440 mm

CARRIAGE

K	Width	99"	2 520 mm
---	-------	-----	----------

FORK SPREAD

L	In-In Minimum	3.4"	86 mm
M	Out-Out Maximum	94.3"	2 396 mm

GROUND CLEARANCE

	Minimum Ground Clearance	11.8"	300 mm
--	--------------------------	-------	--------

AISLE WIDTH

	With Load Length	319"	8 102 mm
--	------------------	------	----------

TURNING RADIUS

N	Outside	180"	4 571 mm
---	---------	------	----------

In the interest of continual equipment development, SANY Canada Ltd. reserves the right to change these specifications at any time without prior notification.
©2023 SANY Canada Ltd.

STANDARD AND OPTIONAL EQUIPMENT

s = standard / o = optional

SCP160A-6	ENGINE
s	QSB 6.7l Cummins Diesel with 164HP @ 2,300rpm
s	Tier 4 Final EPA Emissions Compliant
s	High Intake, Long Life Air Filter w/ Safety Element
s	Fuel Filter with Water Separator
s	Variable Geometry Turbocharger
s	500-Hr Engine-Oil-Change Interval
s	Electronic Controlled
s	24V, 70A Alternator
DRIVETRAIN	
s	Dana TE-10 Transmission
s	3 FWD & 3 REV gears
s	Kessler D81 Drive Axle
s	Heavy Duty Wet Disc Brakes
s	Electronically Actuated Parking Brake
s	6 x 12.00-20 Pneumatic Tires
MAST	
s	Duplex Mast, MFH 148", OALH 140", EXT 212"
o	Duplex Mast, MFH 196", OALH 164", EXT 261"
s	Hook Type Carriage
o	Apron Type Carriage
s	Simultaneous and Independent Fork Positioner
o	Side Shift Carriage
s	96" x 7.87" x 3.54" Pin Type Forks
CABIN	
s	High Visibility Enclosed Cabin w/ Curved Glass
o	Grammer Air Suspension Cloth Seat
s	Climate Control with A/C and Heat
s	Ergonomic Multifunction Joystick
o	Individual Hydraulic Control Levers
s	Telescoping and Tilting Steering Column

STANDARD AND OPTIONAL EQUIPMENT

s = standard / o = optional

SCP160A-6	CABIN (CONTINUED)
s	Steering Wheel Spinner Knob
o	AM/FM Radio with 2 Speakers and USB Connectivity
s	Front, Rear and Top wiper
s	Top Retractable Sun Shade
s	12V/24V Power Supply
s	Push Button Applied Park Brake
o	Reading Light
s	Exterior Cabin Mounted Mirrors
s	Powered Tilting Cabin for Ease of Maintenance
ACCESSORIES	
o	Reverse Camera w/ 7" Color Display
s	Rear Object Detection Sensor up to 10"
s	Common Greasing Points for Steer Axle and Mast
s	Automatic Engine Fire Extinguisher
s	Locking Fuel Cap
o	Travel Speed Limiter
o	Integrated Tire Pressure Monitoring System
o	Extreme Cold Climate Package (Fuel, Engine and Hydraulics)
o	Customized Colors or Labels
s	Lockable Battery Disconnect Switch
o	Steer Wheel Lug Nut Protection
o	Rear Lifting Eyes
LIGHTS	
s	2 Front Fender Mounted LED Lights
s	2 Front Cab Mounted LED Lights
s	2 Rear Cab Mounted LED Lights
s	2 Mast Mounted LED Working Lights
o	Indicator and Hazard lights
o	Rotating Amber Beacon
o	Additional LED Lights

PRODUCT SPECIFICATIONS FORKLIFT TRUCKS || SCP160A-6

WORKING RANGE

SPECIFICATIONS		
GENERAL		
Rated Load Capacity	35,000 lbs	16 000 kg
Load Center	24"	610 mm
Load Distance	35"	891 mm
Wheelbase	130"	3 300 mm
Hydraulic Tank Capacity	48 gal	180 l
Fuel Tank Capacity	71 gal	270 l
WEIGHTS		
Total Truck Weight without Load	42,990 lbs	19 300 kg
Axle Loading with Load		
Front	72,530 lbs	32 900 kg
Rear	5,730 lbs	2 600 kg
Axle Loading without Load		
Front	21,160 lbs	9 600 kg
Rear	21,830 lbs	9 900 kg
WHEELS		
Tire Type	Pneumatic	
Tire Size		
Drive	12.00-20 20PR	
Steer	12.00-20 20PR	

LIFTING PERFORMANCE

PERFORMANCE		
SPEED		
Travel		
With Load	15.5 mph	25 km/h
Without Load	16.8 mph	27 km/h
Lifting		
With Load	69 ft/min	0.35 m/s
Without Load	79 ft/min	0.40 m/s
Lowering		
With Load	98 ft/min	0.5 m/s
Without Load	94 ft/min	0.48 m/s
DRAWBAR		
Pull-Max	30,350 lbf	135 kN
GRADEABILITY @ 1 MPH (1.6 KM/H)		
With Load	33%	

In the interest of continual equipment development, SANY Canada Ltd. reserves the right to change these specifications at any time without prior notification.

POWERTRAIN		
ENGINE		
Type	Cummins QSB 6.7 Diesel	
Emmissions Type	EPA Tier 4 Final	
Output		
Rated	164 hp	122 kW
Governed Speed	2,300 rpm	
Cylinders		
Number	6	
Disp	6.7 l	
Turbocharger	Variable geometry	
ALTERNATOR		
Amps	24V	120A
Drive Axle	Kessler D81	
Transmission	Dana TE10	
GEARS		
Forward	3	
Reverse	3	
BATTERY		
Capacity	24 V 120 Ah	
BRAKES		
Service	Wet Disc	
Parking	Dry Disc	
TANK CAPACITY		
DEF	5 gal	19 l

MAST		
TYPE	Duplex	
*Height Maximum	148"	3 761 mm
*OALH	140"	3 545 mm
*Extended	212"	5 380 mm
*Freelift	-	-
Fork Type	Pin	
Carriage Type	Hook	

* All imperial numbers have been rounded to the nearest whole number.
*Additional mast heights available.



MONTREAL (Head office)
100A, Hymus Blvd.
Pointe-Claire (Québec) H9R 1E4

Phone: 514 694-4223
Toll free: 1 866 421-4223

info@elevex.ca



QUEBEC
1279, Paul-Émile Giroux St. Suite
200 Québec (Québec) G1C 0K9

SAGUENAY
2305, Alexis-Le-Trotteur
St. Jonquière (Québec) G7X 9H8



elevex.ca