

# SCPE100

SANY HEAVY DUTY FORKLIFT TRUCKS



The cost for electric heavy duty forklift is 80,000 CNY(2000h) less than for fuel ones per year

Due to the fluctuation of electricity price and oil prices and other factors, the relevant data may vary



OVERALL WEIGHT  
**13500kg**

RATED LOAD  
**10t**

LIFTING HEIGHT  
**3m**



## ► Product Parameters

Technical Parameter		
ITEM	UNIT	SCPE100
Overall weight	t	13.5
Rated capacity	t	10
Lift speed (laden/unladen)	mm/s	450/500
Lowering speed (Laden/unladen)	mm/s	500/450
Travel speed (laden/unladen)	km/h	25/25
Gradeability (laden)	%	27
Length overall L	mm	5724
Width overall W	mm	2408
Height overall H	mm	3435
Load center L1	mm	600
Wheel base L2	mm	2700
Overhang front L3	mm	745
Overhang rear L4	mm	779
Ground clearance H2	mm	275
Seat height above ground H4	mm	1992
Inner turning radius R1	mm	325
Outer turning radius R2	mm	4000
Front track width W1	mm	1728
Rear track width W2	mm	1960
Mast height (Retracted H /extended H1)	mm	3398/4868
Lift height standard H3	mm	3000
Mast tilt (forward/backwards)	deg	6/12

Configuration Parameter			
CONFIGURATION		UNIT	SCPE100
Engine	Brand	-	Huichuan
	Rated capacity	kW/rpm	105
Engine	Brand	-	Huichuan
	Rated capacity	kW/rpm	63
Battery	Brand	-	CATL
	Rated voltage	V	521
	Rated electric quantity	kWh	90
Drive axle brand		-	SANY
Forks	Dimension (Length×width×height)	mm	1500×200×75
	Fork distance (Minimum-maximum)	mm	485~2245
	Applicaton	-	ISO 20'container, large tonnage or bulk cargo
Tire dimension		-	9.00-20PR

## ► Dimensions

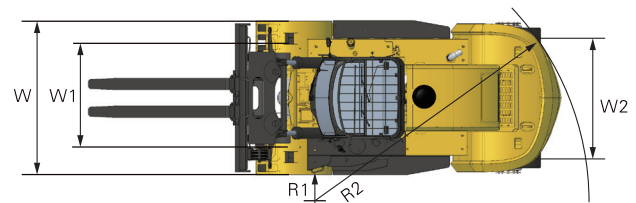
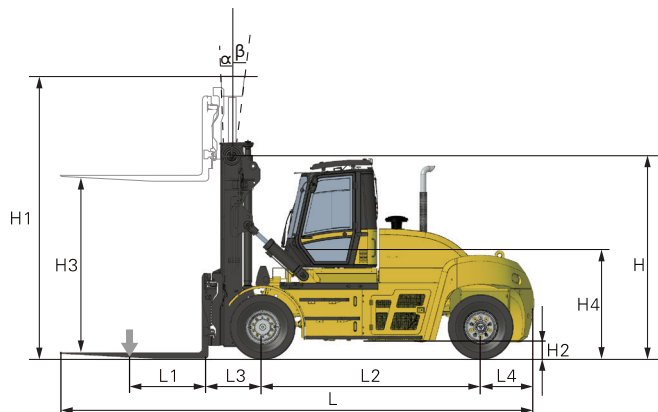

**MONTREAL (Head office)**  
100A, Hymus Blvd.  
Pointe-Claire (Québec) H9R 1E4

Phone: 514 694-4223  
Toll free: 1 866 421-4223

[info@elevex.ca](mailto:info@elevex.ca)

**QUEBEC**  
1279, Paul-Émile Giroux St. Suite  
200 Québec (Québec) G1C 0K9

**SAGUENAY**  
2305, Alexis-Le-Trotteur  
St. Jonquière (Québec) G7X 9H8



[elevex.ca](http://elevex.ca)