



Electric Man-Down Turret Truck Capacity up to 1350 kg A

SERIES 5022



Linde Material Handling

Linde

Safety

The new Linde A Man down range is a versatile VNA system truck designed for high density storage and retrieval of unit loads in very narrow aisles. In addition to modern, functional styling, the A range provides an environment in which the operator can work in complete comfort and safety.

Performance

Intuitive use of the control panels enables throughput of goods to be increased without removing the hands. The operator can check the truck's status via the multifunctional display. Designed for low energy consumption, the truck also returns energy to the battery during braking and mast lowering.

Comfort

A perfect interface between operator and truck has been achieved with the Linde ergonomic design concept, including spacious cab, comfort class seat and intuitive layout of all controls. The operators working environment ensures optimum performance.

Reliability

Linde has used its vast experience in very narrow aisle applications, in conjunction with the latest technology available to ensure the new A range is a high quality product with exceptional product life. CAN bus diagnostics enable rapid fault finding and repair helping to achieve exceptional levels of truck uptime.

Productivity

The unique modular design ensures that an individual truck specification can be tailored to match the application precisely in order to maximise productivity at all times. The smart electronics of Linde System Control (LSC) continuously monitors the truck's technical potential in order to deliver optimum simultaneous lift and travel speeds relative to lift height and load weight.

Technical data (according to VDI 2198)

Characteristics	1.1	Manufacturer		LINDE	LINDE	LINDE
	1.2	Manufacturer's model designation		A	A	A
	1.3	Power unit		Battery	Battery	Battery
	1.4	Operation		Seated	Seated	Seated
	1.5	Load carrying capacity	Q (kg)	1000	1350	1350
	1.6	Load centre	c (mm)	600	600	600
	1.9	Wheelbase	y (mm)	1595	1739	1943
Weight	2.1	Weight (incl. battery)	kg	5114	5985	6634
	2.3	Axle loadings without load front/rear	kg	1855/3259	2176/3809	2531/4102
Wheels	3.1	Tyres		Polyurethane	Polyurethane	Polyurethane
	3.2	Tyre size, front	mm	360/140	360/140	360/140
	3.3	Tyre size, rear	mm	370/160	370/160	370/160
	3.5	Wheels, number front/rear (x=drive wheel)		1x/2	1x/2	1x/2
	3.6	Track width, front	b10 mm	1290	1290	1290
	3.7	Track width, rear	b11 mm	-	-	-
Basic dimensions	4.2	Height of mast, lowered	h1 (mm)	3400	3900	2900
	4.3	Free lift	h2 (mm)	-	-	1650
	4.4	Lift height	h3 (mm)	4600	5200	5050
	4.5	Height, mast raised	h4 (mm)	6050	6650	6500
	4.7	Height to top of overhead guard	h6 (mm)	2200	2200	2200
	4.8	Seat height	h7 (mm)	1050	1050	1050
	4.15	Fork height lowered	h13 (mm)	60	60	60
	4.19	Overall length (incl. forks)	l1 (mm)	2884	3028	3232
	4.21	Overall width	b1/b2 (mm)	1250/1500	1250/1500	1250/1500
	4.22	Fork dimensions	s/e/l (mm)	50/120/1200	50/120/1200	50/120/1200
	4.23	Fork carriage to DIN 15173 / class/form A, B, no	(mm)	Special	Special	Special
	4.24	Width of fork carriage	b3 (mm)	710	710	710
	4.25	Width of forks min./max.	b5 (mm)	500/640	500/640	500/640
	4.27	Width over side guide rollers	b6 (mm)	1675	1645	1645
	4.29	Lateral reach travel	b7 (mm)	1400	1308	1308
	4.31	Ground clearance beneath mast, laden	m1 (mm)	40	40	40
	4.32	Ground clearance at centre of wheelbase	m2 (mm)	80	80	80
	4.34	Aisle width	Ast (mm)	1740	1650	1650
	4.35	Turning radius	Wa (mm)	1826	1970	2174
	4.38	Centre of axle to fork pivot	l8 (mm)	703	703	703
	4.39	Head centre	A (mm)	480	480	480
	4.40	Width of reach carriage	B (mm)	1560	1465	1465
4.41	Head width	F (mm)	250	250	250	
4.42	Transfer aisle width (min.)	Au (mm)	3346	3490	3694	
Performance	5.1	Travel speed, with/without load	km/h	10.5/10.5	10.5/10.5	10.5/10.5
	5.2	Lift speed, with/without load	m/s	0.56/0.70	0.51/0.55	0.52/0.55
	5.3	Lowering speed, with/without load	m/s	0.55/0.55	0.55/0.55	0.55/0.55
	5.4	Reach speed, with/without load	m/s	0.30/0.45	0.30/0.45	0.30/0.45
	5.9	Acceleration time, with/without load	s	5/5	6/6	6/6
	5.10	Brakes		Regenerative	Regenerative	Regenerative
E-motors	6.1	Drive motor, Power	kW	6.5kW/S2=60min	6.5kW/S2=60min	6.5kW/S2=60min
	6.2	Lift motor, Power	kW	24.0kW/S3=15%	24.0kW/S3=15%	24.0kW/S3=15%
	6.3	Battery		IEC 254-2; C	IEC 254-2; C	IEC 254-2; C
	6.4	Battery type, voltage, capacity (5h)	V/Ah	PzS, 48 V, 700 Ah	PzS, 48 V, 980 Ah	PzS, 48 V, 1120 Ah
	6.5	Battery weight (± 5 %)	kg	1119	1498	1688
Misc	8.1	Type of drive control		Microprocessor	Microprocessor	Microprocessor
	8.4	Noise level at operator's ear	dB (A)	68	68	68

Values can vary ± 10 %. The calculated speed profiles are based on our floor quality rules. Subject to change without notice.

Exemplary configuration based on modular system. Please contact your local sales department for an individual truck configuration.

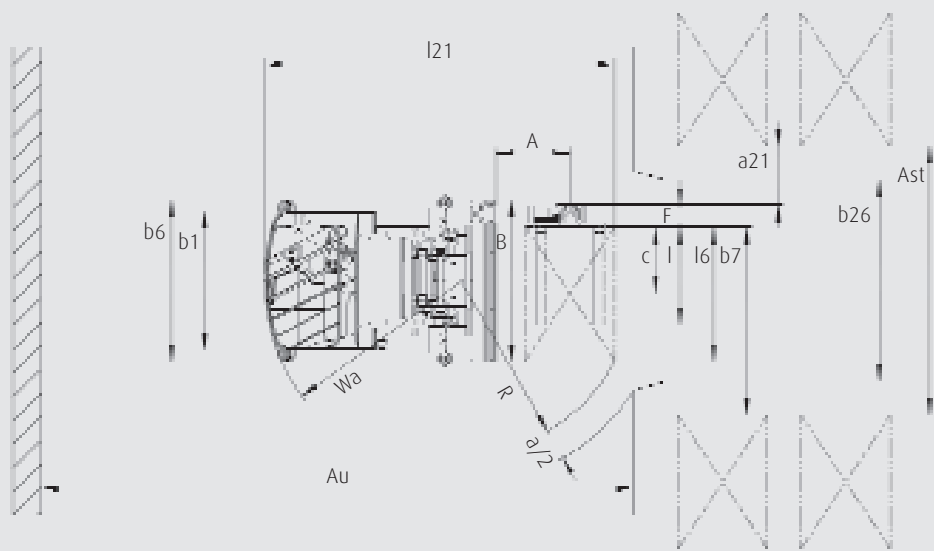
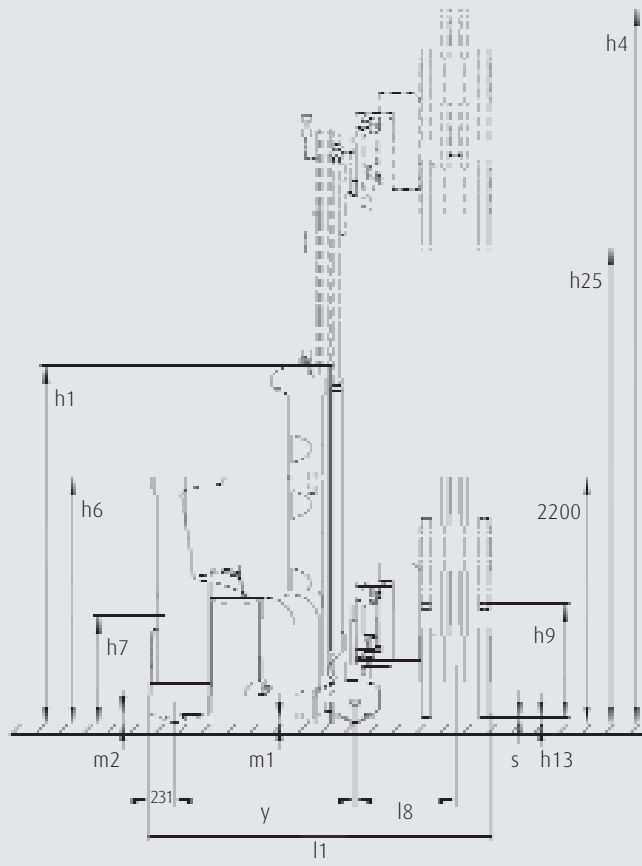

Standard 1 000 kg						
	Total lift above floor	Main lift	Height lowered	Auxiliary lift (2)	Maximum height (1)	
	h1	h25	h3	h13	h9	h4
	4 900	8 655	7 600	60	995	9 800
	4 400	7 655	6 600	60	995	8 800
	3 900	6 655	5 600	60	995	7 800
	3 400	5 655	4 600	60	995	6 800
	2 900	4 655	3 600	60	995	5 800
	2 400	3 655	2 600	60	995	4 800
	2 200	3 255	2 200	60	995	4 400

Standard 1 350 kg						
	Total lift above floor	Main lift	Height lowered	Auxiliary lift (2)	Maximum height (1)	
	h1	h25	h3	h13	h9	h4
	4 900	8 255	7 200	60	995	9 400
	4 400	7 255	6 200	60	995	8 400
	3 900	6 255	5 200	60	995	7 400
	3 400	5 255	4 200	60	995	6 400
	2 900	4 255	3 200	60	995	5 400
	2 400	3 255	2 200	60	995	4 400
	2 200	2 855	1 800	60	995	4 000

Triplex 1 350 kg						
	Total lift above floor	Main lift	Freelift	Height lowered	Auxiliary lift (2)	Maximum height (1)
	h1	h25	h3	h2	h13	h9
	3 900	8 505	7 450	2 650	60	995
	3 400	7 405	6 350	2 150	60	995
	2 900	6 105	5 050	1 650	60	995
	2 400	4 605	3 550	1 150	60	995
	2 200	4 005	2 950	950	60	995

AST Data					
	Pallet size	Stacking depth	Ast (3)	AU-min	Au-opt (3)
euro	1 200 x 800	1 200	1 630	3 202	plus 500
	800 x 1 200	800	1 275	3 539	plus 500
chep	1 200 x 1 000	1 200	1 630	3 368	plus 500
	1 000 x 1 200	1 000	1 430	3 505	plus 500

h25 = h3 + h9 + h13
 1. Without auxiliary lift: h4 - 750 mm
 2. Without auxiliary lift: h25 - 995 mm

3. Values depend on guidance system.
 For confirmation of AST and AU please contact your local sales and service dealer.



Equipment

Standard options

Modular designed truck for perfect customization

Operators compartment

Hydraulically damped operators fabric seat with weight, rake, lumber support and longitudinal adjustment

Ergonomic multifunctional controls

Truck access via key

Low step in height for easy access to drivers compartment

Basic functions without changing position of grip

Multi purpose display with keypad

Storage compartments, pen holders and space for bottles, cans or tools integrated

Clear and distinct control layout

LCD Display (guidance/ capacity/ steer angle/ battery and operating state/ operating hours/ lift height/ speed/ service info)

Side seated operation

All round visibility with the ergonomically designed overhead guard

Overhead guard with head cushion

Throughput

LSC standard

Synchronized lowering

Synchronous swivel

Energy recovery when braking or lowering the mast

Mast /Forks

L-head or telescopic forks

Motors

13 KW lift motor

6,5 KW drive motor

Safety

Warning light mounted on overhead guard (active during all movements)

Optional equipment

Operators compartment

Comfortable seats (heated, synthetic leather)

Wire mesh or makrolon overhead guard cover

Radio preparation

Rearview (left/right) and panorama mirror

Clipboard DIN A4

Lighting for operators compartment

Working lights into rack

Pin code access

Linde LFM management system

Throughput

LSC with load recognition, load sensor or weight and load recognition

Synchronous swivel with stop at 90 degrees

Automatic fork cyclus

Overreach facility of forks up to 55 mm

Twin pedal system

Pallet positioning aid

Lift height preselection

Loadwheel brake for increased travel speed

Drive

Different drive and lift motors available

Rail or wire guidance options

Safety

Different speed reductions and aisle stop functions

Personal safety equipment (PSE)

Lifting and driving cut off

Audible warnings

Camera systems for driving and pallet handling

Masts / Forks

Standard masts 1000 kg capacity up to 8655 mm lift height

Standard masts 1350 kg capacity up to 8255 mm lift height

Triplex masts 1350 kg capacity up to 8505 mm lift height

Auxiliary lift (h9=995 mm)

Alternative fork lengths for different pallet sizes

Manual or hydraulically adaptable forks

Gear rack cover for L-head

Battery

Alternative battery capacities

Battery mounted on rollers for side change

Battery roller stands

Electrical verification for battery lock

Cable for additional battery

Environment

Antistatic guide rollers

Antistatic for inductive guidance

Service

Online diagnosis tool

Features

Cabin

- Side seated operation allows the truck operator to have excellent vision during both forward and reverse traction of the truck
- This driving position also allows the operator to park the truck in aisle, and exit the cab safely
- Comfortable working space for increased throughput
- Various comfortable and adjustable seat options
- Different storage compartment options are available to suit individual customer requirements

Modular concept

- Unique modular designed truck enables the perfect specification for each application
- Combination of different lift and drive motors, chassis, masts, batteries, cabins, etc. to suit each application



Drive and lift

- High performance AC drive and Lift motors are fitted as standard
- Optional motor sizes allow the truck performance to be matched to customer requirements

Control concept and display

- The high contrasting LCD display gives excellent driver information
- Fatigue free working due to ergonomic positioned multifunction joystick
- The simple ergonomic controls allow precise, accurate function control, once again reducing driver fatigue and increasing truck throughput



Batteries

- Easy and quick battery change with truck battery rollers and static battery stands
- The modular system allows batteries from 465 to 1240Ah to be fitted

Linde System Control (LSC)

- The Linde system control (LSC) represents a significant advance in the smart control of Man down VNA trucks
- LSC Standard 3.0. Dynamical diagram of residual capacity depending on the actual speed and lifting heights
- LSC with load recognition 3.1. Detection of load, additional lifting functions are adjusted
- LSC with load sensor 3.2. Detection of load, additional lifting functions are adjusted as well the driving parameters
- LSC with weight and load recognition 3.3. Driving profile depending on the actual transported weight plus the 3.1 optimization

Mast

- Standard and triplex mast options are available up to 1350kg capacity
- The slim mast design gives excellent vision when both stacking and retrieving pallets
- A rigid, strong mast design helps reduce mast sway, therefore increasing truck cycle times

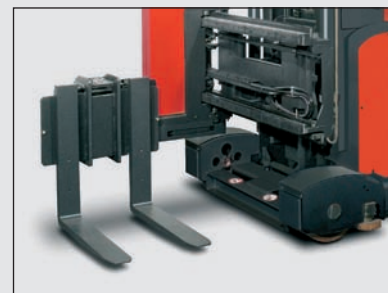

Camera and Positioning

- Optional positioning systems are available helping to give high throughputs
- Easier pallet handling at height through camera system
- Safe driving with camera

Subject to modification in the interests of engineering progress. Illustrations and technical details non-binding for actual construction. All measurements subject to customary tolerances.

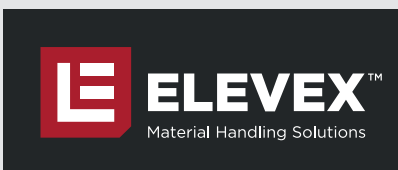

MONTREAL (Head office)
19151 A, Cruickshank Avenue
Baie-D'Urfé (Québec) H9X 3N9
Phone: 418 694-4223
Toll free: 1 866 421-4223
info@elevex.ca
elevex.ca

QUEBEC
1279, Paul-Émile Giroux St. Suite
200 Québec (Québec) G1C 0K9

SAGUENAY
2305, Alexis-Le-Trotteur
St. Jonquière (Québec) G7X 9H8

