



ME 8C - 10C

- Voltage 24V
- Traction motor AC
- Electronic lift control
- Cushion tires
- Power steering
- Masts from 114" to 224"
- Integrated sidsifter
- Right Angle Stack 106.5"

ME 10 - 12

- Voltage 36V
- Traction motor AC
- Electronic Lift Control
- Cushion tires
- Power steering
- Masts from 114" to 224"
- Integrated sidsifter
- Right Angle Stack 112.3"

MAST DETAILS ME 8C - 10C

HEIGHT		STANDARD INCL. SIDE-SHIFT				DUPLEX INCL. SIDE-SHIFT				TRIPLEX INCL. SIDE-SHIFT			
Lift height	h_{23}	114.0	126.0	150.0	165.0	114.0	126.0	150.0	165.0	171.0	189.0	224.0	
Closed mast height	h_1	75.1	81.1	92.9	100.8	75.1	81.1	92.9	100.8	75.1	81.1	92.9	
Height mast extended *	h_4	154.7	166.5	190.2	205.9	154.7	166.5	190.2	205.9	211.8	229.5	265.0	
Free lift	h_2	-	-	-	-	58.2	64.2	76.0	83.9	58.2	64.2	76.0	
Overall width ME 8C	b_1	31.7	31.7	34.3	34.3	31.7	31.7	34.3	34.3	34.3	34.3	35.6	
Overall width ME 10C	b_1	33.5	33.5	36.0	36.0	33.5	33.5	36.0	36.0	36.0	36.0	37.4	

* With Backrest

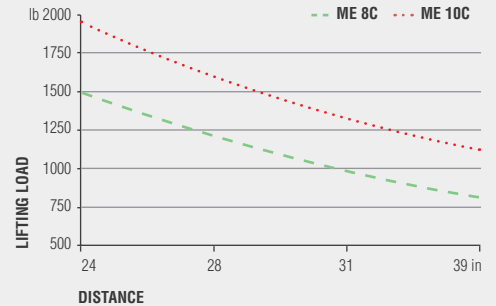

MAST DETAILS ME 10 - 12

HEIGHT		STANDARD INCL. SIDE-SHIFT				DUPLEX INCL. SIDE-SHIFT				TRIPLEX INCL. SIDE-SHIFT			
Lift height	h_{23}	114.0	126.0	150.0	165.0	114.0	126.0	150.0	165.0	171.0	189.0	224.0	
Closed mast height	h_1	76.0	81.9	93.7	101.6	76.0	81.9	93.7	101.6	76.0	81.9	93.7	
Height mast extended *	h_4	154.7	166.5	190.2	205.9	154.7	166.5	190.2	205.9	211.8	229.5	265.0	
Free lift	h_2	-	-	-	-	58.3	64.3	76.2	84.0	58.3	64.3	76.2	
Overall width ME 10	b_1	33.9	33.9	33.9	36.2	33.9	33.9	33.9	36.2	36.2	36.2	37.8	
Overall width ME 12	b_1	35.0	35.0	35.0	37.4	35.0	35.0	35.0	37.4	37.4	37.4	39.0	

* With Backrest

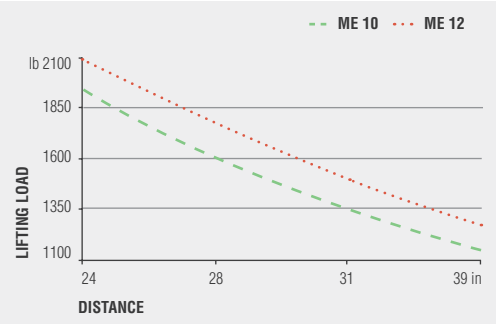

Data showed are not binding and are liable to variations.
The constructor reserves the right of changes without notice.

★ On demand installation of the strobo light under the height of the overhead guard **h6**

Non-standard tyres, different masts, optional equipment, etc. may result in different values.

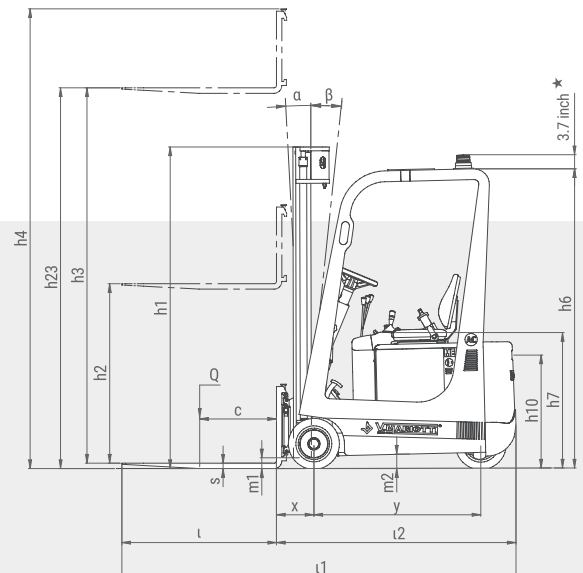
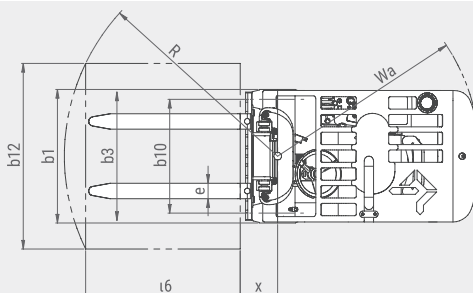

	1.1	Manufacturer		V.MARIOTTI S.r.l.		V.MARIOTTI S.r.l.			
	1.2	Model		ME 8C	ME 10C	ME 10	ME 12		
CHARACTERISTICS	1.3	Type of drive		Electric	Electric	Electric	Electric		
	1.4	Operator type		driver sitting	driver sitting	driver sitting	driver sitting		
	1.5	Load capacity/rated load	Q	lb	1500	1950	1950	2100	
	1.6	Load centre distance	c	in	24	24	24	24	
	1.8	Load distance	x	in	8.7 ●	8.7 ●	9.5 ●	9.5 ●	
	1.9	Wheel base min / max (adjustable)	y	in	36.3 / 39.6	36.3 / 39.6	41.7 / 45	41.7 / 45	
	WEIGHTS	2.1	Net weight incl. battery (see row 6.5)		lb	3417 ■	4211 ■	4189 ■	4740 ■
		2.2	Axle load. with load. front / rear		lb	4343 / 838	5490 / 926	5512 / 882	6371 / 1014
2.3		Axle load. without load. front / rear		lb	1345 / 2072	1631 / 2579	1874 / 110	1918 / 2822	
WHEELS	3.1	Tires: Solid pneumatic (SE). Cushion (V)			V	V	V	V	
	3.2	Tire size front		in	11.8x4.7x8	11.8x5.7x8	13x5x8	13x8x8	
	3.3	Tire size rear		in	11.8x4.7x8	11.8x5.7x8	13x5x8	13x8x8	
	3.5	Wheels. number front/rear (◆ = driven wheels)			2 / 1 ◆	2 / 1 ◆	2 / 1 ◆	2 / 1 ◆	
	3.6	Track width. front	b ₁₀	in	27	27.8	29	29.2	
DIMENSIONS	4.1	Tilt of mast/fork carriage forward/backward		α/β	<°	2° 40' / 5° 30'	2° 40' / 5° 30'	2°40' / 5° 50'	2°40' / 5° 50'
	4.2	Closed mast height		h ₁	in	75.1	75.1	82.3	82.3
	4.3	Free lift		h ₂	in	\	\	\	\
	4.4	forks lifting		h ₃	in	113	113	124.6	124.6
		Lifting height		h ₂₃	in	114	114	126	126
	4.5	Height mast extended		h ₄	in	154.7	154.7	166.5	166.5
	4.7	Height of overhead guard		h ₆	in	74.4	74.4	76.3	76.3
	4.8	Seat height		h ₇	in	33.5	33.5	36.6	36.6
	4.12	Coupling height		h ₁₀	in	27.6	27.6	28.7	28.7
	4.19	Overall length		l ₁		86.5	86.5	100.2	100.2
	4.20	Length including back of forks		l ₂	in	55 ●	55 ●	60.8 ●	60.8 ●
	4.21	Overall width		b ₁	in	31.7	33.5	33.9	35
	4.22	Fork dimensions		s/e/l	in	1.2x3.1x39	1.2x3.1x39	1.4x3.9x39	1.4x3.9x39
	4.23	Forks carriage ISO 2328. Class/form A. B				ISO II/A	ISO II/A	ISO II/A	ISO II/A
	4.24	Forks carriage width		b ₃	in	30.9	30.9	32.7	32.7
	4.31	Floor clearance with load under mast		m ₁	in	2.4	2.4	3.1	3.1
4.32	Floor clearance centre wheelbase		m ₂	in	2.7	2.7	3.6	3.6	
4.34	Right Angle Stack (for a 40" wide by 48" long pallet load)			in	106.5	106.5	112.3	112.3	
4.35	Turning radius		W ₃	in	46.3 ▲	46.3 ▲	51.3 ▲	51.3 ▲	
PERFORMANCE	5.1	Driving speed with/without load		mph	4.7 / 4.8	4.5 / 4.8	5.3 / 5.6	5 / 5.3	
	5.2	Lift speed with/without load		fpm	43.3 / 58.7	41.3 / 58.7	47.2 / 70.9	43.3 / 70.9	
	5.3	Lowering speed with/without load		fpm	78.7 / 68.9	84.6 / 68.9	84.6 / 68.9	88.6 / 68.9	
	5.6	Max. drawbar pull. with/without load		lb	315 / 360	292	697 / 731	697 / 719	
	5.7	Gradeability. with/without load		%	13 / 18	9 / 15	13 / 16	10 / 15	
	5.8	Max Gradeability. with/without load		%	18 / 22	16 / 20	20 / 25	18 / 22	
	5.10	Service brake				hydraulic	hydraulic	hydraulic	hydraulic
ELECTRIC SYSTEM	6.1	Drive motor rating S2 60 min.		kW	2	2	3	3	
	6.2	Lift motor rating at S3 20%		kW	3	3	4.5	4.5	
	6.4	Battery voltage/nominal capacity K5		V/Ah	24/270 - 24/500	24/500	36/270 - 36/500	36/375 - 36/500	
	6.5	Battery weight		lb	584 ■ - 860	860 ■	805 ■ - 1257	1014 ■ - 1257	
OTHER	8.1	Type of drive control			AC MOSFET	AC MOSFET	AC MOSFET	AC MOSFET	
	8.2	working pressure for attachments		psi	2031	2393	2031	2683	
	8.4	Sound pressure level at operator's ear			-	-	-	-	

- ▲ with mast in vertical position
- included side-shift

Non-standard tires, different masts, optional equipment, etc. may result in different values.
Right Angle Stack and Equal Intersecting Aisle dimensions (provided with a 48" long and 40" wide pallet load) allowing zero clearance.



MONTREAL (Head office)
19151 A, Cruickshank Avenue
Baie-D'Urfé (Québec) H9X 3N9
Phone: 418 694-4223
Toll free: 1 866 421-4223
info@elevex.ca | elevex.ca

QUEBEC
1279, Paul-Émile Giroux St. Suite
200 Québec (Québec) G1C 0K9

SAGUENAY
2305, Alexis-Le-Trotteur
St. Jonquière (Québec) G7X 9H8

