



Some of the photos may include optional equipment.

HYUNDAI MATERIAL HANDLING **Applied Tier 4 Engine**

# 15/18/20L-7M

**HYUNDAI**  
MATERIAL HANDLING  
**NO ONE DELIVERS MORE**

 **ELEVEX™**  
Material Handling Solutions

# NEW criteria of Forklift Trucks

Hyundai introduces a new line of 7M series LPG forklift trucks. Excellent power and performance make your business more profitable.



**Operator Presence Sensing System (OPSS)**  
Control of mast tilting, lifting and lowering is not possible through operation of the appropriate control when the not in the seated position.

Some of the photos may include optional equipment.

## The new master on the job-site!

Smooth running, efficient and ergonomically designed, 15/18/20L-7M series are made to meet your needs.

### 37.3kW/ 2,450rpm



#### Powerful Engine L4KB Engine

Market approved quality of L4KB engine ensures incomparable performance, durability and additional value to the machine. Powerful and efficient engine provides excellent fuel economy and excellent torque for improved operation.(EPA/CARB Tier-IV Certified)

#### Fast and Stable Performance

Being able to quickly raise and lower the mast, as well as tilt it forward and backward, provides the best operational conditions during unloading.

When the truck is fully loaded, mast lowering speed is carefully controlled to ensure safety by the down control valve. Mast, Lift and Tilt Lock System is standard.



**High Power  
Low Noise**

Some of the photos may include optional equipment.

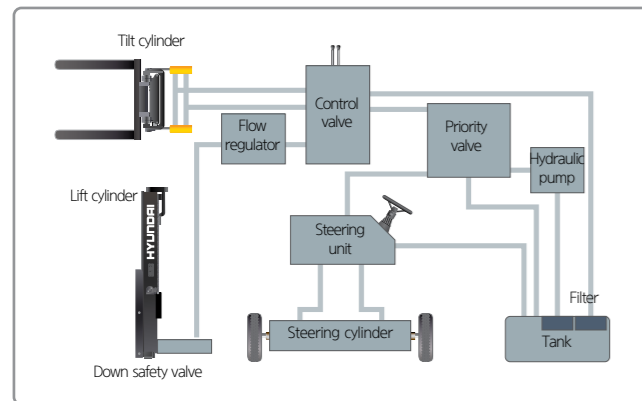

#### State-of-the-art Hydraulic System

The latest large-capacity hydraulic system reacts quickly during operation, and a low-noise control valve increases both efficiency and durability.



#### Fully Hydrostatic Power Steering

A hydraulic steering system always guarantees smooth and flexible steering, preventing overrun and kick-back.



#### Increased Mast Tilting Angle

Utilizing the mast tilting angle of 6 degrees forward and 10 degrees backward, the operator can safely and rapidly perform loading and unloading jobs.

#### Faster Travel Speed & Better Gradability

The powerful high-output engine provides greater acceleration, better gradability and faster travel speed on any tough terrains or slopes.



**Gradability (Loaded)**  
 15L-7M: 39.7% (21.7°)  
 18L-7M: 35.4% (19.5°)  
 20L-7M: 33% (18.3°)

**Travel Speed (Unloaded)**  
 15L-7M: 20.1 km/h  
 18L-7M: 20.1 km/h  
 20L-7M: 20.1 km/h

## Ergonomic operator friendly compartment design!

A design based on human engineering relieves fatigue and increases operator's efficiency.

### Operator Friendly Gauges and Water-resistant Monitor Panel

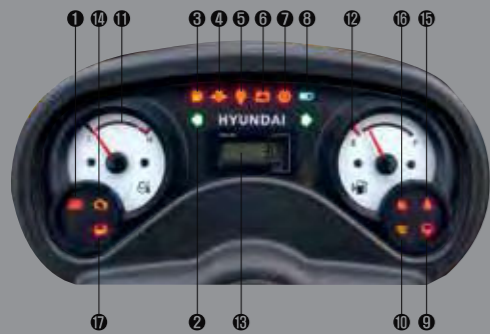

- 1 Parking brake lamp
- 2 Directional indicators
- 3 Fuel warning lamp
- 4 Engine oil warning lamp
- 5 Transmission oil temperature warning lamp
- 6 Battery charging warning lamp
- 7 Air cleaner filter warning light
- 8 Working light indicator
- 9 Water separator lamp
- 10 Pre-heater indicator
- 11 Water temperature gauge
- 12 Fuel gauge
- 13 Hour meter
- 14 Engine check lamp
- 15 Seat belt warning
- 16 OPS warning
- 17 Brake oil warning lamp

### Grammer Seat (Option)



- Quick Achievement of the Ergonomically Best Sitting Position
- Asymmetrical Backrest
- Movable Armrests
- Seat Heating
- Practical Document Box



### New High Visibility for Safe Operation

The operator is able to work with increased safety and accuracy due to a wider view mast.



### Travel Speed Control System (Option)



- ← In-Door : Max. Travel Speed 15~17 km/h
- ← Out Door : Max Travel Speed : Max. Vehicle Speed

Some of the photos may include optional equipment.



### Ergonomically Positioned Pedals

Based on human engineering, the accelerator, brake and inching pedals are optimally positioned for convenience while operating the equipment.



### Cup Holder & Console Box

Additional storage spaces are located inside the operating space for operator's convenience.



### Quick Response of Operating Control Levers

Only minimal operator's effort is required for precise, safe and productive control.



### Adjustable Steering Wheel

Steering wheel with horn button can be adjusted by a lever on the right-hand side for the most comfortable operator position.



### Easy and Safe Shift Lever

A single lever on the left side of the steering column gives the operator fast, easy control of direction. The lever must be in the neutral position before the engine can be started.



### Secondary Horn

Secondary Horn gives access to lights and horn

## Danger-free through high durability!

Safety and durability are priorities in design of the equipment.



### Strong Overhead Guard

The safety overhead guard meets ISO 6055 regulation and protects the operator during hazardous jobs.



### Parking Brake

Ratchet type parking brake requires less effort from the operator to set.



### Highly Durable Split type Drive Axle

The bevel gear set and hub reduction drive axle smoothly delivers desired torque to the drive wheels.



Some of the photos may include optional equipment.



### Large Footboard & Hand Grip

Wide "open" step offers convenience and safety when entering and exiting truck.



### Expansion Bellows

The expansion bellows absorbs vibration and reduces noise generated from the exhaust system and also extends the life cycle of exhaust system.



### Electrically Monitored Air Filter

Air cleaner sensor alerts the operator of a restricted air filter and allows replacement before damage.

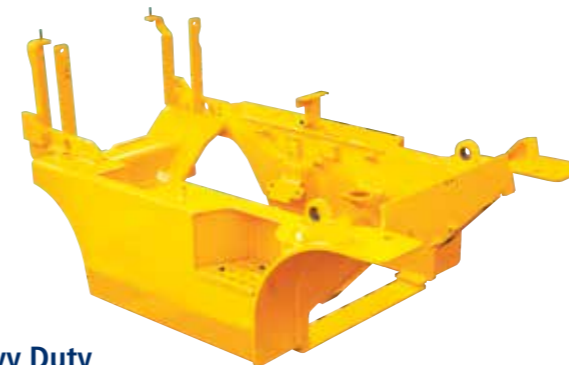

### Heavy Duty Single Unit Frame

Heavy duty single unit type frame, designed on the basis of accurate structural analysis, guarantees durability and safety.



### Bright, Protected Headlights

Bright, Protected head lights are positioned for exceptional visibility.



### Rear Safety Lamp

Rear combination lamps with directional indicators, rear lights and brake lights are positioned for a high level of safety.

# Designed for quick and easy service!

An ideal arrangement of component parts ensures easy access and convenience for maintenance.



### Easy Change Air Cleaner

The air filter is readily accessible for cleaning or replacement. (6inch Cyclone Type)



### Fast Service Access for Daily Fluids Check



Rotational Battery Installation



One Touch, No Tool Floor Plate



Aluminum Radiator with Superb Protection Against Heat



### Improvement in Maintenance of Electric Parts

Various electric parts are centralized in dash board resulting in effortless troubleshooting.



### Easy Maintenance Oil Check

The T/M oil level can be checked easily without any disassembly.



### Brake Fluid Reservoir with level switch

When the brake oil level become lower than Min. level, the warning lamp on the cluster is turned on.



### An Accessible, Compact Fuse Box for Easy Inspection

## Mast Specification

Mast Type	Maximum Fork Height (mm)	Overall Height Lowered (mm)	Tilt Angle (deg)		Free Lift (in)				Load Capacity w / o Integral Side Shift 500mm (kg)			Load Capacity w / Integral Side Shift 500mm (kg)			Truck Weight Unload			
			Fwd	Bwd	With Backrest		With / o Backrest		Single Tire			Single Tire			Single Tire			
					15L/18L-7M	20L-7M	15L/18L-7M	20L-7M	15L-7M	18L-7M	20L-7M	15L-7M	18L-7M	20L-7M	15L-7M	18L-7M	20L-7M	
2-Stage Limited Free Lift	V250	2,525	1,755	6	10	145	150	145	150	1,500	1,750	2,000	1,400	1,650	1,890	2,764	2,938	3,085
	V270	2,725	1,855	6	10	145	150	145	150	1,500	1,750	2,000	1,400	1,650	1,890	2,778	2,952	3,099
	V300	3,025	2,005	6	10	145	150	145	150	1,500	1,750	2,000	1,400	1,650	1,890	2,798	2,972	3,119
	*V330	3,325	2,155	6	10	145	150	145	150	1,500	1,750	2,000	1,400	1,650	1,890	2,818	2,992	3,139
	V350	3,525	2,255	6	10	145	150	145	150	1,500	1,750	2,000	1,400	1,650	1,890	2,832	3,006	3,152
	V370	3,725	2,355	6	10	145	150	145	150	1,500	1,750	1,950	1,400	1,650	1,830	2,845	3,019	3,166
	V400	4,025	2,505	6	10	145	150	145	150	1,450	1,730	1,550	1,360	1,620	1,450	2,870	3,044	3,190
	V450	4,525	2,855	6	6	145	150	145	150	1,370	1,650	1,500	1,280	1,550	1,400	2,936	3,110	3,257
3-Stage Full Free Lift	V500	5,025	3,105	6	6	145	150	145	150	1,300	1,450	1,000	1,210	1,360	930	2,970	3,144	3,290
	V550	5,525	3,355	6	5	145	150	145	150	1,000	950	750	930	880	690	2,990	3,164	3,311
	TF/TS370	3,735	1,805	6	6	798	803	1,299	1,300	1,500	1,750	1,920	1,400	1,650	1,820	2,913	3,087	3,243
	TF/TS400	4,035	1,905	6	6	898	903	1,399	1,400	1,500	1,700	1,870	1,400	1,600	1,770	2,933	3,107	3,263
	TF/TS430	4,335	2,005	6	6	998	1,003	1,499	1,500	1,450	1,700	1,820	1,360	1,600	1,720	2,952	3,126	3,282
	TF/TS450	4,535	2,105	6	6	1,098	1,103	1,599	1,600	1,420	1,630	1,650	1,340	1,540	1,550	2,971	3,145	3,301
	TF/TS470	4,735	2,155	6	6	1,148	1,153	1,649	1,650	1,400	1,450	1,350	1,320	1,360	1,270	2,938	3,157	3,313
	TF/TS500	5,035	2,255	6	6	1,248	1,253	1,749	1,750	1,370	1,400	1,000	1,290	1,320	930	3,002	3,176	3,332
	TF/TS550	5,535	2,455	6	5	1,448	1,453	1,949	1,950	1,050	1,100	750	980	1,030	690	3,040	3,214	3,370
	TF/TS600	6,035	2,655	6	5	1,648	1,653	2,149	2,150	750	750	500	700	700	450	3,112	3,286	3,442
TF/TS650	6,535	2,855	3	3	1,848	1,853	2,349	2,350	500	500	450	450	400	400	3,157	3,331	3,487	
TF/TS700	7,035	3,055	3	3	2,048	2,053	2,549	2,550	350	250	300	300	200	250	3,193	3,367	3,523	

\* TS-Mast : Wide Visible 3 Stage Full Free Lift Mast with 2 Free Lift Cylinders.

\* Standard

## Load Capacity

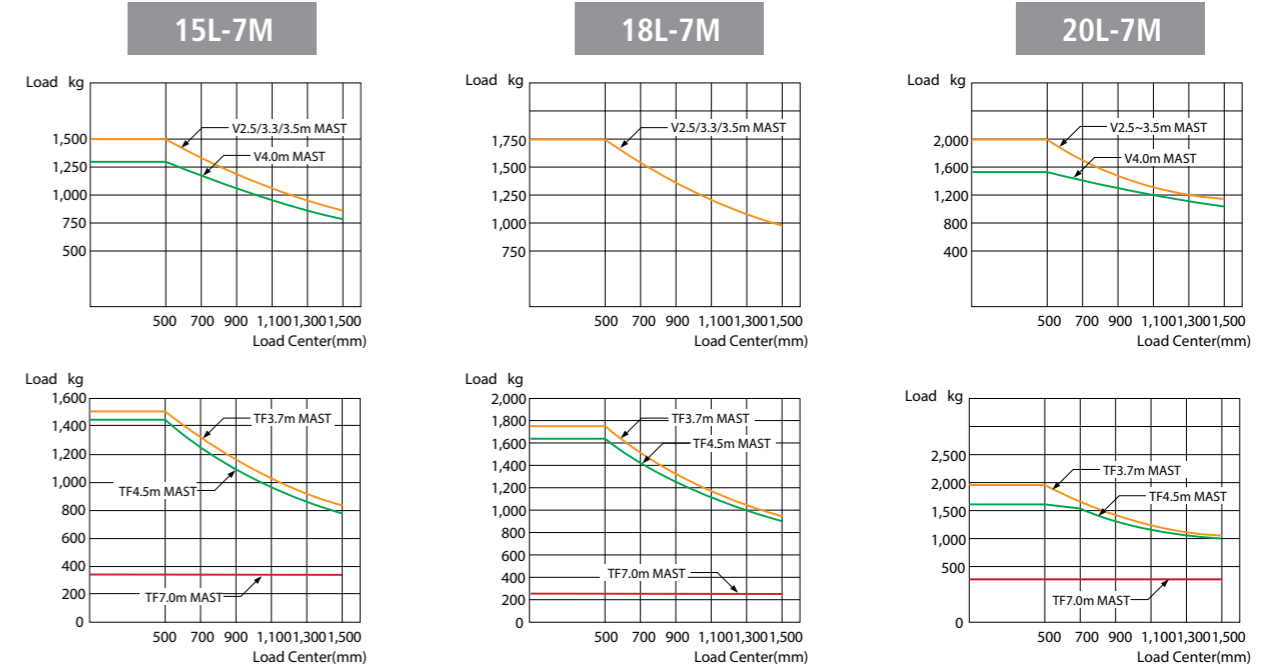

## Optional Items

- SIDE SHIFT
- INTEGRAL SIDE SHIFT
- FORK : 750 / 850 / 1,050 / 1,200 / 1,350 / 1,500mm [15/18L-7M]  
950 / 1,000 / 1,050 / 1,150 / 1,200 / 1,350 / 1,500 / 1,600mm [20L-7M]
- TILTING : 6/5°, 3/3°, 6/6°
- TIRE : Cushion, No-marking
- SEAT : Pocket, Arm Rest, Hip Rest
- LPG CLAMP : Swing Out, Swing Down
- M.C.V : 4-Spool
- ATTACH PIPING : 3 Spool-piping, 4 Spool-piping
- MASTER SWITCH
- BEACON LAMP
- HAZARD SWITCH
- WORK LAMP
- SPEED CONTROL SENSOR

## Dimension

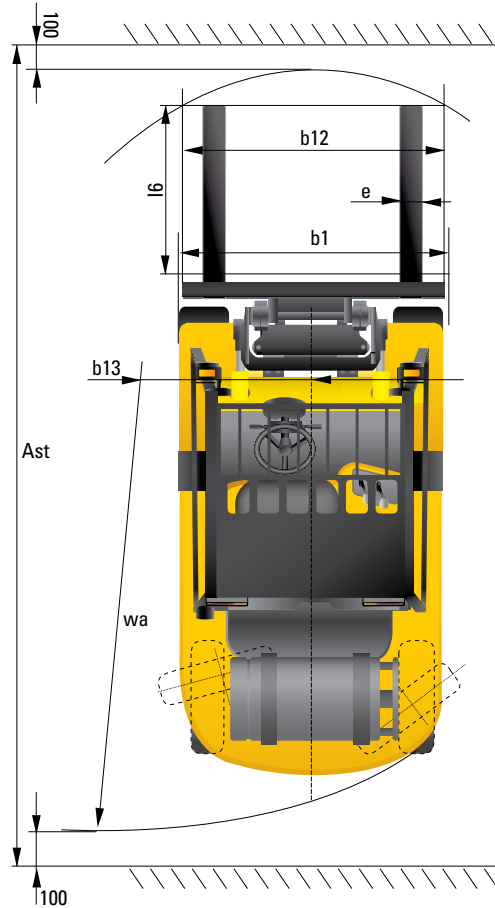
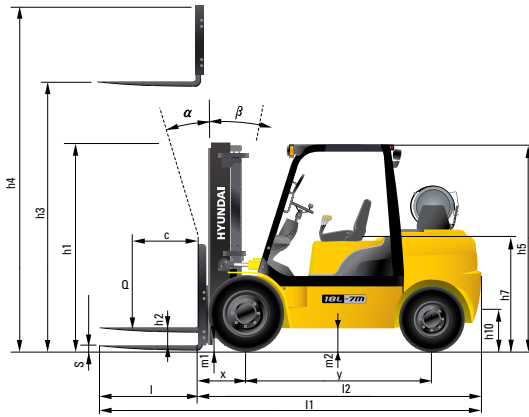

## Specification

Identification			
1.1	Manufacturer	Hyundai	Hyundai
1.2	Manufacturer's type designation	15L-7M	18L-7M
1.3	Drive: electric (battery or mains),diesel,petrol,fuel gas>manual	LP	LP
1.4	Type of operation:hand,pedestrian,standing,seated,order-picker	seated	seated
1.5	Load capacity / rated load	Q (kg)	1,500
1.6	Load center distance	c (mm)	500
1.8	Load distance, center of drive axle to fork	x (mm)	393
1.9	Wheelbase	y (mm)	1,410

Weights			
2.1	Service weight	kg	2,691
2.2	Axle loading, loaded front/rear	kg	3,640 / 550
2.3	Axle loading, unloaded front/rear	kg	1,190 / 1,500

Wheels, Chassis			
3.1	Tires:solid rubber, superplastic, pneumatic,polyurethane	Pneumatic	Pneumatic
3.2	Tires size, front( width x Φ)	6.5 x 10 x 12PR	6.5 x 10 x 12PR
3.3	Tires size, rear( width x Φ)	5.0 x 8 x 10PR	5.0 x 8 x 10PR
3.5	Wheels, number front x rear (x=driven wheels)	2 x 2	2 x 2
3.6	Track width, front	b10 (mm)	890
3.7	Track width, rear	b11 (mm)	910

Basic Dimensions			
4.1	Mast / fork carriage tilt forward / backward( α / β ) degrees	6 / 10	6 / 10
4.2	Lowered mast height	h1 (mm)	2,155
4.3	Free lift	h2 (mm)	145
4.4	Lift height	h3 (mm)	3,325
4.5	Extended mast height	h4 (mm)	4,332
4.7	Overhead load guard (cab) height	h5 (mm)	2,110
4.8	Seat height / standing height	h7 (mm)	1,128
4.12	Coupling height	h10 (mm)	271
4.19	Overall length	l1 (mm)	3,133
4.20	Length to face of forks	l2 (mm)	2,233
4.21	Overall width	b1 (mm)	1,070
4.22	Fork dimensions	l / e / s (mm)	900 x 100 x 35
4.23	Fork carriage ISO 2328, class / type A,B	II / A	II / A
4.24	Fork-carriage width	b12 (mm)	1,004
4.31	Ground clearance, loaded, under mast	m1 (mm)	120
4.32	Ground clearance, centre of wheelbase	m2 (mm)	143
4.34.1	Aisle width for pallets 1000x1200 crossways	Ast (mm)	3,594
4.34.2	Aisle width for pallets 800x1200 lengthways	Ast (mm)	3,794
4.35	Turning radius	Wa (mm)	1,730
4.36	Smallest pivot point distance	b13 (mm)	589

Performance Data			
5.1	Travel speed, Unloaded	km/h	20.1
5.2	Lift speed, Loaded/Unloaded	mm/s	650 / 680
5.3	Lowering speed, Loaded/Unloaded	mm/s	500 / 450
5.6	Max. Drawbar pull, Loaded	N	17,028
5.8	Max. Gradeability, Loaded	%	39.7
5.10	Service brake		Hydraulic

Engine			
7.1	Engine manufacturer / type	HMC / L4KB	HMC / L4KB
7.2	Engine power acc. to ISO 1585	kW/rpm	37.3 / 2,450
7.4	No. of cylinder / Displacement	EA/cc	4 / 2,359

Other Details			
8.1	Type of drive control	Power Shift	Power Shift
8.2	Operating pressure, system / attachments	bar	187 / 147
8.3	Oil volume for attachments	l/min	60
8.4	Sound level at the driver's ear according to DIN 12053	db(A)	80



**MONTREAL (Head office)**  
19151 A, Cruickshank Avenue  
Baie-D'Urfé (Québec) H9X 3N9  
Phone: 418 694-4223  
Toll free: 1 866 421-4223  
[info@elevex.ca](mailto:info@elevex.ca)

**SAGUENAY**  
2305, Alexis-Le-Trotteur  
St. Jonquière (Québec) G7X 9H8  
[elevex.ca](http://elevex.ca)



**NO ONE  
DELIVERS MORE**

**HD HYUNDAI XITESOLUTION MATERIAL HANDLING**