

Hyundai 9 Series Dual Fuel Forklifts

# **25·30G-9A** **35GN-9A**

5,000-7,000 lbs. Capacity · Pneumatic Tire



**NO ONE DELIVERS MORE**

**HYUNDAI**  
MATERIAL HANDLING

**E** **ELEVEX™**  
Material Handling Solutions

# Your satisfaction is our priority.

## New Dual Fuel Forklift with Proven Quality and Advanced Technology

Hyundai introduces a new line of 9 Series Dual Fuel Forklifts. These 4-wheel counterbalanced trucks provide superior operator comfort, increased productivity, added versatility, and easy maintenance.

### High Efficiency

- Tier 4, High power engine : HMC L4KB
- \* LPG : 60.9hp / 44.1kW
- Dual Fuel (gasoline): 60.2hp / 43.7kW
- Reduce inching impact : Clutch protection system
- Wet disc brake

### Advanced Safety

- Auto parking brake system
- Hill Assist Control
- Operator Presence Sensing System
- Machine inclination indication

### Greater Convenience

- 2.5 inch LCD color display
- Auto fork leveling system (OPT)
- Load weight indicator (OPT)
- 4-piece bolt on cabin (OPT)

### Easy Maintenance

- Password starting system
- Consumable item replacement cycle warning
- Rear tire cover & under cover (OPT)



Power & Performance

# Optimal Performance & High Efficiency

The powerful engine and high-tech systems provide you with enhanced performance and superior productivity.

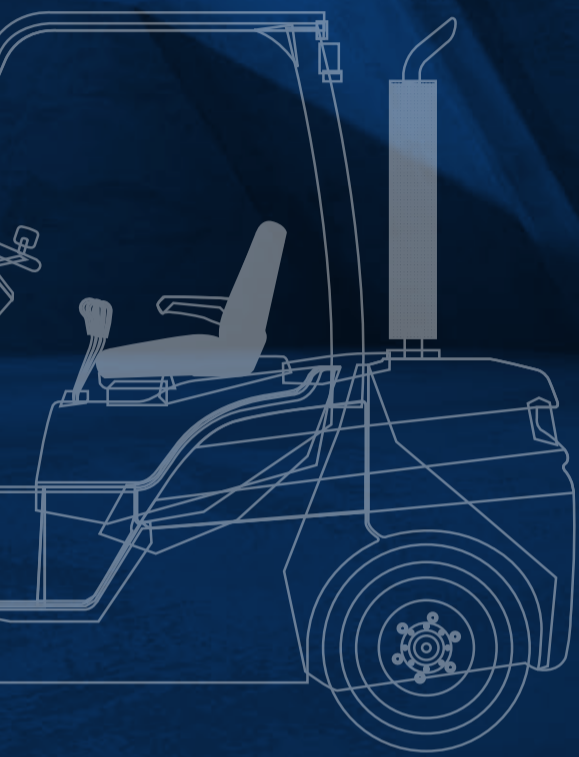

HIGH PERFORMANCE

POWERFUL ENGINE



## Powerful HMC L4KB (2.4L) Engine

The proven HMC L4KB engine delivers exceptional performance, rock solid durability, and added long-term value for a significantly lower cost of ownership.

- **Powerful & Efficient**—Designed to handle demanding workloads while maintaining excellent fuel economy and outstanding torque
- **Trusted Quality**—with proven performance in real-world applications, this powerful workhorse engine sets the standard for reliability
- **Low Emissions**—this Hyundai powerplant is fully compliant with EPA/CARB Tier-IV emission standards, offering both superior output with environmental responsibility

	HMC L4KB	
	LPG	GAS
Rated Power (hp / rpm)	60.9 / 2,300	60.2 / 2,300
Max Torque (lbft / rpm)	137.4 / 1,800	136 / 1,800
Displacement(cc)	2,359	



**Oil-Cooled Wet Disc Brake**

This advanced system delivers outstanding braking power even under heavy loads, 70% longer service life than standard disc brakes, and enhanced durability with an integrated oil cooler.



**Highly Durable Drive Axle**

The reinforced drive axle, separable from the transmission, ensures reduced vibration, smoother performance, and easier maintenance for increased reliability and reduced downtime

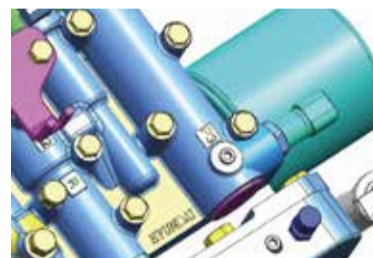

**Clutch Protection System**

A warning lamp activates if the half clutch and accelerator are used simultaneously to prevent improper operation, reduce component wear, extend machine life, and promote better driving habits.



**Fully Hydrostatic Power Steering**

This advanced system delivers smooth and responsive handling, precise control in any condition and prevents overrun and kick-back, to improve maneuverability and enhance operator comfort.

## Faster Travel Speed & Gradeability

The high-output engine delivers exceptional acceleration, superior gradeability, and increased travel speed to conquer tough terrain and steep slopes with ease. Whether it's a demanding jobsite or uneven ground, you get the performance you need to stay ahead.

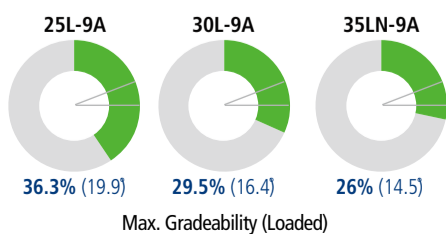

Max. Gradeability (Loaded)

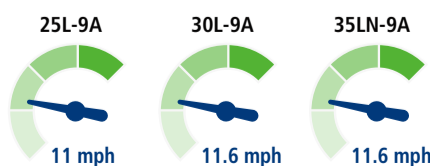

Max. Travel Speed (Unloaded)



**Boosting-Type Brake Valve (OPT)**

Equipped with a boosting-type brake valve, the system delivers powerful and responsive braking performance, ensuring greater control, shorter stopping distances, and increased safety—especially in demanding work environments.



**Dual Fuel System: LPG/Gasoline**

With its **13-gallon gas tank**, the versatile fuel system is designed to support simultaneous use of LPG and gas, offering maximum flexibility on the job. If one fuel source runs out during a shift, the system allows for an instant, seamless switch – no downtime, no refueling delays.

Optimized Ergonomics

# Outstanding Operator Comfort and Convenience

The ergonomically designed workspace combined with a compact, maneuverable build ensures operator comfort, enhanced machine performance, and exceptional productivity. Every detail is engineered to keep your team working smarter, longer, and more efficiently.



## Spacious Operator Cabin

The newly designed operator cabin offers expansive visibility and a spacious, ergonomic environment—delivering all-day comfort and enhanced situational awareness.



### Grammer™ Suspension Seat

The easily adjusted seat, designed with human engineering principles, helps reduce operator fatigue while delivering greater comfort through long shifts. Features include:

- ELR (Emergency Locking Retractor) seatbelt—Provides enhanced safety with secure, responsive restraint
- Standard seat heating—Keeps operators warm and comfortable in colder conditions
- Optional headrest—Adds extra support for greater comfort all day long



### Optimized Pedal Position

Pedals are mounted directly to the console to minimize operator fatigue while also reducing noise and dust intrusion from the engine compartment. The result is a quieter, more comfortable workspace that enhances operator focus and productivity.



### Adjustable Steering Wheel

For optimal driving comfort, the steering column angle can be effortlessly adjusted using a convenient lever located on the right-hand side. This allows operators to quickly find their ideal driving position, reducing fatigue and improving overall control.



### Fingertip Controls (OPT)

The ergonomically designed fingertip control levers are strategically positioned to eliminate excessive reaching and awkward shoulder movement, providing operators with greater comfort, reduced fatigue, and enhanced operational efficiency.

## Advanced LCD Color Monitor

The 2.5-inch wide screen allows the operator to easily control the machine. The monitor features speed, travel direction, battery discharge indicator, hour meter, and more.



### Main Monitoring Features

- Load Weight Indicator (OPT)—Accurately monitors load weight to help prevent overloading and ensure safe operation
- Inclination Warning—A red alert signal activates when unsafe tilt angles are detected
- Signal & Warning Lights—Instantly notify the operator of critical system alerts and operating conditions
- Gear Position Display—Clearly shows Forward, Neutral, Reverse (F/N/R)

#### 1 Load Indicator (OPT)

Displaying real-time load weight, the indicator allows operators to work with greater precision and confidence. Equipped with a highly responsive sensor, the system includes an overload alarm if the load exceeds safe limits to help prevent accidents.

#### 2 Auto Fork Leveling System (OPT)

The Auto Fork Leveling system automatically stops mast tilt movement when the forks return to a perfectly level, straight position to help operators align loads quickly and accurately increasing productivity and reducing handling time—especially during repetitive lifting tasks.

#### 3 Machine Inclination Indication

Built-in grade (left) and slope (right) sensors integrated into the MCU provide real-time feedback on the vehicle's position relative to the road surface. This intelligent system continuously monitors and displays grade and slope status, helping operators navigate challenging terrain safely and efficiently.

Safe & Secure

# Excellent Visibility Advanced Safety

The operator's compartment is designed to bring maximum safety to your drivers, those working around your forklift, and your entire workplace.

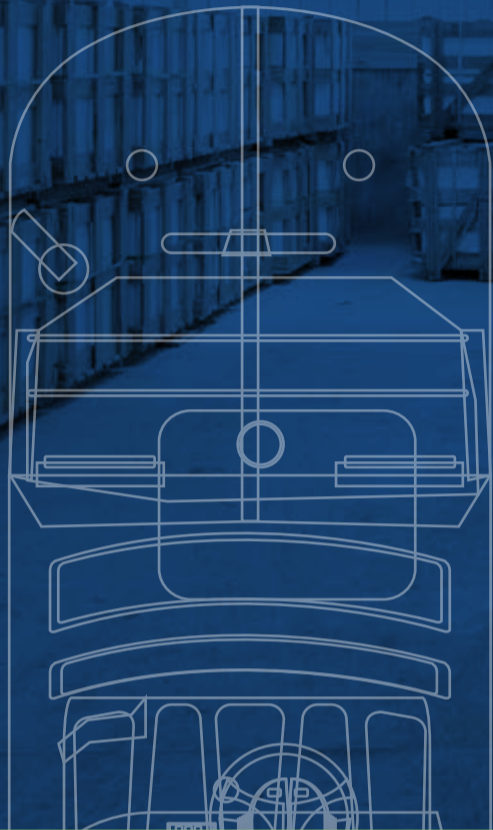

EXCELLENT VISIBILITY

ADVANCED SAFETY

## Excellent Visibility for Safe Operation

The optimized lift cylinder arrangement offers a clearer, wider forward view, improving safety and precision during load handling. The panoramic rearview mirror also expands visibility when reversing, reducing blind spots.



### Safety Lamps & Rear Reflectors

Equipped with halogen headlights and rear LED combination lights, this lighting arrangement ensures clear visibility in all working conditions, enhancing safety and productivity. Rear reflectors mounted on the counterweight further improve visibility, helping to alert others and protect both the operator and surrounding personnel. For even greater visibility and efficiency, a full LED lighting package is available as an option.



### Low Entrance Height

The low entrance height design ensures quick, easy, and safe access for operators. This also reduces strain and allows faster transitions on and off the machine, especially during frequent entry and exit.

## Key Safety Systems

Equipped with a high-sensitivity sensor and an intelligent safety system, the 9 Series is designed to proactively detect and respond to potential hazards, helping to eliminate the risk of accidents. It's a smarter, safer solution that protects both operators and your investment.

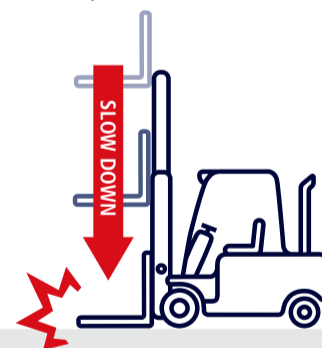

### Fork Safety Features

During lowering, a down-control valve ensures the forks descend smoothly and at a controlled speed, enhancing precision and safety. In the event of a hydraulic line failure, the down-safety valve immediately activates to prevent sudden fork drop.



### Auto Parking Brake

When the engine shuts off or the Operator Presence Sensing System (OPSS) activates, the parking brake engages automatically, helping to prevent accidental movement and eliminate human error. For added flexibility, operators can also manually apply or release the brake at any time while the engine is running using a dedicated control button.

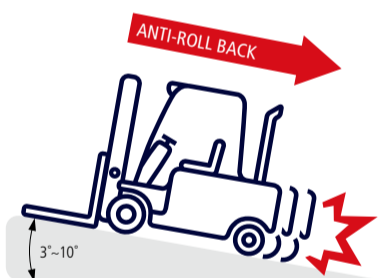

### Hill Assist Control (HAC)

This feature prevents unintended movement while operating the forklift on a grade, incline or decline, giving the operator greater confidence and increasing safety on the job. Combined with exceptional ramp start capabilities, it delivers smooth, controlled performance on even steep grades.

### DRIVE LOCK LIFT LOCK TILT LOCK



### Operator Presence Sensing System

All mast and drive movements stop functioning when the operator is not in the seat.



### Strong Overhead Guard

Built to exceed CEE and ANSI regulations, the robust overhead guard provides maximum protection without compromising visibility. Its smart design ensures clear, all-around sightlines, enhancing safety and efficiency.

Maintenance & Convenience

# Fast, Easy Maintenance Cuts Downtime

The intelligent design of the 9 Series simplifies routine maintenance and daily inspections. You'll find convenience advantages throughout the machine to increase your productivity and profits.

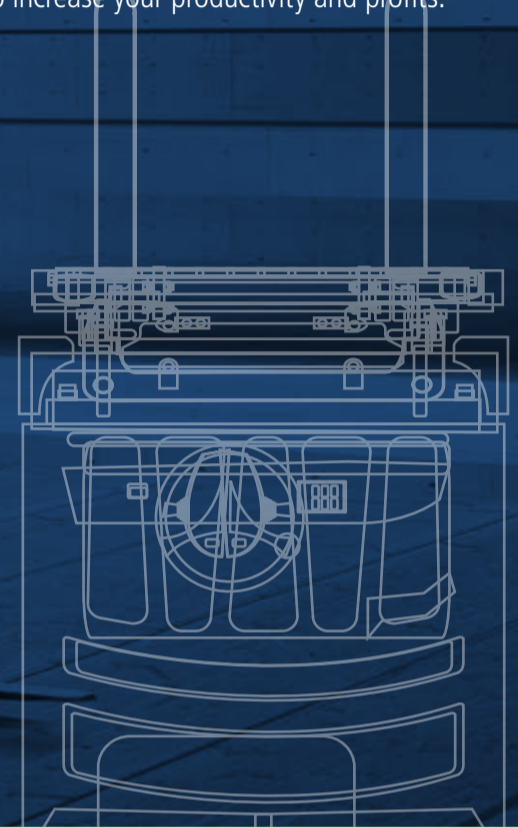

## Large, Highly Accessible Engine Compartment

This design allows quick, hassle-free maintenance, reducing downtime. The enlarged 7" air cleaner also prolongs engine service life with enhanced filtration and extended service intervals. All for greater reliability in even the toughest conditions.



Waterproof & Dustproof Cover

The new waterproof and dustproof fuse and relay boxes are designed to withstand harsh working conditions while ensuring easy access for maintenance. This added protection helps to prevent electrical issues and reduce downtime.



Rear Tire & Under Cover (OPT)

These protective features help extend component life and reduce maintenance needs. For added flexibility, each cover can be selected separately to match your operational requirements.

### Active Fault

DTC	SPN	FMI
0141	110	4

Engine Coolant Temperature Sensor voltage too Low

#### Engine Failure Control

The system allows operators and technicians to instantly view engine failure codes directly on the cluster screen, thanks to real-time monitoring by the ECU. No additional tools are required—making troubleshooting faster, more precise, and minimizing machine downtime for maximum productivity.



#### Parking Brake Switch (STD) & Emergency Switch (OPT)

These two convenient switches help operators avoid and respond to emergency situations. The button-type emergency switch allows operators to quickly signal emergency situations ensuring fast response times. Both switches enhance safety and give operators peace of mind on the job.

### Engine oil & filt..

Cycle 500

Elaps. Time 174

History 0

#### Automatic Maintenance Indicator

This indicator automatically alerts the operator of the replacement cycle of key consumable items before a failure occurs; making managing maintenance easy, and to help extend the life of the machine.

### Enter user pass..



#### Password Starting System

By granting the operation authority only to the designated driver, it is possible to manage the vehicle and prevent theft.



## THE 9 SERIES COMES WITH OUR BEST-IN-CLASS WARRANTY

When you build better equipment, you can back them better. That's why Hyundai forklifts come with a 3-year, 4,000-hour warranty that sets a new standard for overall lowest cost of ownership.

# HiMATE





ONLY HYUNDAI OFFERS YOU SUCH A COMPREHENSIVE, FULLY INTEGRATED TELEMATICS SYSTEM.



## HI-MATE MANAGEMENT SYSTEM

Hi-Mate is one of the industry's most advanced remote management system. With continuous data collection, Hi-Mate delivers more communication, control, and ability to track, monitor, maintain, and manage your forklift fleet. It is the proven way to efficiently coordinate both your equipment and human resources.

Hi-Mate works by collecting key data from sensors mounted to your equipment that track operation of the forklift, relaying that information to your computer or mobile device in real time. By monitoring key components, such as the engine, electric system, and hydraulics, Hi-Mate can help you evaluate machine and operator performance, create preventive maintenance programs, and help you minimize downtime as you maximize productivity.

 <b>Equipment operation management</b>	 <b>Equipment status management</b>	 <b>Safe traveling control</b>	 <b>Human resource management</b>
<p>Real-time monitoring and follow-up management of individual pieces of equipment or equipment fleet deliver essential operational status and information, including:</p> <ul style="list-style-type: none"> <li>• Key-on time, travel hours, work hours, and GPS location</li> </ul>	<p>Vital diagnostic and maintenance data is relayed as alerts, while Hi-Mate Premium provides tracking of pre-shift checklists to help reduce downtime and ensure OSHA compliance:</p> <ul style="list-style-type: none"> <li>• Alerts are sent for DTCs, system warning, and required maintenance</li> </ul>	<p>An impact monitor provides alerts, accountability, and follow-up management of safety incidents involving equipment during operation:</p> <ul style="list-style-type: none"> <li>• The system logs the number and severity of impacts as well as the operator who was logged into the unit at the time of the incident</li> </ul>	<p>Hi-Mate Premium can control who operates equipment via a pin pad and RFID reader:</p> <ul style="list-style-type: none"> <li>• Provided information can be used to evaluate productivity, efficiency, and workforce safety</li> <li>• Tracking the weight load indicator captures operator productivity</li> </ul>

## Data Flow

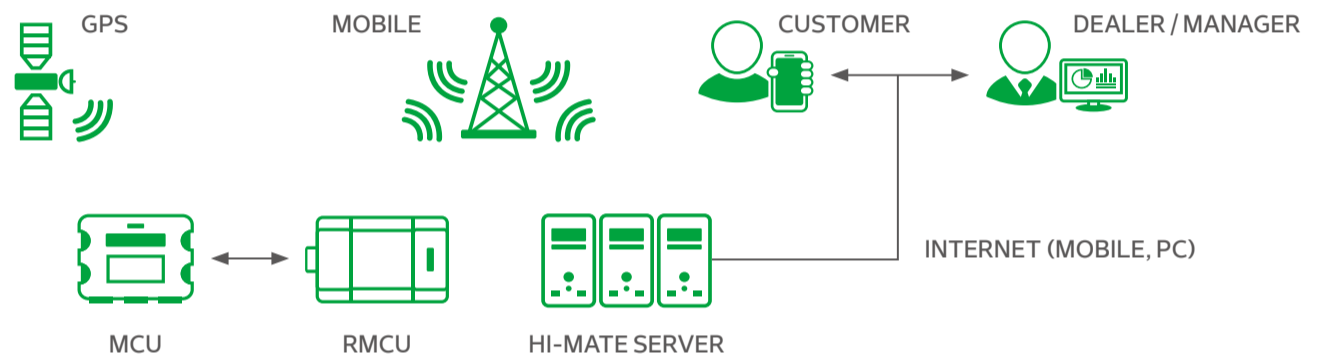

## New 9 Series Mast Specifications

### 25G-9A

Mast Type	Maximum Fork Height	Overall Height (Lowered)	Free Lift Height		Tilt Angle		Load Capacity without side shift		Load Capacity with side shift		Truck Weight (Unloaded)		
			With Load Backrest	Without Load Backrest	Fwd	Bwd	Single Tire	Double Tire	Single Tire	Double Tire	Single Tire	Double Tire	
			in	in	deg	deg	24 in LC	24 in LC	24 in LC	24 in LC	lb	lb	
2-STAGE LIMITED FREE LIFT	V300	118	80	5	5	6	10	5,000	5,000	5,000	5,000	8,161	8,488
	*V330	130	86	5	5	6	10	5,000	5,000	5,000	5,000	8,203	8,532
	V350	138	90	5	5	6	10	5,000	5,000	5,000	5,000	8,241	8,569
	V370	146	96	5	5	6	10	5,000	5,000	5,000	5,000	8,267	8,598
	V400	158	101	5	5	6	10	5,000	5,000	5,000	5,000	8,355	8,684
	V450	177	113	5	5	6	6	5,000	5,000	4,870	5,000	8,519	8,847
2-STAGE FULL FREE LIFT	VF325/VS325	129	85	39	60	6	6	5,000	5,000	5,000	5,000	8,278	8,618
3-STAGE FULL FREE LIFT	TF430/TS430	170	80	33	54	6	6	5,000	5,000	5,000	5,000	8,496	8,836
	TF450/TS450	177	84	37	58	6	6	5,000	5,000	4,850	5,000	8,545	8,884
	TF470/TS470	185	86	39	60	6	6	4,920	5,000	4,700	4,860	8,576	8,913
	TF500/TS500	197	90	43	64	6	6	4,810	4,940	4,590	4,720	8,624	8,962
	TF550/TS550	217	97	51	72	6	6	3,240	4,780	3,020	4,560	8,710	9,048
	TF600/TS600	236	105	59	80	6	6	2,930	4,590	2,710	4,370	8,854	9,191
	TF650	256	113	67	88	3	3	2,840	4,540	2,620	4,320	8,955	9,295
	TF700	276	121	75	96	3	3	2,430	4,370	2,210	4,150	9,039	9,378
4-STAGE FULL FREE LIFT	QF610	241	85	39	60	3	3	3,200	4,240	2,940	4,000	9,387	9,771
	QF700	276	97	50	71	3	3	2,200	3,960	2,000	3,720	9,586	9,969

\*Standard

# New 9 Series Mast Specifications

## 30G-9A

Mast Type		Maximum Fork Height	Overall Height (Lowered)	Free Lift Height		Tilt Angle		Load Capacity without side shift		Load Capacity with side shift		Truck Weight (Unloaded)	
				With Load Backrest	Without Load Backrest	Fwd	Bwd	Single Tire	Double Tire	Single Tire	Double Tire	Single Tire	Double Tire
								24 in LC	24 in LC	24 in LC	24 in LC		
		in	in	in	in	deg	deg	lb	lb	lb	lb	lb	lb
2-STAGE LIMITED FREE LIFT	V300	118	80	5	5	6	10	6,000	6,000	6,000	6,000	9,030	9,303
	*V330	130	86	5	5	6	10	6,000	6,000	6,000	6,000	9,074	9,347
	V350	138	90	5	5	6	10	6,000	6,000	6,000	6,000	9,114	9,387
	V370	146	96	5	5	6	10	6,000	6,000	6,000	6,000	9,142	9,416
	V400	158	102	5	5	6	6	6,000	6,000	6,000	6,000	9,231	9,506
	V450	177	114	5	5	6	6	6,000	6,000	5,800	6,000	9,398	9,672
2-STAGE FULL FREE LIFT	VF325/VS325	129	85	39	60	6	6	6,000	6,000	6,000	6,000	9,250	9,522
3-STAGE FULL FREE LIFT	TF430/TS430	170	80	34	52	6	6	6,000	6,000	5,810	6,000	9,517	9,786
	TF450/TS450	177	84	38	56	6	6	5,930	6,000	5,630	5,830	9,572	9,843
	TF470/TS470	185	86	40	58	6	6	5,890	5,970	5,590	5,670	9,603	9,874
	TF500/TS500	197	90	44	62	6	6	5,730	5,840	5,430	5,540	9,654	9,923
	TF550/TS550	217	98	52	69	6	6	3,660	5,640	3,360	5,340	9,751	10,020
	TF600/TS600	236	106	59	77	6	3	3,020	5,450	2,720	5,150	9,905	10,174
	TF650	256	114	67	85	3	3	2,930	5,380	2,630	5,080	10,018	10,287
	TF700	276	122	75	93	3	3	2,540	5,200	2,240	4,900	10,112	10,384
4-STAGE FULL FREE LIFT	QF610	241	86	39	57	3	3	3,400	5,120	3,100	4,760	10,317	10,628
	QF700	276	97	51	69	3	3	2,400	4,800	2,160	4,440	10,516	10,827

\*Standard

## New 9 Series

## 35GN-9A

Mast Type		Maximum Fork Height	Overall Height (Lowered)	Free Lift Height		Tilt Angle		Load Capacity without side shift		Load Capacity with side shift		Truck Weight (Unloaded)	
				With Load Backrest	Without Load Backrest	Fwd	Bwd	Single Tire	Double Tire	Single Tire	Double Tire	Single Tire	Double Tire
								24 in LC	24 in LC	24 in LC	24 in LC		
		in	in	in	in	deg	deg	lb	lb	lb	lb	lb	lb
2-STAGE LIMITED FREE LIFT	V300	118	83	5	5	6	10	7,000	7,000	7,000	7,000	9,946	10,129
	*V330	130	89	5	5	6	10	7,000	7,000	7,000	7,000	9,998	10,181
	V350	138	93	5	5	6	10	7,000	7,000	7,000	7,000	10,033	10,216
	V370	146	99	5	5	6	10	7,000	7,000	6,890	7,000	10,085	10,268
	V400	158	105	5	5	6	10	7,000	7,000	6,730	6,860	10,156	10,339
	V450	177	117	5	5	6	6	6,850	7,000	6,470	6,620	10,326	10,509
2-STAGE FULL FREE LIFT	VF325/VS325	129	89	42	60	6	6	7,000	7,000	7,000	7,000	10,207	10,383
3-STAGE FULL FREE LIFT	TF430/TS430	170	83	37	52	6	6	6,820	7,000	6,460	6,600	10,538	10,714
	TF450/TS450	177	87	41	56	6	6	6,710	6,890	6,380	6,510	10,586	10,762
	TF470/TS470	185	89	43	58	6	6	6,620	6,800	6,290	6,420	10,615	10,792
	TF500/TS500	197	93	47	62	6	6	6,490	6,670	6,160	6,290	10,665	10,842
	TF550/TS550	217	101	54	69	6	6	4,820	6,450	4,490	6,070	10,762	10,938
	TF600/TS600	236	109	62	77	6	6	3,100	6,230	2,810	5,870	10,921	11,098
	TF650	256	117	70	85	3	3	2,860	6,000	2,570	5,670	11,029	11,205
	TF700	276	124	78	93	3	3	2,570	5,800	2,280	5,500	11,118	11,294
4-STAGE FULL FREE LIFT	QF610	241	88	41	57	3	3	3,800	5,900	3,480	5,540	11,200	11,388
	QF700	276	99	53	69	3	3	2,800	5,560	2,540	5,200	11,398	11,586

\*Standard

# New 9 Series

## Load Capacity

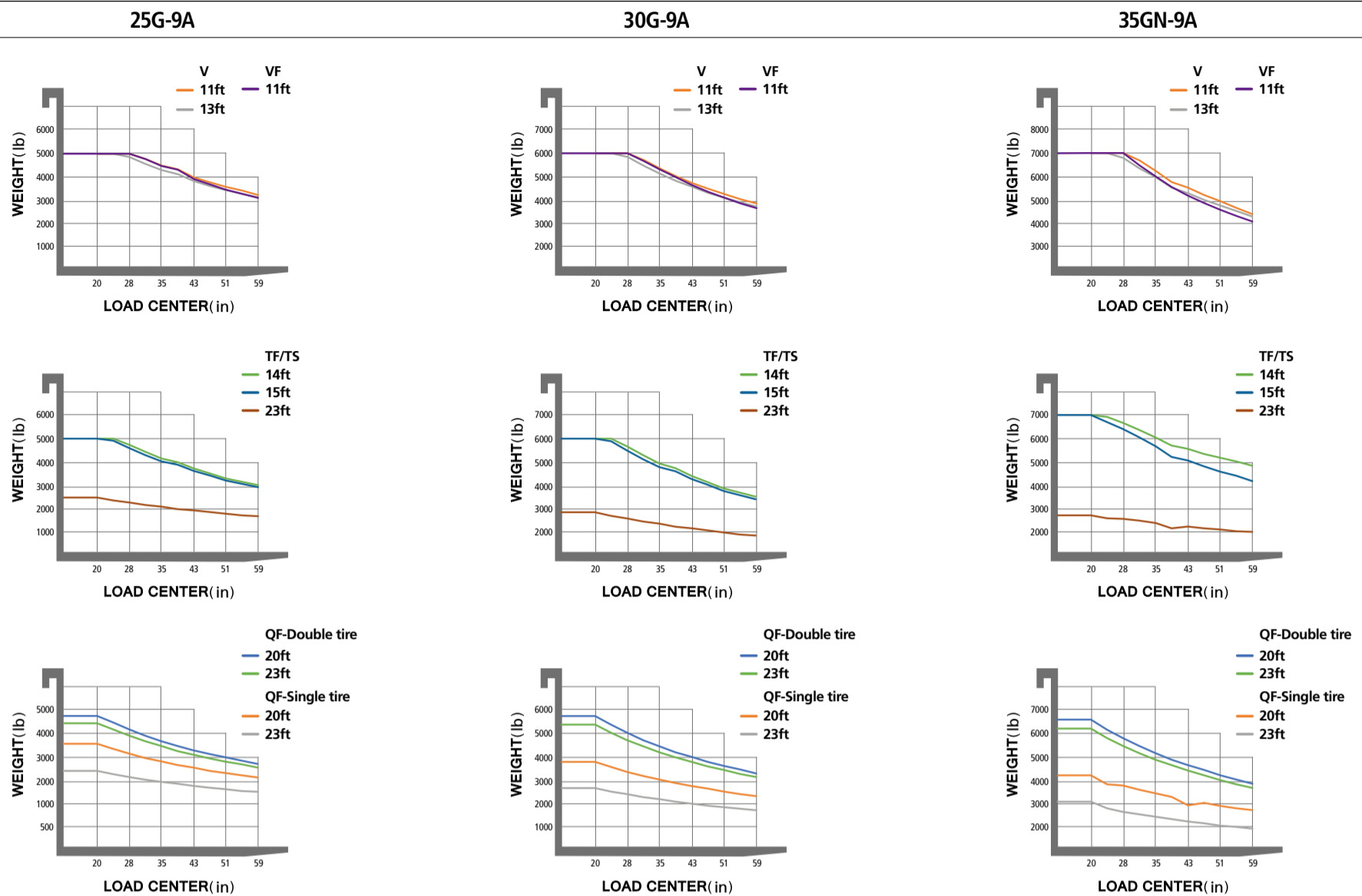

## New 9 Series

## Specifications

Identification						
1.1	Manufacturer	Hyundai				
1.2	Manufacturer's model designation	25L-9A / 25G-9A	30L-9A / 30G-9A	35LN-9A / 35GN-9A		
1.3	Drive: electric (battery or mains), diesel, gasoline, LPG, manual	LPG / GAS	LPG / GAS	LPG / GAS		
1.4	Type of operation: hand, pedestrian, standing, seated, order-picker	seated	seated	seated		
1.5	Load capacity / Rated load	lb 5,000	6,000	7,000		
1.6	Load center distance	c (in) 24	24	24		
1.8	Load distance, center of drive axle to fork	x (in) 18.42516	18.42516	18.42516		
1.9	Wheelbase	y (in) 65	67	67		
Weights						
2.1	Service weight	lb 8,203.4	9,074	9,998		
2.2	Axle loading, loaded front / rear	lb 12,106 / 1,612	13,885 / 18,034	15,305 / 2,409		
2.3	Axle loading, unloaded front / rear	lb 3,306 / 4,844	3,505 / 5,569	3,195 / 6,802		
Wheels, Chassis						
3.1	Tires ; Pneumatic (P), Solid (S), Non-marking (N)	P	P	P		
3.2	Tires size, front	Single	7.00-12-12PR	8.15-15-14PR	8.15-15-14PR	
		Double	6.00-15-10PR	6.00-15-10PR	6.00-15-10PR	
3.3	Tires size, rear	Single	6.50-10-12PR	6.50-10-12PR	6.50-10-12PR	
		Double	6.50-10-12PR	6.50-10-12PR	6.50-10-12PR	
3.4	Number of wheels front / rear (x=driven wheels)	2x / 2	2x / 2	2x / 2		
3.5	Tires width, front	Single (in)	39.3	39.6	39.6	
		Double (in)	45.4	45.4	45.4	
		in	38.6	38.6	38.6	
4.1-4.36	Basic Dimensions					
	Mast/fork carriage tilt forward/backward ( / )	degrees	6/10	6/10	6/10	
	Lowered mast height	h1 (in)	85.62975	86.2203	88.9762	
	Free lift	h2 (in)	6.10235	6.10235	6.10235	
	Lift height	h3 (in)	130.11785	130.11785	130.11785	
	Extended mast height	h4 (in)	176.57445	176.57445	176.57445	
	Overhead guard height (cabin)	h5 (in)	85.0 (85.4)	85.8 (86.2)	85.8 (86.2)	
	Seat height / standing height rel. to SIP	h7 (in)	46.73219	47.71644	47.71644	
	Coupling height	h10 (in)	12.2	12	12	
	Overall length	l1 (in)	143.97609	146.69262	148.89734	
	Length to face of forks	l2 (in)	102.6	105	109	
	4.21	Overall width	Single b1 (in)	47.2	48.4	48.4
			Double b1 (in)	60	60	60
	4.22	Fork dimensions (hook type)	l / e / s (in)	1.8 x 3.9 x 41.3	1.8 x 4.8 x 41.3	1.8 x 4.8 x 41.3
	4.23	Fork carriage ISO 2328, class / type A,B	b3 (in)	2A	3A	3A
	4.24	Fork-carriage width	m1 (in)	43.38574	43.38574	43.38574
	4.31	Ground clearance, loaded, under mast	m2 (in)	5.1181	5.70865	5.70865
	4.32	Ground clearance, center of wheelbase	Ast (in)	6.7	7	6.7
	4.34.1	Aisle width for pallets 39.3x47.24 crosswise	Ast (in)	157.9	160.7	163.7
	4.34.2	Aisle width for pallets 31.5x47.24 crosswise	Wa (in)	165.7	168.5	171.6
4.35	Turning radius	b13 (in)	92.2	95.0	98.0	
4.36	Smallest pivot point distance	b13 (in)	28.1	28.8	28.8	

Performance Data					
5.1	Travel speed, loaded / unloaded	mph	10.2 / 11.0 *(10.1 / 10.8)	10.6 / 11.6 *(10.9 / 11.4)	10.4 / 11.6 *(10.7 / 11.4)
5.2	Lift speed, loaded / unloaded	ft/min	106 / 108	104 / 108	85 / 91
5.3	Lowering speed, loaded / unloaded	ft/min	99 / 89	99 / 89	99 / 89
5.6	Max. drawbar pull, loaded / unloaded	lb	5,226 / 4,963 *(5,667 / 5,375)	4,963 / 4,674 *(5,174 / 5,051)	4,986 / 4,648 *(5,167 / 5,029)
5.8	Max. Gradeability, loaded	%	36.3 / 21.7 *(39.8 / 21.7)	29.5 / 20.6 *(30.9 / 20.6)	26.0 / 18.8 *(27.1 / 18.8)
5.10	Service brake		Hydraulic	Hydraulic	FOOT
Engine					
7.1	Engine manufacturer / type		HMC / L4KB	HMC / L4KB	HMC / L4KB
7.2	Engine power acc. to ISO 1585	hp/rpm	60.9 / 2,300 *(60.2 / 2,300)	60.9 / 2,300 *(60.2 / 2,300)	60.9 / 2,300 *(60.2 / 2,300)
7.3	Maximum Torque	lbft/rpm	137.4 / 1,800 *(136 / 1,800)	137.4 / 1,800 *(136 / 1,800)	137.4 / 1,800 *(136 / 1,800)
7.4	No. of cylinder / cubic capacity	EA/cc	4 / 2,359	4 / 2,359	4 / 2,359
7.5	Fuel consumption acc. to VDI cycle	ℓ/h	4.3	4.5	5.1
Other Details					
8.1	Type of drive control		Power Shift	Power Shift	Power Shift
8.2	Operating pressure, system / attach	psi	2,850 / 2,350	3,150 / 2,350	3,150 / 2,350
8.3	Oil volume (hydraulic)	GPM-US	8 (16 Max.)	8 (16 Max.)	8 (16 Max.)
8.4	Sound pressure level (at driver's ear according to DIN 12053)	dB (A)	80	80	80
8.5	Trailer coupling, type DIN		PIN	PIN	PIN

\*(Dual fuel/Gas)

## Dimensions

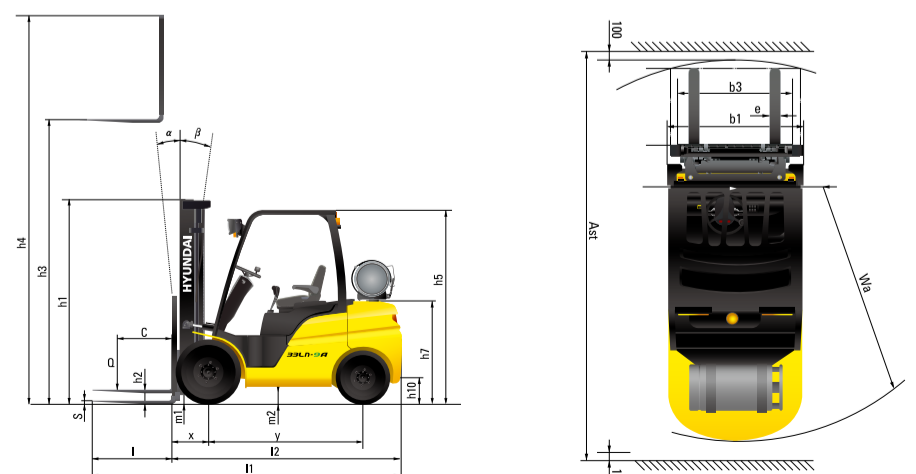

\* All specifications in this catalog are subject to change according to the optional items.

# New 9 Series

## Standard & Optional Features

			25G-9A	30G-9A	35GN-9A				25G-9A	30G-9A	35GN-9A
Operation	OHG	Overhead Guard	●	●	●	Hydraulics	MCV	3 Spool	○	○	○
		Cabin	○	○	○			4 Spool	○	○	○
	A/C	Air Conditioner	○	○	○	Frame	Frame	Under Cover	○	○	○
		Heater	○	○	○			Under Cover + Tire Cover	○	○	○
	Seat	Grammer™ Seat + Belt + Armrest	●	●	●	LPG Tank Bracket	LPG Tank Bracket	Fixed Bracket	●	●	●
		Grammer™ Seat + Various options	○	○	○			Swing Out Bracket	○	○	○
	etc.	Rear Horn with Handle	○	○	○			Swing Down Bracket	○	○	○
		Manual Lever	●	●	●			Fixed Bracket (One-Band)	○	○	○
Lever	Fingertip Control Lever	○	○	○	Swing Out Bracket (One-Band)			○	○	○	
	Cleaner	Pre-cleaner	○	○	○	Tires	-	Pneumatic	●	●	●
Mast & Attachment	Carriage	Carriage – Hook	○	○	○			Solid	○	○	○
		Carriage – Integral	○	○	○			Non Marking	○	○	○
		Narrow	○	○	○			Pneumatic / Solid	○	○	○
		Wide	○	○	○	Lamp	Lamp	LED Working Lamp – Front & Rear	●	●	●
Backrest	Backrest	○	○	○	LED Working Lamp – Front			○	○	○	
Mast	Standard Mast	V330	V330	V330	Mirror	Mirror	Panorama	●	●	●	
	2, 3, 4 Stage Mast	○	○	○			L/H & R/H Back + Panorama	○	○	○	
Fork	41.3"	-	●	●	Convenience	-	Auto Tilt	○	○	○	
	Various Option Fork - 47" ~ 82.7"	○	○	○			Knob Switch with Directional button & Horn	○	○	○	
Attachment	Side Shift	○	○	○			Accumulator	○	○	○	
	Side Shift with Fork Positioner	○	○	○			Load Sensor	○	○	○	

## New 9 Series

		25G-9A	30G-9A	35GN-9A	
Safety	-	Seatbelt Interlock	○	○	○
		LED Beacon Lamp	○	○	○
		Camera (Rear)	○	○	○
		Extinguisher	○	○	○
		Redzone	○	○	○
		Blue Spot (Front / Rear)	○	○	○
		Blue Spot (Front / Rear) + Red Zone	○	○	○
		OPSS - Travel & Mast	○	○	○
		Speed Control	○	○	○
Additional Features	-	Hi-MATE	○	○	○
		Radiator Screen (Wire Net)	○	○	○
		Master Switch to cut off electricity from battery	○	○	○
		Brake - Booster	○	○	○
		OHG Rain cover	○	○	○
		Side – Plastic	○	○	○
		Side – Steel	○	○	○
		HYD Oil VG46	●	●	●
		VG68 for Tropical	○	○	○
VG15 for Cold Area	○	○	○		



**MONTREAL (Head office)**  
19151 A, Cruickshank Avenue  
Baie-D'Urfé (Québec) H9X 3N9  
Phone: 418 694-4223  
Toll free: 1 866 421-4223  
[info@elevex.ca](mailto:info@elevex.ca)

**SAGUENAY**  
2305, Alexis-Le-Trotteur  
St. Jonquière (Québec) G7X 9H8  
  
[elevex.ca](http://elevex.ca)



**NO ONE  
DELIVERS MORE**

