



Internal Combustion Engine Counterbalance Truck

H35 - H50

7,500 - 11,000 lb. Capacity

Series 1204

- Hydrostatic drive, double pedal control, and Linde Load Control for efficient load handling
- Robust design and maintenance-free components guarantee high vehicle availability and low operating costs
- Asymmetric slim mast profiles, narrow A-pillar, lowered front plate and large glass roof panel for excellent visibility
- Wireless data transmission for smooth integration in software systems, e.g. for fleet management
- The vehicle's low center of gravity and intelligent assistance systems reduce the risk of tipping and accidents

STANDARD & OPTIONAL EQUIPMENT

STANDARD

- Vibration-isolated cab
- Tilttable steering column
- Full suspension, weight adjustable seat
- 3.5" color display
- Linde Hydrostatic Drive
- Doosan D24 diesel engine / P24 LPG engine
- Dual engine Air Filter
- LEPS, Linde Engine Protection System
- Variable displacement hydraulic pump
- Solid pneumatic tires (SE)
- High mounted tilt cylinders
- Slanted mast rails
- Tilt cylinders with cushioned end stops
- 6-Rollers with all Carriages
- Dual pedal travel control
- Automatic parking brake (when engine is off)
- Standard tilt range 5° forward/5° backward with standard and duplex masts
- 95" Standard OHG with H35/600 and H40/600
- 96" Standard OHG with H45/600, H50 and H50/600
- Two front work lights (LED)
- 48 month / 8,000 hour warranty

OPTIONAL

- Tire selection: single, dual, non-marking, pneumatic
- Anti load-spray mud flaps
- Several travel speed reductions
- Tilt angle pre-selection
- Fork above ground stop
- Simple, dual, and triplex masts
- 8-roller carriages
- Integrated side shifter
- Integrated sideshifting fork positioner
- Load backrest
- Low-profile overhead guard (87"/88")
- Fully enclosed operator cabin with standard top glass
- Fully enclosed operator cabin with armored top glass
- Configurable half cab
- Seating options: heated, cloth, ventilated
- Swiveling seats, 10 & 17 degrees
- Seat belt interlock
- Air-conditioned & heated cabin
- Internal and external mirrors
- 4-function and 5-function hydraulic valves
- 3rd, 4th and 5th function reeving
- Halogen or LED road light packages
- Front and rear LED stripe lights
- Linde BlueSpot™
- Load weight indicator
- Back-up alarm
- Flashing beacon
- Camera system, front and back
- 7" multifunction color display

FEATURES

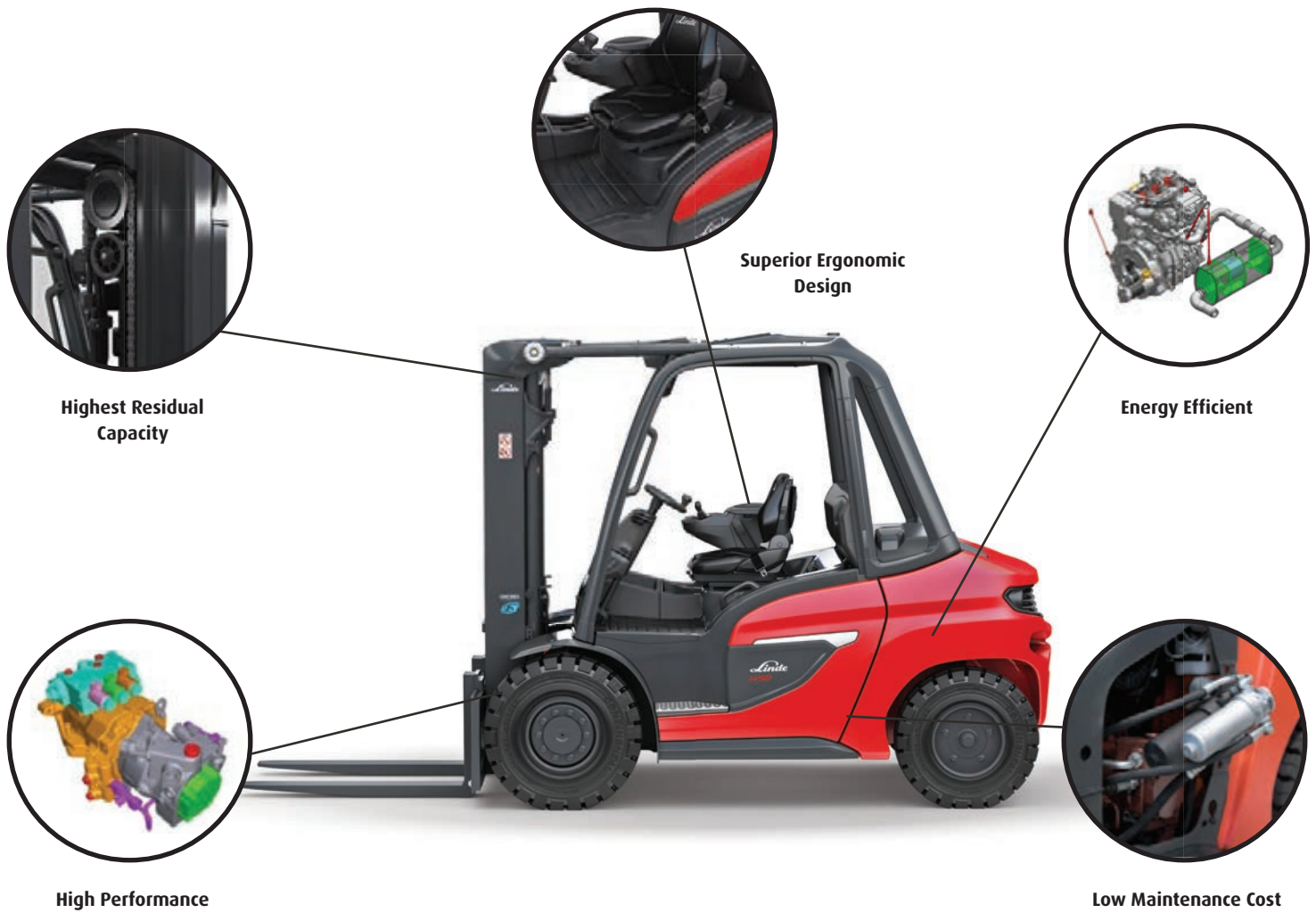

Linde Series 1204 Five Features

Lowest Maintenance Cost:

- 1,000 hour periodic maintenance
- No service brake maintenance or repair
- Neoprene tilt cylinder and axle bearings
- Linde engine protection system (LEPS)

Highest Residual Capacity:

- High rigidity mast rails
- Low center of gravity
- Best weight distribution
- Overhead tilt cylinders

Superior Ergonomic Design:

- Low noise level
- Large foot room
- Standard armrest with fingertip controls
- Standard fully adjustable suspension seat
- Best all-around visibility (shaped mast channels, OHG legs and carriages)
- Armored glass "high view" overhead guard

Energy Efficient:

- Low operational engine RPM
- Engine RPM is automatic and demand-controlled
- Hydrostatic drive system with axial piston technology

High Performance:

- Hydrostatic drive system
- Standard dual pedal travel control
- Automatic acceleration and deceleration
- High torque engine at low RPM

H35 - H50 TECHNICAL DATA

					Linde		Linde		Linde		
					H35D/600 - H35T/600		H40D/600 - H40T/600		H45D/600 - H45T/600		
Characteristics	1.1	Manufacturer									
	1.2	Model									
	1.3	Power			Diesel / LP		Diesel / LP		Diesel / LP		
	1.4	Operation			seated		seated		seated		
	1.5	Capacity	Q	lb.	kg	7700	3500	8800	4000	9900	4500
	1.6	Load center	c	inch	mm	24	600	24	600	24	600
	1.8	Front overhang	x	inch	mm	19.6	500	20	510	21	535
	1.9	Wheelbase	y	inch	mm	79.9	2030	79.9	2030	81.5	2070
	2.1	Total truck weight		lb.	kg	12588	5722	13613	6188	14753	6706
	Weights	2.2.1	Axle loading laden front		lb.	kg	17967	8167	1944	9020	21938
2.2.2		Axle loading laden rear		lb.	kg	2321	1055	2569	1168	2714	1234
2.3.1		Axle loading empty front		lb.	kg	6094	2770	6232	2833	6611	3005
2.3.2		Axle loading empty rear		lb.	kg	6494	2952	7381	3355	8142	3701
3.1		Tire type				SE, solid pneumatic		SE, solid pneumatic		SE, solid pneumatic	
3.2		Tire size front				250/70-15 (250-15)		250/70-15 (250-15)		315/70-15 (300-15)	
3.3		Tire size rear				250/70-15 (250-15)		250/70-15 (250-15)		250/70-15 (250-15)	
Wheels/Tyres	3.6	Track width front	b10	inch	mm	48	1221	48	1221	46.8	1190
	3.7	Track width rear	b11	inch	mm	44.2	1123	44.2	1123	44.2	1123
	4.1	Tilt forward / Backward			degree	5/5 ¹⁾		5/5 ¹⁾		5/5 ¹⁾	
	4.7	Cab height	h6	inch	mm	95	2414	95	2414	96.7	2456
	4.8	Seat height	h7	inch	mm	51.1	1298	51.1	1298	52.8	1341
	4.12	Tow pin height	h10	inch	mm	26	660	26	660	26.6	675
	4.19	Overall length (42" forks)	l1	inch	mm	162.1	4117	162.6	4130	165	4191
	4.20	Length to fork face	l2	inch	mm	120.1	3051	120.5	3061	123	3126
	4.21	Overall width	b1	inch	mm	56.9	1446	56.9	1446	57	1448
	4.23	Type carriage			ITA	Class 3		Class 3		Class 3	
Dimensions	4.24	Carriage width	b3	inch	mm	53.2	1350	53.2	1350	53.1	1350
	4.31	Ground clearance mast	m1	inch	mm	6.2	158	6.2	158	8	203
	4.32	Ground clearance chassis	m2	inch	mm	8.1	207	8.1	207	9.8	250
	4.33	Aisle width (including 48" load)	Ast	inch	mm	183.9	4673	184.9	4698	186.6	4740
	4.34	Aisle width (add load, operating space)	Ast	inch	mm	128	3253	129	3278	130.7	3320
	4.35	Outer turning radius	Wa	inch	mm	108	2743	108	2743	109.6	2785
	4.36	Inner turning radius	b13	inch	mm	31.8	808	31.8	808	32.4	823
	5.1.1	Travel speed laden		mph	km / h	13	21	13	21	15	24
	5.1.2	Travel speed empty		mph	km / h	13	21	13	21	15	24
	5.2.1	Lift speed laden		fpm	m/s	104	0.53	104	0.53	104	0.53
5.2.2	Lift speed empty		fpm	m/s	112	0.57	112	0.57	112	0.57	
5.3.1	Lowering speed laden		fpm	m/s	110	0.56	110	0.56	110	0.56	
5.3.2	Lowering speed empty		fpm	m/s	104	0.53	104	0.53	104	0.53	
Performance	5.6.1	Max drawbar pull laden		lbf	N	6557	29171	6513	28972	5636	25072
	5.6.2	Max drawbar pull empty		lbf	N	4886	21735	5038	22413	5347	23786
	5.8.1	Max gradeability laden		%-Grade		34.1		30.2		23.4	
	5.8.2	Max gradeability empty		%-Grade		29.8		28.2		27.5	
	5.9.1	Acceleration tim laden		seconds		5.4		5.5		5.6	
	5.9.2	Acceleration time empty		seconds		4.9		4.9		5	
	5.10	Service brakes				hydrostatic		hydrostatic		hydrostatic	
	7.1	Engine manufacturer / Type				Doosan D24	Doosan P34	Doosan D24	Doosan P34	Doosan D24	Doosan P34
	7.2	Engine power rating		hp	kW	73	55	73	55	73	55
	7.3	Engine speed			rpm	2300	2300	2300	2300	2300	2300
7.4	Cylinders / Volume		in ³	cm ³	4142/2393	4208/3409	4142/2393	4208/3409	4 142/2393	4 208/3409	
Others	8.1	Drive unit				hydrostatic/stepless		hydrostatic/stepless		hydrostatic/stepless	
	10.1	Max. hydraulic operating pressure		psi	bar	2465	170	2465	170	2465	170
	10.2	Max hydraulic oil flow		gpm	lpm	14	55	14	55	14	55
	10.4	Fuel tank capacity		gallon	liter	20	76	20	76	20	76
	8.4	Noise level (at driver's ear)			dB A	79		79		79	

*1) tilt angle 5f/8b with standard and duplex masts

H35 - H50 TECHNICAL DATA

					Linde		Linde			
					H50D - H50T		H50D/600 - H50T/600			
Characteristics	1.1	Manufacturer								
	1.2	Model								
	1.3	Power			Diesel / LP		Diesel / LP			
	1.4	Operation			seated		seated			
	1.5	Capacity	Q	lb.	kg	10000	5000	11000	5000	
	1.6	Load center	c	inch	mm	24	500	24	600	
	1.8	Front overhang	x	inch	mm	21	535	21	535	
	1.9	Wheelbase	y	inch	mm	81.5	2070	83.0	2110	
	2.1	Total truck weight		lb.	kg	14700	6682	15591	7087	
Weights	2.2.1	Axle loading laden front		lb.	kg	23030	10464	23737	10767	
	2.2.2	Axle loading laden rear		lb.	kg	2679	1218	2907	1319	
	2.3.1	Axle loading empty front		lb.	kg	6523	2965	6788	3079	
	2.3.2	Axle loading empty rear		lb.	kg	8177	3717	8836	4008	
	Wheels/Tyres	3.1	Tire type			SE, solid pneumatic		SE, solid pneumatic		
3.2		Tire size front			315/70-15 (300-15)		315/70-15 (300-15)			
3.3		Tire size rear			250/70-15 (250-15)		250/70-15 (250-15)			
3.6		Track width front	b10	inch	mm	46.9	1190	46.8	1190	
3.7		Track width rear	b11	inch	mm	44.2	1123	44.2	1123	
4.1		Tilt forward / backward		degree		5/5 ¹⁾		5/5 ¹⁾		
Dimensions		4.7	Cab height	h6	inch	mm	96.7	2456	96.7	2456
	4.8	Seat height	h7	inch	mm	52.8	1341	52.8	1341	
	4.12	Tow pin height	h10	inch	mm	26.6	675	26.6	675	
	4.19	Overall length (42" forks)	l1	inch	mm	165	4191	166.6	4231	
	4.20	Length to fork face	l2	inch	mm	123	3126	124.6	3166	
	4.21	Overall width	b1	inch	mm	57	1448	57	1448	
	4.23	Type carriage		ITA		Class 3		Class 3		
	4.24	Carriage width	b3	inch	mm	53.2	1350	53.2	1350	
	4.31	Ground clearance mast	m1	inch	mm	8	203	8	203	
	4.32	Ground clearance chassis	m2	inch	mm	9.8	250	9.8	250	
	4.33	Aisle width (including 48" load)	Ast	inch	mm	186.6	4740	188.3	4783	
	4.34	Aisle width (add load, operating space)	Ast	inch	mm	130.7	3320	132.4	3363	
	4.35	Outer turning radius	Wa	inch	mm	109.6	2785	111.3	2828	
	4.36	Inner turning radius	b13	inch	mm	32.4	823	32.9	838	
	Performance	5.1.1	Travel speed laden		mp / h	km / h	15	24	15	24
		5.1.2	Travel speed empty		mp / h	km / h	15	24	15	24
5.2.1		Lift speed laden		fpm	m/s	104	0.53	104	0.53	
5.2.2		Lift speed empty		fpm	m/s	112	0.57	112	0.57	
5.3.1		Lowering speed laden		fpm	m/s	106	0.54	106	0.54	
5.3.2		Lowering speed empty		fpm	m/s	100	0.51	100	0.51	
5.6.1		Max drawbar pull laden		lbf	N	5609	24951	5598	24903	
5.6.2		Max drawbar pull empty		lbf	N	5339	23753	5442	24209	
5.8.1		Max gradeability laden		% -Grade		22.2		21.5		
5.8.2		Max gradeability empty		% -Grade		27.5		26.7		
5.9.1		Acceleration time laden		seconds		5.7		5.8		
5.9.2		Acceleration time empty		seconds		5		5.1		
5.10		Service brakes				hydrostatic		hydrostatic		
Drive	7.1	Engine manufacturer / Type				Doosan D24	Doosan P34	Doosan D24	Doosan P34	
	7.2	Engine power rating		hp	kW	73	55	73	55	
	7.3	Engine speed		rpm		2300		2300		
	7.4	Cylinders / Volume		in ³	cm ³	4 142/2393	4 208/3409	4 142/2393	4 208/3409	
Others	8.1	Drive unit				hydrostatic/stepless		hydrostatic/stepless		
	10.1	Max. Hydraulic operating pressure		psi	bar	2465	170	2465	170	
	10.2	Max hydraulic oil flow		gpm	lpm	14	55	14	55	
	10.4	Fuel tank capacity		gallon	liter	20	76	20	76	
	8.4	Noise level (at driver's ear)		dB A		70		79		

*1) tilt angle 5f/8b with standard and duplex masts

H35 - H50 TECHNICAL DATA

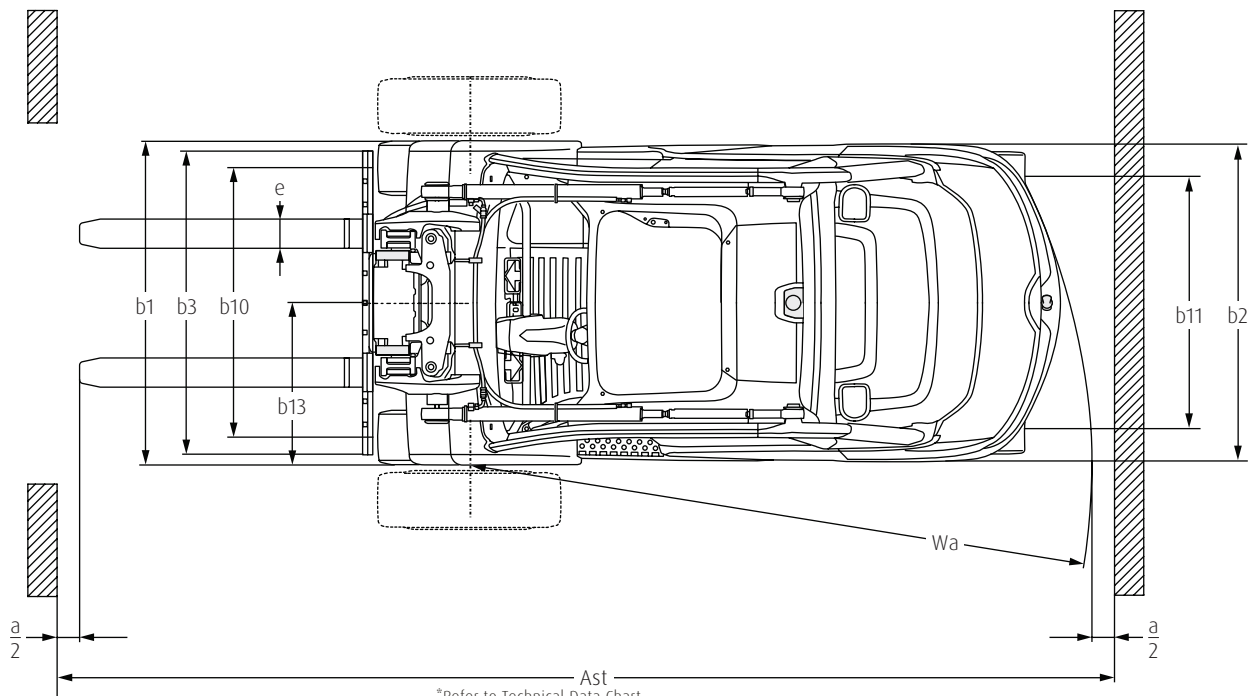
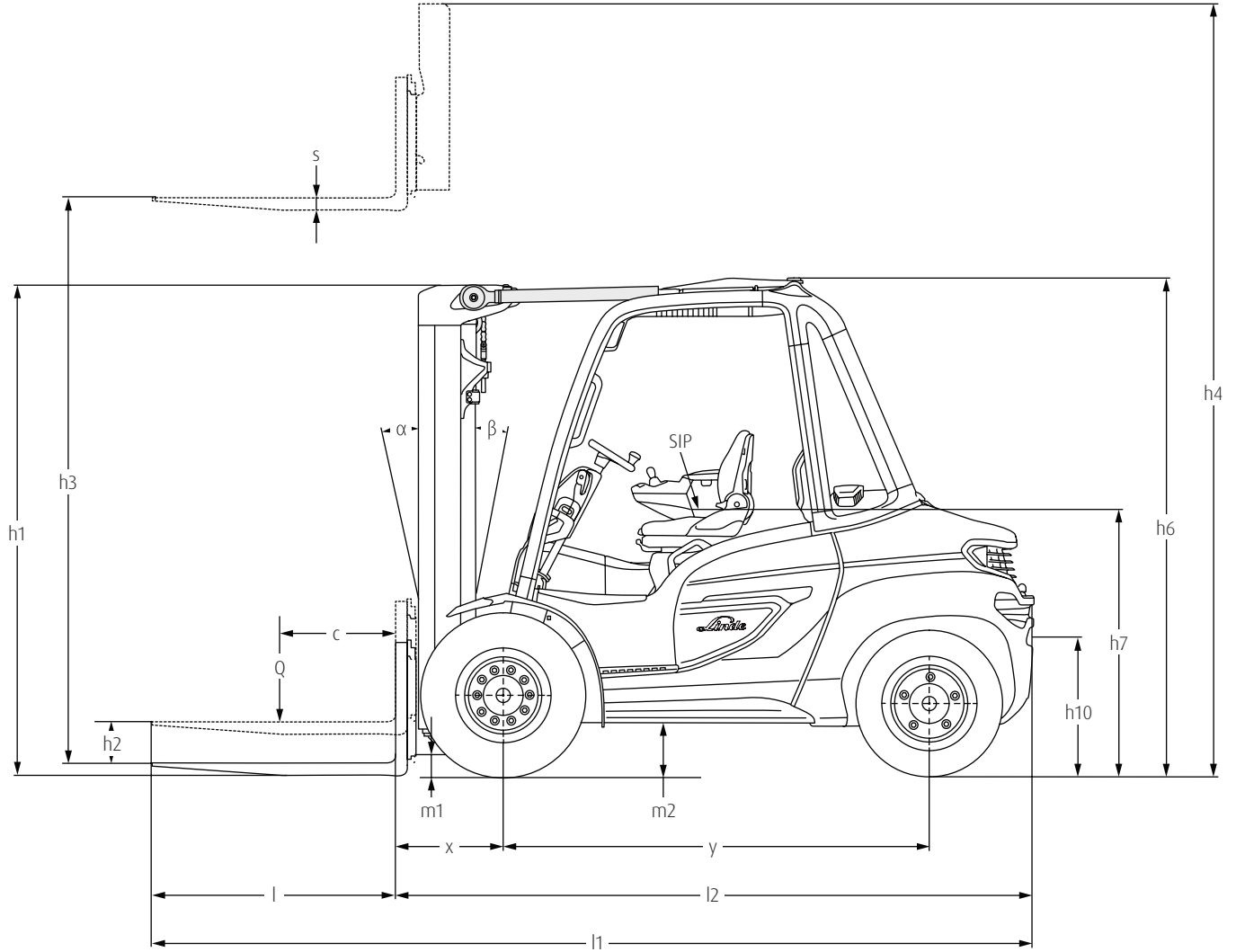

*Refer to Technical Data Chart

H35 - H50 CAPACITY RATINGS

H35/600

2.5" x 5" x 48" Forks Class 3 SGL 250-15 SE (SGL 28X12.5-15 SE for Low Profile OHG)

**Cascade HOSS 100F-SSS-B017

Mast Information					Capacity @ 24" Load Center			
h1 (in)	h3 (in)	h2 (in)	Type	Tilt	Std. Carriage [lb]	Integral SS Carr. [lb]	53" HOSS** [lb]	Integral SS FP [lb]
95.7	122.0	0.0	Standard	5° F/8° B	7700	7700	7525	tba
97.6	126.0	0.0	Standard	5° F/8° B	7700	7700	7525	tba
101.6	133.9	0.0	Standard	5° F/8° B	7700	7700	7525	tba
107.5	145.7	0.0	Standard	5° F/8° B	7700	7700	7525	tba
111.4	153.5	0.0	Standard	5° F/8° B	7700	7700	7525	tba
115.4	161.4	0.0	Standard	5° F/8° B	7700	7700	7525	tba
125.2	181.1	0.0	Standard	5° F/8° B	7700	7700	7525	tba
85.4	107.5	48.2	Duplex	5° F/8° B	7700	7700	7525	tba
93.7	123.2	56.1	Duplex	5° F/8° B	7700	7700	7525	tba
95.7	127.2	58.1	Duplex	5° F/8° B	7700	7700	7525	tba
99.6	135.0	62.0	Duplex	5° F/8° B	7700	7700	7525	tba
105.5	146.9	67.9	Duplex	5° F/8° B	7700	7700	7525	tba
113.4	162.6	75.8	Duplex	5° F/8° B	7700	7700	7525	tba
85.4	160.4	48.2	Triplex	5° F/5° B	7700	7700	7525	tba
93.7	184.1	56.1	Triplex	5° F/5° B	7700	7700	7525	tba
95.7	187.6	58.1	Triplex	5° F/5° B	7700	7700	7525	tba
99.6	199.4	62.0	Triplex	5° F/5° B	7700	7700	7525	tba
103.5	211.2	65.9	Triplex	5° F/5° B	7700	7700	7525	tba

H40/600

2.5" x 5" x 48" Forks Class 3 SGL 250-15 SE (SGL 28X12.5-15 SE for Low Profile OHG)

**Cascade HOSS 100F-SSS-B017

Mast Information					Capacity @ 24" Load Center			
h1 (in)	h3 (in)	h2 (in)	Type	Tilt	Std. Carriage [lb]	Integral SS Carr. [lb]	53" HOSS** [lb]	Integral SS FP [lb]
95.7	122.0	0.0	Standard	5° F/8° B	8800	8800	8750	tba
97.6	126.0	0.0	Standard	5° F/8° B	8800	8800	8750	tba
101.6	133.9	0.0	Standard	5° F/8° B	8800	8800	8750	tba
107.5	145.7	0.0	Standard	5° F/8° B	8800	8800	8750	tba
111.4	153.5	0.0	Standard	5° F/8° B	8800	8800	8750	tba
115.4	161.4	0.0	Standard	5° F/8° B	8800	8800	8750	tba
125.2	181.1	0.0	Standard	5° F/8° B	8800	8800	8750	tba
85.4	107.5	48.2	Duplex	5° F/8° B	8800	8800	8750	tba
93.7	123.2	56.1	Duplex	5° F/8° B	8800	8800	8750	tba
95.7	127.2	58.1	Duplex	5° F/8° B	8800	8800	8750	tba
99.6	135.0	62.0	Duplex	5° F/8° B	8800	8800	8750	tba
105.5	146.9	67.9	Duplex	5° F/8° B	8800	8800	8750	tba
113.4	162.6	75.8	Duplex	5° F/8° B	8800	8800	8750	tba
85.4	160.4	48.2	Triplex	5° F/5° B	8800	8800	8750	tba
93.7	184.1	56.1	Triplex	5° F/5° B	8800	8800	8750	tba
95.7	187.6	58.1	Triplex	5° F/5° B	8800	8800	8750	tba
99.6	199.4	62.0	Triplex	5° F/5° B	8800	8800	8750	tba
103.5	211.2	65.9	Triplex	5° F/5° B	8800	8800	8700	tba

H35 - H50 CAPACITY RATINGS

H45/600

2.5" x 5" x 48" Forks Class 3 SGL 300-15 SE

**Cascade HOSS 100F-SSS-B017

Mast Information					Capacity @ 24" Load Center			
h1 (in)	h3 (in)	h2 (in)	Type	Tilt	Std. Carriage [lb]	Integral SS Carr. [lb]	53" HOSS** [lb]	Integral SS FP [lb]
97.6	122.0	0.0	Standard	5° F/8° B	9900	9900	9775	tba
99.6	126.0	0.0	Standard	5° F/8° B	9900	9900	9775	tba
103.5	133.9	0.0	Standard	5° F/8° B	9900	9900	9775	tba
109.4	145.7	0.0	Standard	5° F/8° B	9900	9900	9775	tba
113.4	153.5	0.0	Standard	5° F/8° B	9900	9900	9775	tba
117.3	161.4	0.0	Standard	5° F/8° B	9900	9900	9775	tba
127.2	181.1	0.0	Standard	5° F/8° B	9900	9900	9775	tba
85.4	107.5	48.2	Duplex	5° F/8° B	9900	9900	9775	tba
95.7	123.2	56.1	Duplex	5° F/8° B	9900	9900	9775	tba
97.6	127.2	58.1	Duplex	5° F/8° B	9900	9900	9775	tba
101.6	135.0	62.0	Duplex	5° F/8° B	9900	9900	9775	tba
107.5	146.9	67.9	Duplex	5° F/8° B	9900	9900	9775	tba
115.4	162.6	75.8	Duplex	5° F/8° B	9900	9900	9775	tba
85.4	160.4	48.2	Triplex	5° F/5° B	9900	9900	9775	tba
95.7	184.1	56.1	Triplex	5° F/5° B	9900	9900	9775	tba
97.6	187.6	58.1	Triplex	5° F/5° B	9900	9900	9775	tba
101.6	199.4	62.0	Triplex	5° F/5° B	9900	9900	9775	tba
105.5	211.2	65.9	Triplex	5° F/5° B	9900	9900	9775	tba

H50

2.5" x 6" x 48" Forks Class 3 SGL 300-15 SE

**Cascade HOSS 100F-SSS-B017

Mast Information					Capacity @ 24" Load Center			
h1 (in)	h3 (in)	h2 (in)	Type	Tilt	Std. Carriage [lb]	Integral SS Carr. [lb]	53" HOSS** [lb]	Integral SS FP [lb]
97.6	114.2	0.0	Standard	5° F/8° B	10000	10000	9850	tba
103.5	126.0	0.0	Standard	5° F/8° B	10000	10000	9850	tba
113.4	145.7	0.0	Standard	5° F/8° B	10000	10000	9850	tba
121.3	161.4	0.0	Standard	5° F/8° B	10000	10000	9850	tba
135.0	189.0	0.0	Standard	5° F/8° B	10000	10000	9850	tba
85.4	99.6	48.2	Duplex	5° F/8° B	10000	10000	9850	tba
95.7	115.4	56.1	Duplex	5° F/8° B	10000	10000	9850	tba
97.6	119.3	58.1	Duplex	5° F/8° B	10000	10000	9850	tba
101.6	127.2	62.0	Duplex	5° F/8° B	10000	10000	9850	tba
107.5	139.0	67.9	Duplex	5° F/8° B	10000	10000	9850	tba
115.4	154.7	75.8	Duplex	5° F/8° B	10000	10000	9850	tba
85.4	148.6	48.2	Triplex	5° F/5° B	10000	10000	9850	tba
95.7	172.2	56.1	Triplex	5° F/5° B	10000	10000	9850	tba
99.6	181.7	58.1	Triplex	5° F/5° B	10000	10000	9850	tba
105.5	199.4	62.0	Triplex	5° F/5° B	10000	10000	9850	tba
113.4	219.1	65.9	Triplex	5° F/5° B	10000	9700	9400	tba

H35 - H50 CAPACITY RATINGS

H50/600

2.5" x 6" x 48" Forks Class 3 SGL 300-15 SE

**Cascade HOSS 100F-SSS-B017

Mast Information					Capacity @ 24" Load Center			
h1 (in)	h3 (in)	h2 (in)	Type	Tilt	Std. Carriage [lb]	Integral SS Carr. [lb]	53" HOSS** [lb]	Integral SS FP [lb]
97.6	114.2	0.0	Standard	5° F/8° B	11000	11000	10000	tba
103.5	126.0	0.0	Standard	5° F/8° B	11000	11000	10000	tba
113.4	145.7	0.0	Standard	5° F/8° B	11000	11000	10000	tba
121.3	161.4	0.0	Standard	5° F/8° B	11000	11000	10000	tba
135.0	189.0	0.0	Standard	5° F/8° B	11000	11000	10000	tba
85.4	99.6	48.2	Duplex	5° F/8° B	11000	11000	10000	tba
95.7	115.4	56.1	Duplex	5° F/8° B	11000	11000	10000	tba
97.6	119.3	58.1	Duplex	5° F/8° B	11000	11000	10000	tba
101.6	127.2	62.0	Duplex	5° F/8° B	11000	11000	10000	tba
107.5	139.0	67.9	Duplex	5° F/8° B	11000	11000	10000	tba
115.4	154.7	75.8	Duplex	5° F/8° B	11000	11000	10000	tba
85.4	148.6	48.2	Triplex	5° F/5° B	11000	11000	10000	tba
95.7	172.2	56.1	Triplex	5° F/5° B	11000	11000	10000	tba
99.6	181.7	58.1	Triplex	5° F/5° B	11000	11000	10000	tba
105.5	199.4	62.0	Triplex	5° F/5° B	11000	11000	10000	tba
113.4	219.1	65.9	Triplex	5° F/5° B	10375	10225	10000	tba





Built for All Conditions

The Linde Series 1204 represents everything that Linde forklift trucks stand for. It is extremely powerful, user-friendly, robust, and versatile with the ability to operate in countless applications.

- A **fully enclosed belly pan** prevents unwanted dirt and debris from entering the engine area, increasing the ability to operate in dirty and dusty applications, exposed to loose lint, paper, or debris.
- **Automatic acceleration and deceleration** promotes infinite speed control, delivering smoother transitions with speed.
- **Overhead tilt cylinders** ensure the operator is working effectively and confidently, stabilizing the load at high lift heights.
- The **high periphery view** mast aids in the prevention of loading accidents, as well as ensuring outstanding visibility in all directions.



This vehicle offers durability, efficiency, and productivity, resulting in the best solution for your material flow requirements, both now and in the future.





DESIGNED FOR EFFICIENCY

Thanks to the optimized design of the chassis, cabin, and mast, drivers now have an even better view in all directions. The particularly narrow A-pillar gives the driver good visibility of the load and their surroundings. Due to shaped mast rails, all-around visibility is even more exceptional and unmatched. An additional improvement is the lowered front plate, allowing a better view of the forks and load. The Linde Series 1204 is designed for efficiency, without compromise.

- **Armrest controls**, within an ergonomic workstation, enable precise operation
- **Nested mast rail** offers unmatched all-around visibility, increasing driver confidence
- **Low noise level** promotes an exceptional driving experience
- **A full suspension seat** decreases operator fatigue
- An optional **panoramic armored glass roof** guarantees the best view upwards
- Swing-down **dual LP bottle holder** will take the strain out of exchanging LP bottles and extend operation



CHARACTERISTICS

Linde Material Handling

Linde

Member of KION Group



ERGONOMICS

- Ergonomic and intuitive operating concept maximizes driver comfort
- Neoprene bearings between chassis, mast, and tilt cylinder reduce negative effect of impact and vibrations
- Large variety of available seats, assist in preventing operator fatigue
- 3.5" color graphic display provides easy to read truck status



HANDLING

- Linde Load Control and dual pedal travel control ensure precise operation of all movements
- Programmable "smart" buttons allow quick access to frequently used functions
- Overhead tilt cylinders enhance torsional stability and allow superior residual capacity at high lift heights
- Fuel consumption is minimized through low-average engine RPM – effectively reducing operating cost



CONFIDENCE

- Shaped overhead guard legs and mast profiles, together with unique hose routing deliver outstanding all-around visibility
- Optional armored glass overhead guard top will allow unsurpassed load visibility at elevated heights
- Low center of gravity and high mounted (pivoting) steer axle enhance stability while cornering
- Linde assist systems support the operator in avoiding tip over situations



SERVICE

- Robust construction with low wear or even maintenance-free components ensure high truck uptime
- Truck "health status" monitoring assists in effective fleet management programs
- Linde Engine Protection System provides additional protection against engine damage
- Extra-large service access openings facilitate easy component access



MONTREAL (Head office)

19151 A, Cruickshank Avenue
Baie-D'Urfé (Québec) H9X 3N9
Phone: 418 694-4223
Toll free: 1 866 421-4223
info@elevex.ca
elevex.ca

QUEBEC

1279, Paul-Émile Giroux St. Suite 200
Québec (Québec) G1C 0K9

SAGUENAY

2305, Alexis-Le-Trotteur
St. Jonquière (Québec) G7X 9H8

