



Diesel Forklift Trucks
13,000 to 17,500 lbs. Capacity
H60D, H70D, H80D, H80D-900, and H80D-1100
SERIES 396-03

Safety

With full loads weighing as much as 17500 lbs. at 43" load center and full capacity up to 256" of lift height—safety is priority number one. The Linde Torsion Support System and mast design are the fundamental reasons for stability when handling wide, swinging loads generating high dynamic forces.

Performance

These trucks are engineered to take care of the really tough jobs. Advanced engine design and Linde hydrostatic drive technology enable the operator to accelerate and decelerate smoothly and without shift-shock, at slow pace or at full speed. Without effort, using the original Linde Load Control, the driver manipulates the load efficiently and quickly in any condition. Precise control of all movements is the key to high performance.

Comfort

Man and machine are perfectly matched on these high capacity forklifts. Designed to the most advanced ergonomic standards, the generously sized driver's cab provides a comfortable work environment. Fully adjustable seat and armrest contribute to minimizing stress and fatigue. Fingertip hydraulic controls, designed into the armrest, add further to the fatigue free operation.

Linde Material Handling



Reliability & Durability

50 years of experience with hydrostatic drive systems are combined with a robust, industrial diesel engine, the result, utmost reliability. This combination has consistently proven dependable in even the most challenging environments. This machine is effective and cost efficient without equal.

Economic

The original Linde hydrostatic system operates without mechanical transmission, torque converter, clutch, differential axle and conventional brakes. The net effect: low operating cost and increased productivity, a significant advantage especially in high cycle applications.

Standard and optional equipment

Standard equipment:

Direct injection, turbo charged, 4.1 liter (246 cubic inches) diesel engine with intercooler, providing 114 hp

Twin pedal drive system

SE tires

Armrest with Linde Load Control

Hydraulic suspension, high comfort driver seat

Tilttable steering wheel

Hydrostatic power steering

Torsion distribution system

High performance filter system

Comprehensive display

Options:

Single pedal travel control

Tire options, Radial, twin, etc..

Special carriages

Integrated sidershifters and fork positioners

Complete cabs

Heating and cooling

Seat options

Lighting options

Various custom options and packages

Many other options available on request

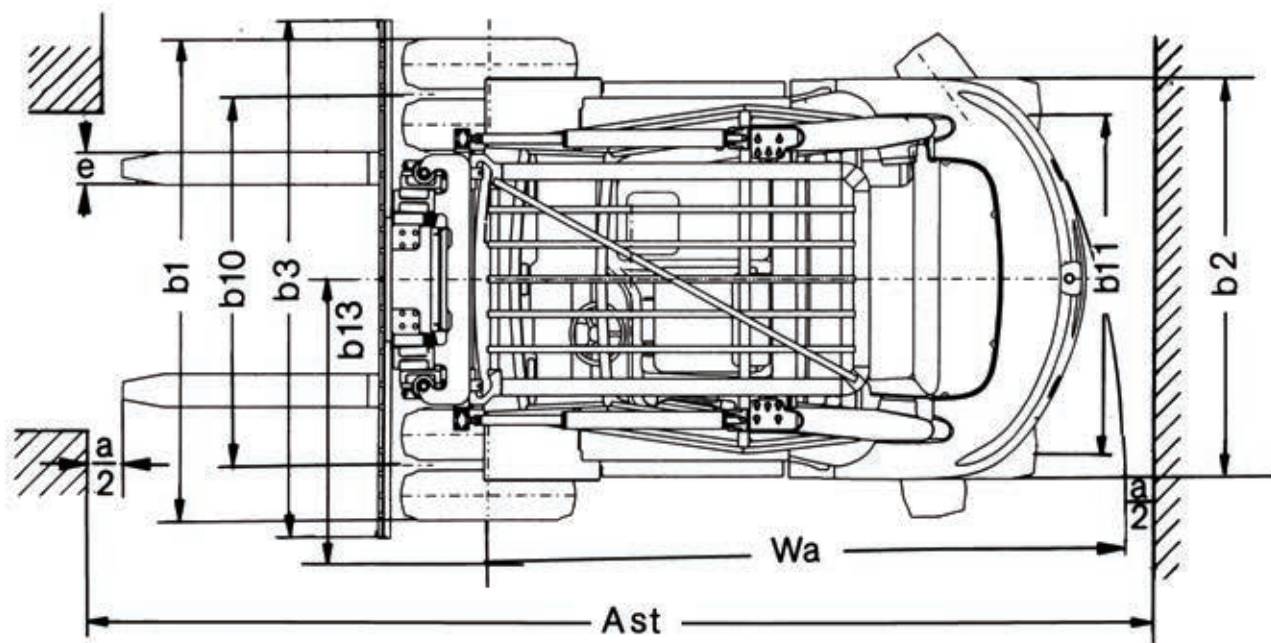
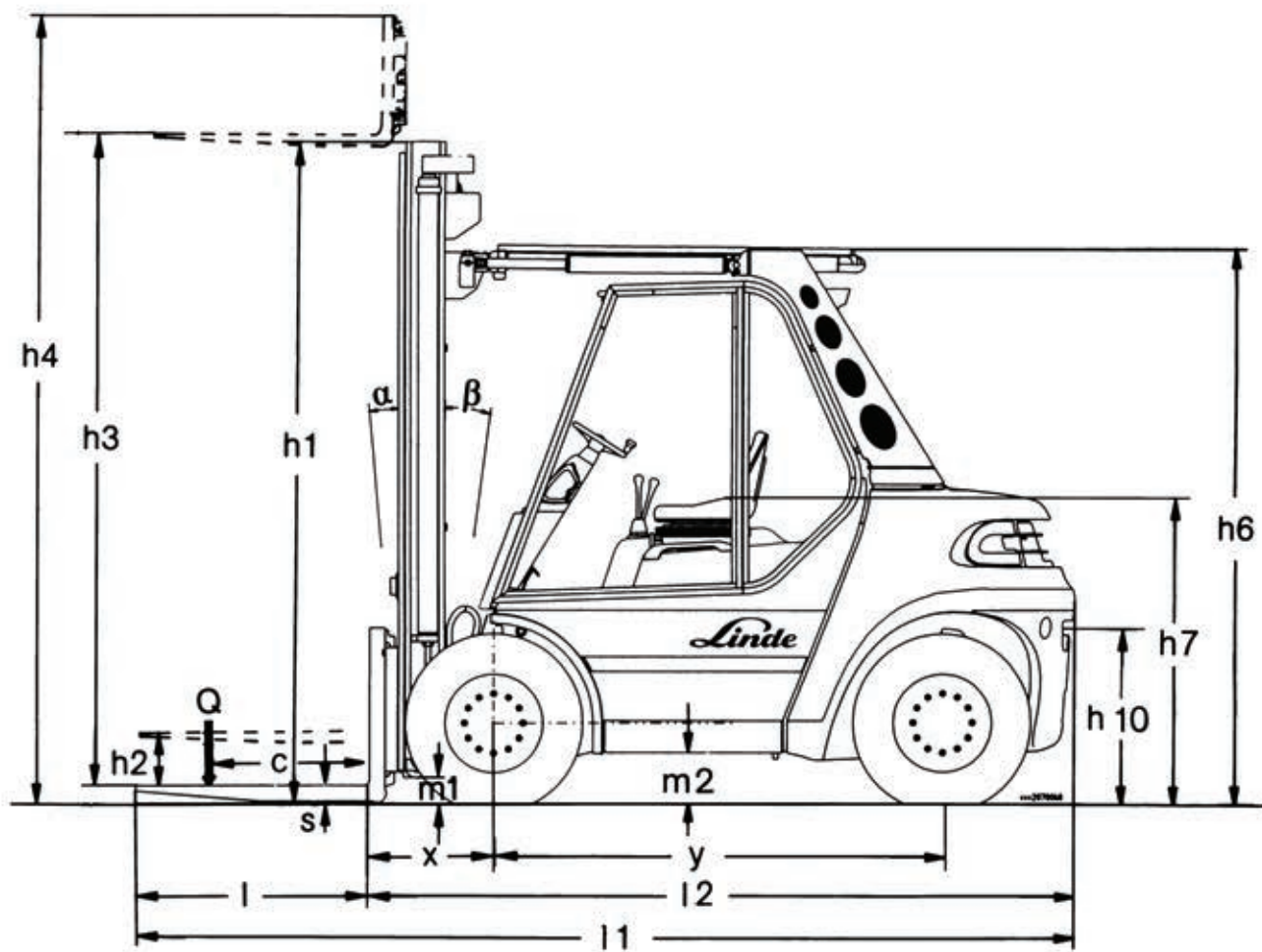

Technical data

January 2013

SERIES 396-03

Characteristics	1.1	Manufacturer		
	1.2	Model designation		
	1.3	Power unit: battery, diesel, gasoline, LP gas		
	1.4	Operation: manual, pedestrian, rider standing, rider seated, order picker		
	1.5	Load capacity		Q lb
	1.6	Load center		c in
	1.8	Load distance (axle center to fork face)		x in
	1.9	Wheelbase		y in
Weight	2.1	Service weight		lb
	2.2	Axle loading with load, front/rear		lb
	2.3	Axle loading without load, front/rear		lb
Wheels & Tires	3.1	Tire type - front/rear: C (cushion), SE (cushion super elastic), P (pneumatic)		
	3.2	Tire size: front		in
	3.3	Tire size: rear		in
	3.5	Wheels: number front (x = driven)/rear		
	3.6	Track width, front/rear		b10 in
	Dimensions	4.1	Mast/fork carriage tilt: forward/ backward (simplex mast)	
4.2		Height of mast lowered		h1 in
4.3		Free lift		h2 in
4.4		Lift		h3 in
4.5		Height of mast extended		h4 in
4.7		Height of overhead guard/cab		h6 in
4.8		Height of seat		h7 in
4.12		Height of tow coupling		h10 in
4.19		Overall length		l1 in
4.20		Length to fork face		l2 in
4.21		Overall width		b1 in
4.22		Fork dimensions		s/e/l in
4.23		Fork carriage		
4.24		Width of fork carriage		b3 in
4.31		Ground clearance under mast, with load		m1 in
4.32		Ground clearance, center of wheelbase		m2 in
4.34		Aisle width (48" long load)		Ast in
4.35	Outer turning radius		Wa in	
4.36	Inner turning radius		b13 in	
Performance	5.1	Travel speed, with/without load		mph
	5.2	Lifting speed, with/without load		fpm
	5.3	Lowering speed, with/without load		fpm
	5.5	Drawbar pull, with/without load		lbs
	5.7	Gradeability, with/without load		%
	5.9	Acceleration time to max. speed, with/without load		s
	5.10	Service brake		
IC - Engine	7.1	Engine manufacturer/model		
	7.2	Engine output to ISO 1585		hp
	7.3	Rated speed		rpm
	7.4	Number of cylinders/engine displacement		cu in
Other	8.1	Drive control		
	8.2	Working pressure for attachments		psi
	8.3	Oil flow for attachments		gal/min
	8.4	Maximum noise level at driver's ear (to EN 12053)		dBa

¹ Other tires optional

² 68.8 with twin tires

³ Less with triplex mast, check factory

Series 396-03 (H60D, H70D, H80D, H80D-900, and H80D-1100)

	Linde	Linde	Linde	Linde	Linde	1.1
	H60D	H70D	H80D	H80D-900	H80D-1100	1.2
	Diesel	Diesel	Diesel	Diesel	Diesel	1.3
	Seated	Seated	Seated	Seated	Seated	1.4
	13000	15000	17500	17500	17500	1.5
	24	24	24	36	43	1.6
	24.8	25.2	25.2	26.4	26.4	1.8
	86.6	86.6	86.6	98.8	110.6	1.9
	22418	25090	27193	30950	32789	2.1
	31415 / 4230	35262 / 5260	39427 / 5492	43485 / 5101	45384 / 5042	2.2
	10791 / 11627	11133 / 13957	11762 / 15432	14817 / 16133	16574 / 16215	2.3
	SE	SE twin	SE twin	SE twin	SE twin	3.1
	355 / 65-15 ¹⁾	8.25-15 ¹⁾	8.25-15 ¹⁾	8.25-15 ¹⁾	315 / 70-15 ¹⁾	3.2
	315/70-15 ¹⁾	315/70-15 ¹⁾	315/70-15 ¹⁾	315/70-15 ¹⁾	315/70-15 ¹⁾	3.3
	2 x / 2	4 x / 2	4 x / 2	4 x / 2	4 x / 2	3.5
	62.75 ²⁾ / 63	68.81 / 63	68.81 / 63	68.81 / 63	69.0 / 63	3.6
	5° / 9°	5° / 9°	5° / 9°	5° / 9°	5° / 9°	4.1
	See mast table	See mast table	See mast table	See mast table	See mast table	4.2
	See mast table	See mast table	See mast table	See mast table	See mast table	4.3
	See mast table	See mast table	See mast table	See mast table	See mast table	4.4
	See mast table	See mast table	See mast table	See mast table	See mast table	4.5
	108.11	108.11	108.11	108.11	108.11	4.7
	59.40	59.40	59.40	59.40	59.40	4.8
	32.7	32.7	32.7	32.7	32.7	4.12
	185.8	186.2	186.2	221.6	249.5	4.19
	138.5	138.9	138.9	150.8	163.0	4.20
	74.8	87.8	87.8	87.8	90.5	4.21
	2.5 / 48 / 6	2.75 / 48 / 6	2.75 / 48 / 8	2.75 / 72 / 8	2.75 / 84 / 8	4.22
	4	4	4	4	4	4.23
	71	86	86	86	86	4.24
	8.2	8.2	8.2	8.2	8.2	4.31
	9.8	9.8	9.8	9.8	9.8	4.32
	205.4	205.7	205.7	213.95	228.5	4.34
	125.5	125.5	125.5	138.2	151.6	4.35
	41.8	41.8	41.8	48.8	55.5	4.36
	14.4	14.4	14.4	14.4	14.4	5.1
	112 / 114	90 / 106	90.5 / 106.3	90.5 / 106.3	90.5 / 106.3	5.2
	110 / 104	110 / 104	110 / 104.3	110 / 104.3	110 / 104.3	5.3
	11240 / 7868	11465 / 10341	10116 / 9217	11685 / 11290	12135 / 12262	5.5
	30 / 36	28 / 35	26 / 34	24 / 34	23 / 34	5.7
	5.6 / 5	5.7 / 5.1	5.8 / 5.2	6 / 5.2	6.1 / 5.3	5.9
	Hydrostatic	Hydrostatic	Hydrostatic	Hydrostatic	Hydrostatic	5.10
	Deutz TCD 4.1 L4	Deutz TCD 4.1 L4	Deutz TCD 4.1 L4	Deutz TCD 4.1 L4	Deutz TCD 4.1 L4	7.1
	114	114	114	114	114	7.2
	2200	2200	2200	2200	2200	7.3
	4 / 246	4 / 246	4 / 246	4 / 246	4 / 246	7.4
	Hydrostatic	Hydrostatic	Hydrostatic	Hydrostatic	Hydrostatic	8.1
	3843	3843	3843	3843	3843	8.2
	25 ³⁾	25 ³⁾	25 ³⁾	25 ³⁾	25 ³⁾	8.3
	77	77	77	77	77	8.4

Downrating charts*

Reference SE tires, standard carriage

Class IV forks

H60D (396-03)

Load Center Lifting Capacity Diagram

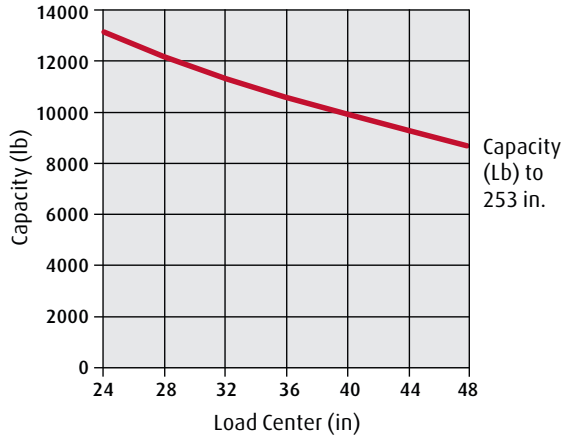

H70D (396-03)

Load Center Lifting Capacity Diagram

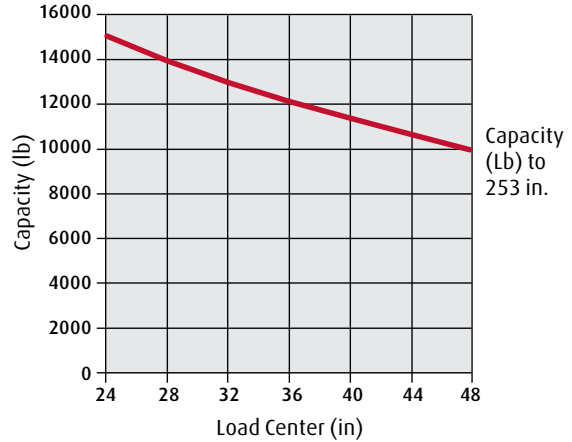

H80D (396-03)

Load Center Lifting Capacity Diagram

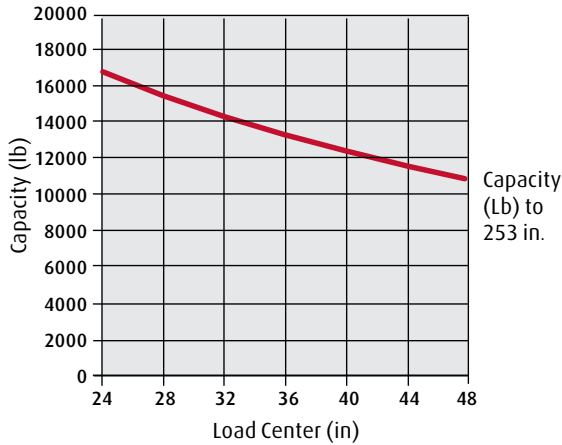

H80D-900 (396-03)

Load Center Lifting Capacity Diagram

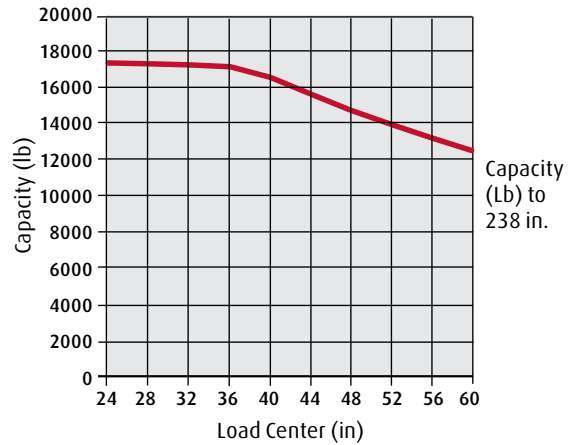

H80D-1100 (396-03)

Load Center Lifting Capacity Diagram

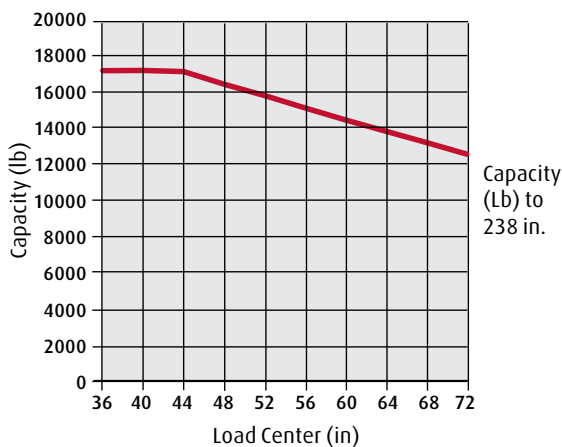

Capacity and mast information*

h1 (in.)	h3 (in.)	Type	Capacity (lb.)	Tilt (°F/°B)
H60D Capacity (lb) @ 24" load center** • 2.5" x 6" x 48" Std taper Class IV forks** • Single SE 355/65 - 15 drive tires**				
107.5	140.0	Simplex	13000	5/9
119.5	163.5	Simplex	13000	5/9
127.5	179.5	Simplex	13000	5/9
141.0	207.0	Simplex	13000	5/9
157.0	238.5	Simplex	13000	5/9
H70D Capacity (lb) @ 24" load center** • 2.75" x 8" x 48" Std taper Class IV forks** • Dual SE 8.25 - 15 drive tires**				
107.5	124.0	Simplex	15000	5/9
119.5	148.0	Simplex	15000	5/9
127.5	163.5	Simplex	15000	5/9
141.0	191.0	Simplex	15000	5/9
157.0	222.5	Simplex	15000	5/9
H80D Capacity (lb) @ 24" load center** • 2.75" x 6" x 48" Std taper Class IV forks** • Dual SE 8.25 - 15 drive tires**				
107.5	124.0	Simplex	17500	5/9
119.5	148.0	Simplex	17500	5/9
127.5	163.5	Simplex	17500	5/9
141.0	191.0	Simplex	17500	5/9
157.0	222.5	Simplex	17500	5/9
H80D-900 Capacity (lb) @ 36" load center** • 2.75" x 8" x 72" Std taper Class IV forks** • Dual SE 8.25 - 15 drive tires**				
107.5	108.5	Simplex	17500	5/9
119.5	132.0	Simplex	17500	5/9
127.5	148.0	Simplex	17500	5/9
141.0	175.5	Simplex	17500	5/9
H80D-1100 Capacity (lb) @ 43" load center** • 2.75" x 8" x 84" Std taper Class IV forks** • Dual SE 315/70 - 15 drive tires**				
107.5	108.5	Simplex	17500	5/9
119.5	132.0	Simplex	17500	5/9
127.5	148.0	Simplex	17500	5/9
141.0	175.5	Simplex	17500	5/9

* For quick reference only, contact factory for detailed ratings.

** Capacity ratings can be affected by changing forks, load center, and/or tires.

Features

Linde hydrostatic drive system

- Responsive, smooth, precise
- No mechanical wear components
- Robust, well proven in severe applications
- Low maintenance cost
- Long service life



Linde clear-view mast

- Superior visibility
- Full capacity to 256"/268"
- Unmatched residual capacity with attachments

Linde twin pedal travel control

- Instantaneous directional changes
- Precise control without shift shock
- Lower fatigue, improved productivity

Linde Load Control (LLC)

- Effortless load handling with fingertip control
- Precision placement and transfer of loads
- Complete separation of travel and hydraulic functions

Linde truck control

- Automatic engine speed control
- Redundant monitoring systems
- Fully sealed electronic controller



Linde operator compartment

- Unmatched visibility
- Advanced ergonomic design
- Spacious
- Floating, shock mounted cab

Power plant

- Industrial Deutz Diesel engine complying to EPA Tier 4 requirements
- High torque, 348 lbf at 1600 rpm
- Electronic engine management
- Low emissions
- Fuel tank 21.0 gallons

Linde torsion distribution system

- Reduction of mast distortion up to 30%
- High residual capacity
- Overhead tilt cylinders



ANSI: Standard truck meets all applicable mandatory requirements of ANSI/ITSDF B56.1 standards for powered industrial trucks.
NOTE: Performance data may vary due to motor and system efficiency tolerances. The performance depicted represents nominal values obtained under typical operating conditions. Metric dimensions are in millimeters unless otherwise specified. All metric dimensions are not direct equivalents due to rounding data. The descriptions and specifications included on this data sheet were in effect at the time of printing. Linde Material Handling North America Corporation reserves the right to make improvements and changes in specification or design without notice and without incurring obligation. Please check with your authorized Linde dealer for information on possible updates or revisions.



MONTREAL (Head office)

19151 A, Cruickshank Avenue
Baie-D'Urfé (Québec) H9X 3N9
Phone: 418 694-4223
Toll free: 1 866 421-4223
info@elevex.ca
elevex.ca

QUEBEC

1279, Paul-Émile Giroux St. Suite 200
Québec (Québec) G1C 0K9

SAGUENAY

2305, Alexis-Le-Trotteur
St. Jonquière (Québec) G7X 9H8



lind_e_spec_396-03 (diesel)
USA_v1 (01042016) 0729F