



Electric Counterbalance Trucks

5000 lb. to 7000 lb. Capacity

E25S, E25SH, E30S, E30SH, E35SH

SERIES 1276

Safety

Excellent visibility through the mast is a key element of forklift safety. It is accomplished with narrow, yet deep mast rails; maintaining strength and capacity without unnecessarily obstructing the view.

Performance

Powerful dual-drive motors allow fast travel speeds, but even more important, fast acceleration. This unique drive motor arrangement lets the trucks negotiate railroad crossings, curbs, ramps and other obstacles with ease.

Operator Comfort

Consistent, high level of performance and efficiency, especially for extended periods of time, are only possible when the operator feels comfortable with the machine. The ergonomic layout of all controls, adjustability of armrest and seat, combined with low noise levels, provide the best possible operating environment.

ELEVEX™
Material Handling Solutions

Linde Material Handling *Linde*

Reliability

Reliability and durability are Linde design objectives. All components and assemblies are tested to meet rigorous longevity standards. During truck operation, dual electronic circuits monitor all systems to ensure flawless performance. This quality is demonstrated in 1000 hours of periodic maintenance intervals.

Productivity

Effective and efficient, the unique Linde energy management system ensures optimal performance and unmatched energy utilization. Uptime is achieved through the use of highly reliable components, a superb level of comfort for the driver and robust truck design features.

Technical Data

April 2016

SERIES 1276

SERIES 1276 (E25S, E25SH, E30S, E30SH, E35SH)

		Characteristics					
		Linde	Linde	Linde	Linde	Linde	
1.1	Manufacturer	Linde	Linde	Linde	Linde	Linde	
1.2	Model	E25S	E25SH	E30S	E30SH	E35SH	
1.3	Power	Electric	Electric	Electric	Electric	Electric	
1.4	Operation	Seated	Seated	Seated	Seated	Seated	
1.5	Capacity	Q lb (kg)	5000 (2500)	5000 (2500)	6000 (3000)	7000 (3500)	
1.6	Load center	c in (mm)	24 (500)	24 (500)	24 (500)	24 (500)	
1.8	Front overhang	x in (mm)	17.6 (447)	17.6 (447)	17.7 (450)	17.9 (455)	
1.9	Wheelbase	y in (mm)	67.7 (1720)	67.7 (1720)	67.7 (1720)	67.7 (1720)	
2.1	Weight	lb (kg)	9947 (4512)	11161 (5063)	10771 (4886)	11807 (5356)	12328 (5592)
2.2.1	Axle loading, laden front	lb (kg)	13677 (6204)	14457 (6558)	15529 (7044)	15919 (7221)	17864 (8103)
2.2.2	Axle loading, laden rear	lb (kg)	1781 (808)	2215 (1005)	1856 (842)	2504 (1136)	2180 (989)
2.3.1	Axle loading, empty front	lb (kg)	5132 (2328)	5582 (2532)	5264 (2388)	5690 (2581)	5866 (2661)
2.3.2	Axle loading, empty rear	lb (kg)	4814 (2184)	5579 (2531)	5507 (2498)	6117 (2775)	6461 (2931)
3.1	Tires		SE	SE	SE	SE	SE
3.2	Tire size, front (x=driven)	in (mm)	23x9-10	23x9-10	23x9-10	23x9-10	315x45-12
3.3	Tire size, rear		200/50-10	200/50-10	200/50-10	200/50-10	200/50-10
3.5.1	Number of wheels, front		2x	2x	2x	2x	2x
3.5.2	Number of wheels, rear		2	2	2	2	2
4.1.1	Tilt forward	deg	5°	5°	5°	5°	5°
4.1.2	Tilt backward	deg	5°	5°	5°	5°	5°
4.2	Height closed	h1 in (mm)	Chart	Chart	Chart	Chart	Chart
4.3	Free lift	h2 in (mm)	Chart	Chart	Chart	Chart	Chart
4.4	Lift height	h3 in (mm)	Chart	Chart	Chart	Chart	Chart
4.5	Mast height, raised	h4 in (mm)	Chart	Chart	Chart	Chart	Chart
4.7	Cab height	h6 in (mm)	81.1 (2085)	88.3 (2242)	81.1 (2085)	88.3 (2242)	88.3 (2242)
4.8	Seat height	h7 in (mm)	44.6 (1134)	50.8 (1291)	44.6 (1134)	50.8 (1291)	50.8 (1291)
4.12	Tow pin height	h10 in (mm)	25.8 (654)	26.5 (674)	25.8 (654)	26.5 (674)	26.5 (674)
4.19	Overall length	l1 in (mm)	134.9 (3427)	134.9 (3427)	135 (3430)	135 (3430)	135.3 (3435)
4.20	Length to fork face	l2 in (mm)	95.6 (2427)	95.6 (2427)	95.7 (2430)	95.7 (2430)	95.9 (2435)
4.21	Overall width	b1 in (mm)	46.3 (1175)	48.4 (1228)	48.4 (1228)	48.4 (1228)	52.2 (1325)
4.23	Type carriage		class 2	class 2	class 3	class 3	class 3
4.24	Carriage width	b3 in (mm)	45.3 (1150)	45.3 (1150)	45.3 (1150)	45.3 (1150)	45.3 (1150)
4.31	Ground clearance, mast	m1 in (mm)	4.8 (123)	4.8 (123)	4.8 (123)	4.8 (123)	4.8 (123)
4.32	Ground clearance, chassis	m2 in (mm)	4.8 (123)	4.8 (123)	4.8 (123)	4.8 (123)	4.8 (123)
4.33	Aisle width, with loa	Ast in (mm)	193.3 (4910)	193.3 (4910)	193.3 (4910)	193.3 (4910)	193.3 (4910)
4.34	Aisle width, add load	Ast in (mm)	137.4 (3490)	137.4 (3490)	137.4 (3490)	137.4 (3490)	137.4 (3490)
4.35	Outer turning radius	Wa in (mm)	78.2 (1986)	78.2 (1986)	78.2 (1986)	78.2 (1986)	78.2 (1986)
4.36	Inner turning radius	b13 in (mm)	3 (75)	3 (75)	3 (75)	3 (75)	3 (75)
5.1.1	Travel speed, laden	mph (kmh)	12.4 (20)	12.4 (20)	12.4 (20)	12.4 (20)	12.4 (20)
5.1.2	Travel speed, empty	mph (kmh)	12.4 (20)	12.4 (20)	12.4 (20)	12.4 (20)	12.4 (20)
5.2.1	Lift speed laden	fpm (m/s)	86 (0.44)	86 (0.44)	82 (0.42)	80 (0.42)	76 (0.39)
5.2.2	Lift speed empty	fpm (m/s)	100 (0.51)	100 (0.51)	100 (0.51)	100 (0.51)	100 (0.51)
5.3.1	Lowering speed laden	fpm (m/s)	110 (0.56)	110 (0.56)	110 (0.56)	110 (0.56)	110 (0.56)
5.3.2	Lowering speed empty	fpm (m/s)	96 (0.49)	96 (0.49)	96 (0.49)	96 (0.49)	96 (0.49)
5.5.1	Drawbar pull, laden (60 min)	lbf (N)	1237 (5500)	1303 (5800)	1371 (6100)	1618 (7200)	1596 (7100)
5.5.2	Drawbar pull, empty (60 min)	lbf (N)	1348 (6000)	1506 (6700)	1551 (6900)	1731 (7700)	1506 (6700)
5.6.1	Max drawbar, pull laden (5 min)	lbf (N)	3372 (15000)	3372 (15000)	3372 (15000)	3372 (15000)	3372 (15000)
5.6.2	Max drawbar, pull empty (5 min)	lbf (N)	2472 (11000)	2472 (11000)	2472 (11000)	2472 (11000)	2472 (11000)
5.7.1	Gradeability, laden (30 min)	%	8	8	8	8	8
5.7.2	Gradeability, empty (30 min)	%	13.7	13.7	13.7	13.7	12
5.8.1	Max gradeability, laden (5 min)	%	22	20	18	20	17
5.8.2	Max gradeability, empty (5 min)	%	28	25	25	25	25
5.9.1	Acceleration time, laden	s	6.1	6.5	6.5	6.5	6.7
5.9.2	Acceleration time, empty	s	5.8	5.9	5.9	5.9	5.9
5.10	Brakes		Hydraulic/Electric	Hydraulic/Electric	Hydraulic/Electric	Hydraulic/Electric	Hydraulic/Electric
6.1	Drive motor	hp (kw)	2x12 (2x9)	2x12 (2x9)	2x12 (2x9)	2x12 (2x9)	2x12 (2x9)
6.2	Lift motor	hp (kw)	22.8 (17)	22.8 (17)	22.8 (17)	22.8 (17)	22.8 (17)
6.3	Battery compartment size	in	40.7x33.9x25	40.7x33.9x31.3	40.7x33.9x25	40.7x33.9x31.3	40.7x33.9x31.3
6.4	Voltage	v	80	80	80	80	80
6.5	Battery weight (+/- 5%)	kg	3214 (1458)	4107 (1863)	3214 (1458)	4107 (1863)	4107 (1863)
8.1	Travel control		Microprocessor	Microprocessor	Microprocessor	Microprocessor	Microprocessor
8.2	Operating pressure	psi	185	185	210	210	210
8.3	Oil flow	g/m (l/m)	8.45 (32)	8.45 (32)	8.45 (32)	8.45 (32)	8.45 (32)
8.4	Noise level	db (A)	65	65	65	65	65

3

1

2

4

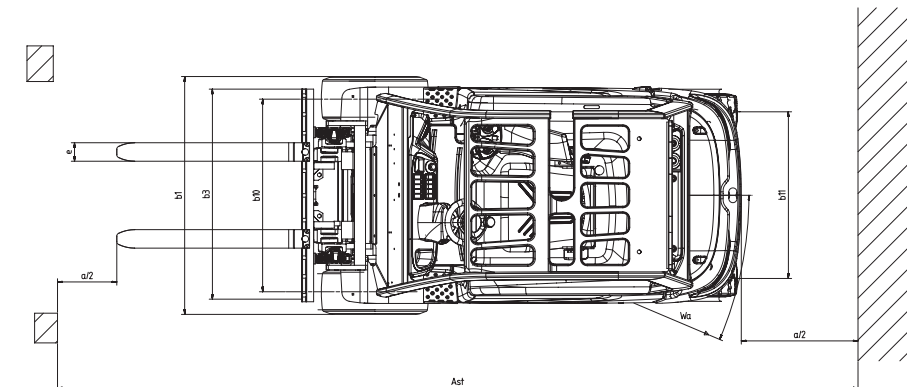
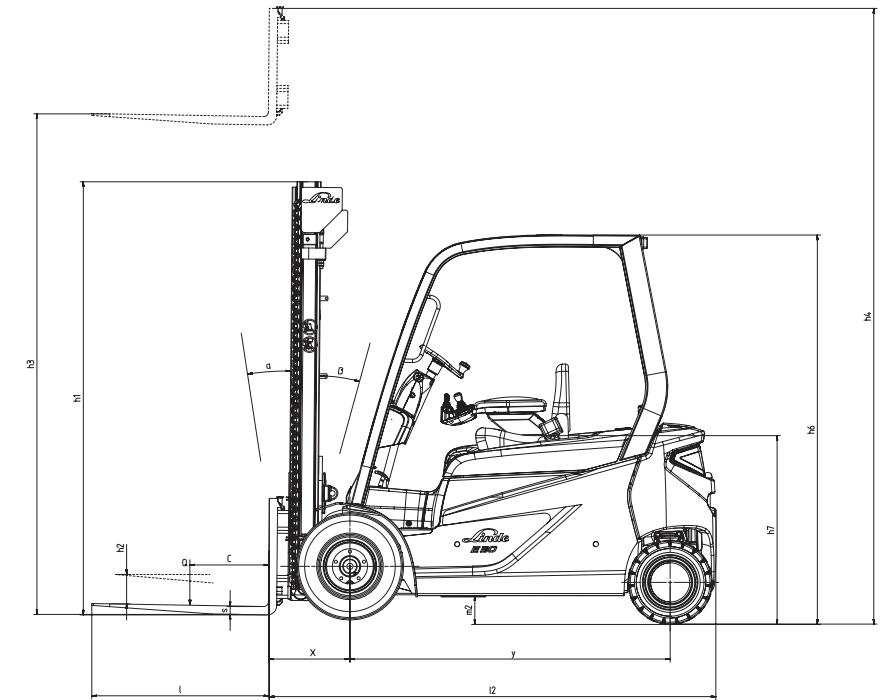

Notes

- 1) With 48-inch long load, including 4-inch operational clearance
- 2) Add load length and operational clearance
- 3) Including battery
- 4) Plus / minus 5%

Features

Linde Drive Axle

- Dual-drive motor design
- Maintenance-free service breaks
- Exceptionally energy efficient



Linde Operator Compartment

- Ergonomically designed
- Spacious foot room
- Armrest with operational controls
- Flip-up armrest

Linde Dual Pedal Travel Control

- Smooth directional changes
- Increased productivity
- Low fatigue operation
- Exceptionally precise travel control

Linde Load Control (LLC)

- Individual levers
- Precise and effortless operation
- Safe and highly-efficient load handling

Linde Mast Design

- High-strength, narrow mast profiles
- Ideal visibility with nested rails
- Nested lift cylinders, behind mast rails



Linde Drive Axle

- Electric differential function
- Electronic curve assist
- Traction control

Flexible Battery Handling

- 180-degree opening door
- Side discharge with crane or pickup with forks
- Easy-to-reach quick disconnect button

Linde Combi-Axle

- Highly stable configuration
- Excellent maneuverability
- Impressive residual capacity

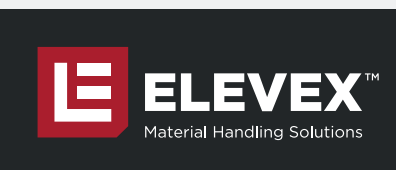

MONTREAL (Head office)

19151 A, Cruickshank Avenue
Baie-D'Urfé (Québec) H9X 3N9
Phone: 418 694-4223
Toll free: 1 866 421-4223
info@elevex.ca
elevex.ca

QUEBEC

1279, Paul-Émile Giroux St. Suite
200 Québec (Québec) G1C 0K9

SAGUENAY

2305, Alexis-Le-Trotteur
St. Jonquière (Québec) G7X 9H8

Linde Material Handling



ANSI: Standard truck meets all applicable mandatory requirements of ANSI/ITSDF B56.1 standards for powered industrial trucks.
NOTE: Performance data may vary due to motor and system efficiency tolerances. The performance depicted represents nominal values obtained under typical operating conditions. Metric dimensions are in millimeters unless otherwise specified. All metric dimensions are not direct equivalents due to rounding data. The descriptions and specifications included on this data sheet were in effect at the time of printing. Linde Material Handling North America Corporation reserves the right to make improvements and changes in specification or design without notice and without incurring obligation. Please check with your authorized Linde dealer for information on possible updates or revisions.