



Linde Material Handling

Linde



Electric Counterbalance Truck

X20 - X35

4,400 - 7,000 lb. Capacity

Series 1252

- The first electric forklift truck which combines the performance and durability of an IC truck with dynamics, flexibility, and freedom from emissions that comes with a Linde Li-ION electric forklift truck.
- Synchronous reluctance motor (SRM+) with efficient water-cooling system that allows for top-performance in multishift applications, even in extreme conditions like heavy debris and steep ramps.
- Highest standards when it comes to efficiency, ergonomics, and safety
- Wireless truck data transmission assists with fleet management programs
- Data transmission comes standard and has the ability to be embedded within digital logistic processes.

STANDARD & OPTIONAL EQUIPMENT

		X 20 - X 35
Operator assistance	Linde Curve Assist - automatic drive speed reduction when cornering	●
	Electrical seat belt monitoring - Visual and acoustic feedback	●
	Linde Load Assist - increased safety at high lift heights	●
	BlueSpot and TruckSpot - optical warning signal for pedestrians and drivers	○
	Load weight indicator	○
	Speed limitations	○
	Restraint systems (different options)	○
	Lighting: LED Stripes	○
	Lighting: VertiLight	○
	Linde Connect.Desk - local fleet management & telemetry	○
Digitalization	Pre-Operation Checklist - individualized daily protocol	○
	Impact sensing & reporting	○
	Data transmission via Wi-Fi or cellular	○
	Linde Guardian - pedestrian awareness and zone speed control	○
	Double pedal control - stepless acceleration and fast reversing	●
Operation/ Load Handling	Single pedal control - stepless acceleration	○
	Linde Load Control - individual electronic control levers fully integrated in the armrest of precise control of all hydraulic functions	●
	Central, multi-axis control joysticks	○
	Innovative decoupling concept with ring bearings for lowest human vibrations	●
	Ergonomic and safe truck access due to a low entry step and handle bar at front pillar	●
	Innovative decoupling concept for lowest human vibration	●
	Tilt adjustable steering column	●
	Overhead guard comfort for maximum head clearance	●
	Operator's seat - mechanical quick weight adjustment	●
	Various seating options such as heating, air suspension, active seat ventilation, longitudinal suspension	○
Workplace	Operator's seat - Swiveling seat	○
	Color 3.5" LED display with steering angle indicator, tilt angle indicator and remaining travel indicator	●
	Color 7" LED multifunction display integrates additional functions e.g. cameras	○
	Top screen armored glass	○
	Alloy doors with openable window and door monitoring	○
	Illuminated clipboard	○
	Fully integrated heater	○
	Fully integrated air conditioning with defog function	○
	Top mounted tilting cylinders - including maintenance free bearings	●
	Best visibility through asymmetric, nested mast profiles on standard, duplex, triplex mast	●
Mast	Electronic damped tilt stop	●
	Hydraulic accumulator for high driving comfort and less wear	○
	Integrated sideshift with full lift capacity	○
Forks	Integrated fork positioner "view" for high residual capacities and optimized visibility	○
	Super Elastic (SE) tyres	●
Axles & Tyres	Closed Shoulder Tyres CS 20	○
	Pneumatic tyres	○
	Antistatic, non marking tyres	○
	Anti-spray mudflaps front and rear	○
	Two motor front wheel drive	●
Drive System	Synchronous reluctance motor for lift and drive function	●
	Power setting efficiency, economy, performance	●
	Automatic parking brake	●

● Standard equipment ○ Optional equipment

ANSI: Standard truck meets all applicable mandatory requirements of ANSI/ISO B564 standards for powered industrial trucks.
 NOTE: Performance data may vary due to motor and system efficiency tolerances. The performance depicted represents nominal values obtained under typical operating conditions. Metric dimensions are in millimeters unless otherwise specified. All metric dimensions are not direct equivalents due to rounding data. The descriptions and specifications included on this data sheet were in effect at the time of printing. ICON North America Corporation reserves the right to make improvements and changes in specification or design without incurring obligation. Please check with your authorized dealer for information on possible updates or revisions.

X20 - X35 TECHNICAL DATA

			X20 / 600		X25		
Characteristics	1.1	Manufacturer	LINDE		LINDE		
	1.2	Manufacturer's type designation	X20 / 600		X25		
	1.2a	Series	1252		1252		
	1.3	Power unit	Battery		Battery		
	1.4	Operation	Seat		Seat		
	1.5	Load capacity/Load	Q (lb) (t)	4,400	2.0	5,000	2.5
	1.6	Load centre distance	c (in) (mm)	24	600	24	500
	1.8	Axle centre to fork face	x (in) (mm)	17.9	455	17.9	455
	1.9	Wheelbase	y (in) (mm)	72.2	1835	72.2	1853
Weights	2.1	Service weight	(lb) (kg)	10,663 ¹⁾	4837 ¹⁾	10,663 ¹⁾	4837 ¹⁾
	2.2	Axle load with load, front/rear	(lb) (kg)	12,484 / 2,588	5663/1174	13,922 / 2,253	6315 / 1022
	2.3	Axle load without load, front/rear	(lb) (kg)	5,540 / 5,123 ¹⁾	2513/2324 ¹⁾	5,540 / 5,123 ¹⁾	2513 / 2324 ¹⁾
Wheels/Tyres	3.1	Tyres rubber, SE, pneumatic, polyurethane	SE		SE		
	3.2	Tyre size, front	250 / 75-12 (27x10-12)		250 / 75-12 (27x10-12)		
	3.3	Tyre size, rear	6.50-10		6.50-10		
	3.5	Wheels, number front/rear (x = driven)	2x / 2		2x / 2		
	3.6	Track width, front	b10 (in) (mm)	39.7	1008	39.7	1008
	3.7	Track width, rear	b11 (in) (mm)	37.2	946	37.2	946
	Dimensions	4.1	Mast/fork carriage tilt, forward/backward	a/b (°)	5.0 / 8.0		5.0 / 8.0
4.2		Height of mast, lowered	h1 (in) (mm)	85.7	2220	85.7	2220
4.3		Free lift	h2 (in) (mm)	54.9	150	54.9	150
4.4		Lift	h3 (in) (mm)	184.3	3095	184.3	3095
4.5		Height of mast, extended	h4 (in) (mm)	215.0	3852	215.0	3852
4.7		Height of overhead guard (cabin)	h6 (in) (mm)	87.6	2225	87.6	2225
4.8		Seat height relating to SIP/stand height	h7 (in) (mm)	45.5	1156	45.5	1156
4.12		Towing coupling height	h10 (in) (mm)	231	587	231	587
4.19		Overall length	l1 (in) (mm)	144.5	3671	144.5	3671
4.20		Length to fork face	l2 (in) (mm)	105.2	2671	105.2	2671
4.21		Overall width	b1/b2 (in) (mm)	49.5 / 45.7	1256	49.5 / 45.7	1256
4.22		Fork dimensions	s / e / l (in) (mm)	1.8 x 4.0 x 40.0	45 x 100 x 1000	1.8 x 4.0 x 40.0	45 x 100 x 1000
4.23		Fork carriage type		2A		2A	
4.24		Width of fork carriage	b3 (in) (mm)	45.3	1150	45.3	1150
4.31		Ground clearance, below mast	m1 (in) (mm)	4.7	119	4.7	119
4.32		Ground clearance, centre of wheelbase	m2 (in) (mm)	6.8	173	6.8	173
4.34.1		Aisle width for pallets 1000 x 1200 crossways	Ast (in) (mm)	157.8 ²⁾	4008 ²⁾	157.8 ²⁾	4008 ²⁾
4.34.2		Aisle width with pallet 800 x 1200 along forks	Ast (in) (mm)	165.7 ²⁾	4208 ²⁾	165.7 ²⁾	4208 ²⁾
4.35		Turning radius	Wa (in) (mm)	92.6	2352	92.6	2352
4.36		Minimum pivoting point distance	b13 (in) (mm)	25.8	655	25.8	655
Performance		5.1	Travel speed, with/without load	(mph) (km/h)	13.7 / 13.7	22 / 22	13.7 / 13.7
	5.2	Lifting speed, with/without load	(fpm) (m/s)	110 / 114	0.56 / 0.58	110 / 114	0.57 / 0.58
	5.3	Lowering speed, with/without load	(fpm) (m/s)	114 / 112	0.58 / 0.57	114 / 112	0.58 / 0.57
	5.5	Tractive force, with/without load	(lbf) (N)	1,708 / 1,708	7600 / 7600	1,708 / 1,708	7600 / 7600
	5.6	Maximum tractive force, with/without load	(lbf) (N)	4,496 / 4,496	20000 / 20000	4,496 / 4,496	20000 / 20000
	5.7	Climbing ability, with/without load	%	22.2 / 33.2		20.5 / 33.2	
	5.8	Maximum climbing ability, with/without load	%	28.7 / 43.4		26.4 / 43.4	
	5.9	Acceleration time, with/without load	s	4.8 / 4.3		4.9 / 4.3	
	5.10	Service brake		hydr./mech.		hydr./mech.	
	Drive	6.1	Drive motor rating S2 60 min	(kW)	2x 12.4		2x 12.4
6.2		Lift motor rating at S3 15%	(kW)	20		20	
6.3		Battery Type		Li-ION		Li-ION	
6.4		Battery voltage/rated capacity (5h)	(V)/(Ah) (kWh)	90 / 670	60.3	90 / 670	60.3
6.6		Energy consumption according to DIN EN 16796	kWh/h	6.1		6.5	
6.6.1		CO2 equivalent according to EN 16796	(lb/h) (kg/h)	7.3	3.3	7.7	3.5
Others	8.1	Type of drive unit		Digital/stepless		Digital/stepless	
	10.1	Operating pressure for attachments	(psi) (bar)	2,600	180	2,900	200
	10.2	Oil flow for attachments	(gpm) (l/min)	13	50	13	50
	10.7	Sound pressure level LpAZ (at the driver's seat)	dB(A)	<65		<65	

1) Figures with battery, see line 6.4. 2) Including a 8" operating aisle clearance.

NOTICE: Products are subject to change without notice. Our products are continuously being improved, all conditions, terms, and specifications are subject to change at any time.

X20 - X35 TECHNICAL DATA

Characteristics	1.1	Manufacturer		LINDE	LINDE
	1.2	Manufacturer's type designation		X30	X35
	1.2a	Series		1252	
	1.3	Power unit		Battery	Battery
	1.4	Operation		Seat	Seat
	1.5	Load capacity/Load	Q (lb) (t)	6,000 3.0	7,000 3.5
	1.6	Load centre distance	c (in) (mm)	24 500	24 500
	1.8	Axle centre to fork face	x (in) (mm)	17.7 448	17.9 453
	1.9	Wheelbase	y (in) (mm)	73.8 1875	73.8 1875
Weights	2.1	Service weight	(lb) (kg)	11,289 ¹⁾ 5121 ¹⁾	12,204 ¹⁾ 5536 ¹⁾
	2.2	Axle load with load, front/rear	(lb) (kg)	15,661 / 2,242 7104 / 1017	17,533 / 2,387 7953 / 1083
	2.3	Axle load without load, front/rear	(lb) (kg)	5,701 / 5,588 ¹⁾ 2568 / 2535 ¹⁾	5,893 / 6,311 ¹⁾ 2673 / 2863 ¹⁾
Wheels/Tyres	3.1	Tyres rubber, SE, pneumatic, polyurethane		SE	SE
	3.2	Tyre size, front		250 / 75-12 (27x10-12)	355 / 45-15 (28x12.5-15)
	3.3	Tyre size, rear		225 / 75-10 (23x9-10)	225 / 75-10 (23x9-10)
	3.5	Wheels, number front/rear (x = driven)		2x / 2	2x / 2
	3.6	Track width, front	b10 (in) (mm)	39.7 1008	41.7 1060
	3.7	Track width, rear	b11 (in) (mm)	36.6 930	36.6 930
Dimensions	4.1	Mast/fork carriage tilt, forward/backward	a/b (°)	5.0 / 8.0	5.0 / 8.0
	4.2	Height of mast, lowered	h1 (in) (mm)	85.7 2218	85.7 2224
	4.3	Free lift	h2 (in) (mm)	54.9 150	54.9 150
	4.4	Lift	h3 (in) (mm)	184.3 3095	184.3 3856
	4.5	Height of mast, extended	h4 (in) (mm)	215.0 3850	215.0 3856
	4.7	Height of overhead guard (cabin)	h6 (in) (mm)	87.6 2225	87.6 2225
	4.8	Seat height relating to SIP/stand height	h7 (in) (mm)	45.8 1162	45.8 1162
	4.12	Towing coupling height	h10 (in) (mm)	23.5 598	23.6 600
	4.19	Overall length	l1 (in) (mm)	145.8 3704	146.0 3709
	4.20	Length to fork face	l2 (in) (mm)	106.5 2704	106.7 2709
	4.21	Overall width	b1/b2 (in) (mm)	49.5 / 45.7 1256	53.4 / 45.7 1356
	4.22	Fork dimensions	s / e / l (in) (mm)	1.8 x 4.0 x 40.0 45 x 100 x 1000	2.0 x 5.0 x 40.0 50 x 120 x 1000
	4.23	Fork carriage type		3A	3A
	4.24	Width of fork carriage	b3 (in) (mm)	45.3 1150	45.3 1150
	4.31	Ground clearance, below mast	m1 (in) (mm)	4.6 117	4.9 124
	4.32	Ground clearance, centre of wheelbase	m2 (in) (mm)	7.0 178	7.1 180
	4.34.1	Aisle width for pallets 1000 x 1200 crossways	Ast (in) (mm)	159.2 ²⁾ 4043 ²⁾	1159.4 ²⁾ 4048 ²⁾
	4.34.2	Aisle width with pallet 800 x 1200 along forks	Ast (in) (mm)	167.1 ²⁾ 4243 ²⁾	167.2 ²⁾ 4248 ²⁾
	4.35	Turning radius	Wa (in) (mm)	94.3 2394	94.3 2394
4.36	Minimum pivoting point distance	b13 (in) (mm)	26.3 668	26.3 668	
Performance	5.1	Travel speed, with/without load	(mph) (km/h)	13.7 / 13.7 22 / 22	13.7 / 13.7 22 / 22
	5.2	Lifting speed, with/without load	(fpm) (m/s)	112 / 114 0.57 / 0.58	106 / 114 0.54 / 0.58
	5.3	Lowering speed, with/without load	(fpm) (m/s)	114 / 112 0.58 / 0.57	114 / 112 0.58 / 0.57
	5.5	Tractive force, with/without load	(lbf) (N)	1,708 / 1,708 7600 / 7600	1,708 / 1708 7600 / 7600
	5.6	Maximum tractive force, with/without load	(lbf) (N)	4,496 / 4,496 20000 / 20000	4,496 / 4,496 20000 / 20000
	5.7	Climbing ability, with/without load	%	18.3 / 31.2	17.6 / 27.2
	5.8	Maximum climbing ability, with/without load	%	23.6 / 40.6	19.9 / 35.3
	5.9	Acceleration time, with/without load	s	5.1 / 4.3	5.3 / 4.4
	5.10	Service brake		hydr./mech.	hydr./mech.
	Drive	6.1	Drive motor rating S2 60 min	(kW)	2x 12.4
6.2		Lift motor rating at S3 15%	(kW)	20	20
6.3		Battery type		Li-ION	Li-ION
6.4		Battery voltage/rated capacity (5h)	(V)/(Ah) (kWh)	90 / 670 60.3	90 / 670 60.3
6.6		Energy consumption according to DIN EN 16796	kWh/h	7	7.3
6.6.1		CO2 equivalent according to EN 16796	(lb/h) (kg/h)	8.4 3.8	8.6 3.9
Others		8.1	Type of drive unit		Digital/stepless
	10.1	Operating pressure for attachments	(psi) (bar)	2900 225	3,500 245
	10.2	Oil flow for attachments	(gpm) (l/min)	13 50	13 50
	10.7	Sound pressure level LpAZ (at the driver's seat)	dB(A)	<65	<65

1) Figures with battery, see line 6.4. 2) Including a 8" operating aisle clearance.

NOTICE: Products are subject to change without notice. Our products are continuously being improved, all conditions, terms, and specifications are subject to change at any time.

X20 - X35 TECHNICAL DATA

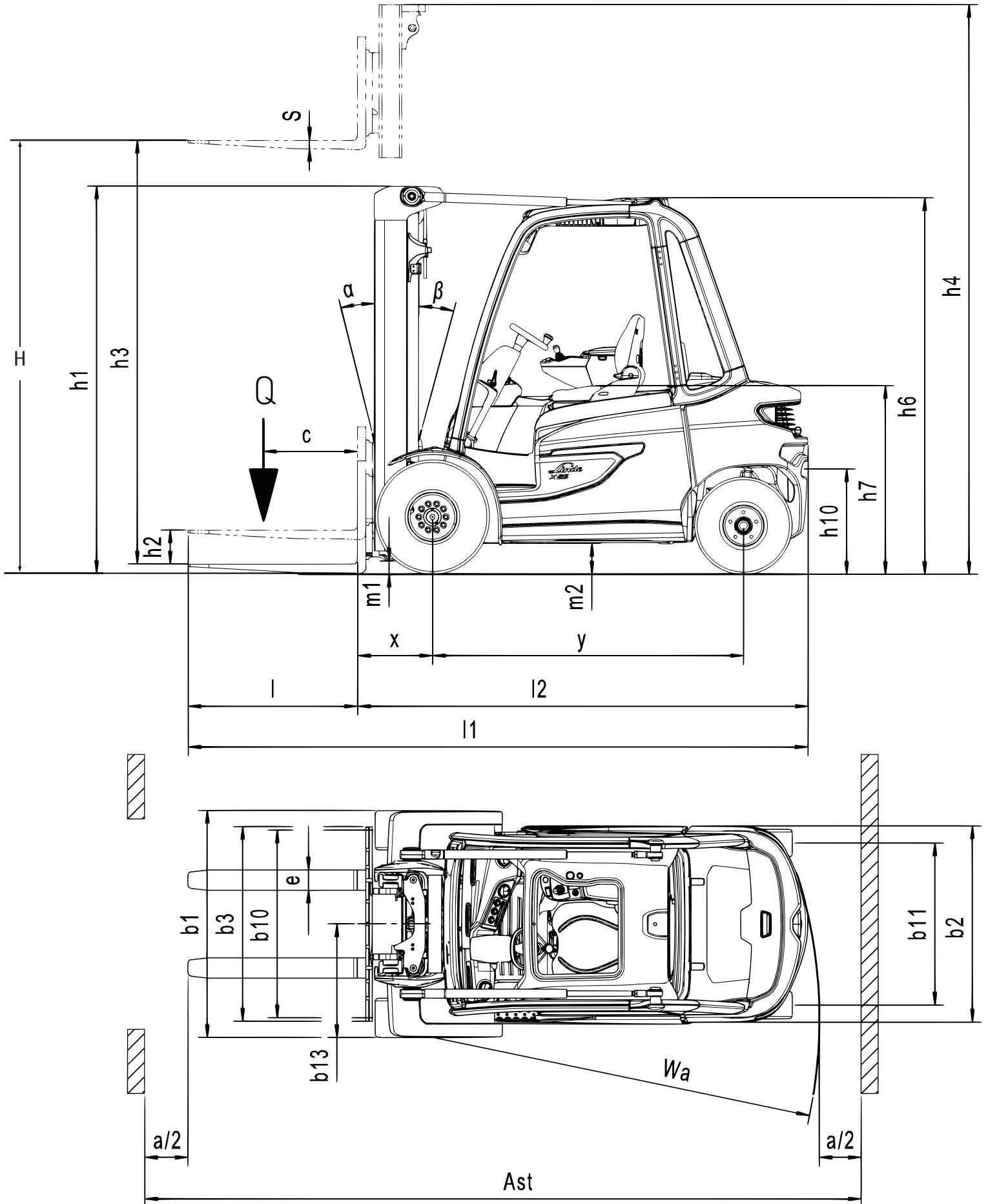

*Refer to Technical Data Chart

MAST TABLES

STANDARD MAST (in)

Series	1533							
Lift	H: 121.9	H: 129.7	H: 133.7	H: 145.7	H: 157.3	H: 165.2	H: 177.0	
Height Measurements	h1: 87.6 h2: 5.9 h4: 151.8	h1: 91.5 h2: 5.9 h4: 159.7	h1: 93.5 h2: 5.9 h4: 163.6	h1: 99.4 h2: 5.9 h4: 175.4	h1: 105.3 h2: 5.9 h4: 187.2	h1: 109.3 h2: 5.9 h4: 195.1	h1: 115.2 h2: 5.9 h4: 206.9	
Model								
X20 / 600	<input type="radio"/>	<input type="radio"/>	<input type="radio"/>	<input type="radio"/>	<input type="radio"/>	<input type="radio"/>	<input type="radio"/>	
X25	<input type="radio"/>	<input type="radio"/>	<input type="radio"/>	<input type="radio"/>	<input type="radio"/>	<input type="radio"/>	<input type="radio"/>	
X30	<input type="radio"/>	<input type="radio"/>	<input type="radio"/>	<input type="radio"/>	<input type="radio"/>	<input type="radio"/>	<input type="radio"/>	
X35	<input type="radio"/>	<input type="radio"/>	<input type="radio"/>	<input type="radio"/>	<input type="radio"/>	<input type="radio"/>	<input type="radio"/>	
X20 / 600 Container	<input type="radio"/>	<input type="radio"/>	<input type="radio"/>	<input type="radio"/>	<input type="radio"/>	<input type="radio"/>	<input type="radio"/>	
X25 Container	<input type="radio"/>	<input type="radio"/>	<input type="radio"/>	<input type="radio"/>	<input type="radio"/>	<input type="radio"/>	<input type="radio"/>	
X30 Container	<input type="radio"/>	<input type="radio"/>	<input type="radio"/>	<input type="radio"/>	<input type="radio"/>	<input type="radio"/>	<input type="radio"/>	
X35 Container	<input type="radio"/>	<input type="radio"/>	<input type="radio"/>	<input type="radio"/>	<input type="radio"/>	<input type="radio"/>	<input type="radio"/>	

DUPLEX MAST (in)

Series	1533				
Lift	H: 124.6	H: 128.5	H: 132.5	H: 136.4	H: 148.2
Height Measurements	h1: 85.8 h2: 54.9 h4: 155.6	h1: 87.8 h2: 56.9 h4: 159.5	h1: 89.8 h2: 58.9 h4: 163.4	h1: 91.7 h2: 60.8 h4: 167.4	h1: 97.6 h2: 66.7 h4: 179.2
Model					
X20 / 600	<input type="radio"/>	<input type="radio"/>	<input type="radio"/>	<input type="radio"/>	<input type="radio"/>
X25	<input type="radio"/>	<input type="radio"/>	<input type="radio"/>	<input type="radio"/>	<input type="radio"/>
X30	<input type="radio"/>	<input type="radio"/>	<input type="radio"/>	<input type="radio"/>	<input type="radio"/>
X35	<input type="radio"/>	<input type="radio"/>	<input type="radio"/>	<input type="radio"/>	<input type="radio"/>
X20 / 600 Container	<input type="radio"/>	<input type="radio"/>	<input type="radio"/>	<input type="radio"/>	<input type="radio"/>
X25 Container	<input type="radio"/>	<input type="radio"/>	<input type="radio"/>	<input type="radio"/>	<input type="radio"/>
X30 Container	<input type="radio"/>	<input type="radio"/>	<input type="radio"/>	<input type="radio"/>	<input type="radio"/>
X35 Container	<input type="radio"/>	<input type="radio"/>	<input type="radio"/>	<input type="radio"/>	<input type="radio"/>

TRIPLEX MAST (in)

Series	1533															
Lift	H: 184.3	H: 190.2		H: 196.1		H: 202.0		H: 209.8		H: 215.7		H: 233.5		H: 259.1		
Height Measurements	h1: 85.8 h2: 54.9 h4: 215.5	h1: 87.8 h2: 56.9 h4: 221.4	h1: 89.8 h2: 58.9 h4: 227.3	h1: 91.7 h2: 60.8 h4: 233.2	h1: 95.7 h2: 64.8 h4: 241.1	h1: 97.6 h2: 66.7 h4: 247.0	h1: 103.5 h2: 72.6 h4: 264.7	h1: 109.3 h2: 78.5 h4: 282.4	h1: 115.2 h2: 84.4 h4: 299.1	h1: 121.1 h2: 90.3 h4: 315.8	h1: 127.0 h2: 96.2 h4: 332.5	h1: 132.9 h2: 102.1 h4: 349.2	h1: 138.8 h2: 108.0 h4: 365.9	h1: 144.7 h2: 114.0 h4: 382.6	h1: 150.6 h2: 119.9 h4: 399.3	h1: 156.5 h2: 125.8 h4: 416.0
Model																
X20 / 600	<input type="radio"/>	<input type="radio"/>	<input type="radio"/>	<input type="radio"/>	<input type="radio"/>	<input type="radio"/>	<input type="radio"/>	<input type="radio"/>	<input type="radio"/>	<input type="radio"/>	<input type="radio"/>	<input type="radio"/>	<input type="radio"/>	<input type="radio"/>	<input type="radio"/>	
X25	<input type="radio"/>	<input type="radio"/>	<input type="radio"/>	<input type="radio"/>	<input type="radio"/>	<input type="radio"/>	<input type="radio"/>	<input type="radio"/>	<input type="radio"/>	<input type="radio"/>	<input type="radio"/>	<input type="radio"/>	<input type="radio"/>	<input type="radio"/>	<input type="radio"/>	
X30	<input type="radio"/>	<input type="radio"/>	<input type="radio"/>	<input type="radio"/>	<input type="radio"/>	<input type="radio"/>	<input type="radio"/>	<input type="radio"/>	<input type="radio"/>	<input type="radio"/>	<input type="radio"/>	<input type="radio"/>	<input type="radio"/>	<input type="radio"/>	<input type="radio"/>	
X35	<input type="radio"/>	<input type="radio"/>	<input type="radio"/>	<input type="radio"/>	<input type="radio"/>	<input type="radio"/>	<input type="radio"/>	<input type="radio"/>	<input type="radio"/>	<input type="radio"/>	<input type="radio"/>	<input type="radio"/>	<input type="radio"/>	<input type="radio"/>	<input type="radio"/>	
X20 / 600 Container	<input type="radio"/>	<input type="radio"/>	<input type="radio"/>	<input type="radio"/>	<input type="radio"/>	<input type="radio"/>	<input type="radio"/>	<input type="radio"/>	<input type="radio"/>	<input type="radio"/>	<input type="radio"/>	<input type="radio"/>	<input type="radio"/>	<input type="radio"/>	<input type="radio"/>	
X25 Container	<input type="radio"/>	<input type="radio"/>	<input type="radio"/>	<input type="radio"/>	<input type="radio"/>	<input type="radio"/>	<input type="radio"/>	<input type="radio"/>	<input type="radio"/>	<input type="radio"/>	<input type="radio"/>	<input type="radio"/>	<input type="radio"/>	<input type="radio"/>	<input type="radio"/>	
X30 Container	<input type="radio"/>	<input type="radio"/>	<input type="radio"/>	<input type="radio"/>	<input type="radio"/>	<input type="radio"/>	<input type="radio"/>	<input type="radio"/>	<input type="radio"/>	<input type="radio"/>	<input type="radio"/>	<input type="radio"/>	<input type="radio"/>	<input type="radio"/>	<input type="radio"/>	
X35 Container	<input type="radio"/>	<input type="radio"/>	<input type="radio"/>	<input type="radio"/>	<input type="radio"/>	<input type="radio"/>	<input type="radio"/>	<input type="radio"/>	<input type="radio"/>	<input type="radio"/>	<input type="radio"/>	<input type="radio"/>	<input type="radio"/>	<input type="radio"/>	<input type="radio"/>	

○ Optional equipment

– Not available

h1: Height of mast, lowered

h2: Free lift

h3: lift

h4: Height of mast, extended

LOAD CAPACITY RATINGS

TRIPLEX MAST

X20 / 600

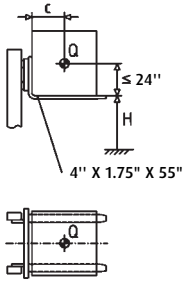

H (in)	Q (lb)			
315	1980	1800	1650	1540
307	2270	2070	1910	1760
299	2570	2350	2150	2000
291	2880	2620	2420	2680
283	3190	2900	2660	2460
276	2480	3190	2930	2710
272	3630	3320	3060	2820
268	3790	3460	3190	2950
264	3940	3590	3320	3060
260	4090	3740	3590	3110
256	4250	3870	3740	3300
≤ 252	4400	4000	3700	3410
c (in)	≤ 24	28	32	36

X25

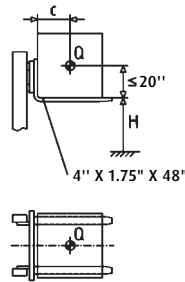

H (in)	Q (lb)			
315	1980	1780	1630	1490
303	2420	2200	2000	1850
291	2880	2620	2380	2200
283	3190	2880	2640	2420
276	3500	3170	2880	2660
268	3810	3460	3150	2900
260	4120	3720	3390	3120
252	4430	4010	3650	3370
244	4730	4270	3900	3590
236	5040	4560	4160	3830
228	5350	4840	4400	4050
≤ 224	5510	5000	4540	4180
c (in)	16-20	24	28	32

X30

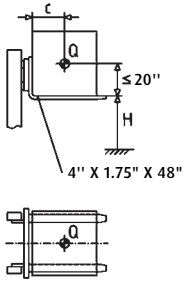

H (in)	Q (lb)			
315	2420	2180	1980	1820
299	3080	2770	2530	2330
283	3740	3370	3080	2840
276	4070	3680	3350	3080
268	4400	3960	3630	3320
260	4730	4270	3900	3590
252	5060	4580	4160	3830
244	5390	4870	4450	4090
236	5730	5170	4710	4340
228	6080	5480	5000	4000
220	6430	5810	5310	4870
≤ 217	6610	6000	5440	5000
c (in)	16-20	24	28	32

X35

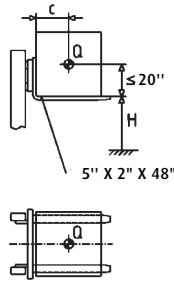

H (in)	Q (lb)			
315	2420	2180	1980	1820
299	3080	2770	2530	2330
283	3740	3370	3080	2840
268	4400	3980	3630	3350
260	4730	4270	3900	2590
252	5060	4580	4180	3830
244	5390	4870	4450	4090
236	5730	5170	4710	4340
228	6210	5620	5130	4710
220	6720	6080	5550	5110
213	7200	6520	5950	5480
208	7710	7000	6360	5860
c (in)	16-20	24	28	32

H= Lifting height C= Load center Q= Load capacity
Load capacity for triplex mast and fork carriage

CHARACTERISTICS



Driver workplace

Ergonomics

- Spacious driver's cab and ergonomic seat ensure fatigue-free working
- Optimum view of both the load and surroundings
- Layout of control elements reduces the physical strain on the driver
- Separation of the workstation, mast, and drive and steering axles reduces physical strain on the operator when driving over rough terrain



Handling

- A longer wheelbase, large tires, and vibration-free drive axle enable use in challenging environments
- Synchronous reluctance motors (SRM+) for lift and drive function with efficient water-cooling system ensures consistently high performance, even in extreme conditions
- Overhead tilt cylinder and warp-resistant mast design ensure safe load handling, even when storing and retrieving at height



All-round visibility

Safety

- Chassis, A-pillar, mast, and roof construction provide the driver with optimum visibility of the load and surroundings
- The truck's low center of gravity reduces the risk of tipping
- Linde Curve Assist reduces speed in relation to the steering angle when cornering
- Linde Load Assist reduces the risk of tipping accidents when moving loads at height
- Automatic parking brake and ramp-hold function



Service

- Long service intervals e.g. 6000 h/3 years hydraulic oil/filter change
- Easy access to main components
- Driver display shows all important truck information to the driver
- Remote fault diagnosis and firmware updates can be conducted without a service technician; resulting in lower operating costs
- Modular assemblies allow for quick replacement, shortening downtime during repairs



MONTREAL (Head office)

19151 A, Cruickshank Avenue
Baie-D'Urfé (Québec) H9X 3N9
Phone: 418 694-4223
Toll free: 1 866 421-4223
info@elevex.ca
elevex.ca

QUEBEC

1279, Paul-Émile Giroux St. Suite
200 Québec (Québec) G1C 0K9

SAGUENAY

2305, Alexis-Le-Trotteur
St. Jonquière (Québec) G7X 9H8



Member of KION Group