



Linde Material Handling

Linde



Electric Counterbalance Trucks

X35 – X50

Capacity 7,700 - 11,000 lb. | Series 1254

Powerful, highly energy-efficient truck

- Robust electric forklift truck with long wheelbase and high ground clearance ideal for intensive outdoor operating conditions
- High performance synchronous reluctance motors (SRM+) and water-cooled power modules for maximum performance under any load
- Intuitive operating controls, excellent visibility and ergonomic design ensures a high level of comfort and guarantees productive load handling
- Five models with a comprehensive range of equipment as standard as well as optional equipment for customising the truck to any application

STANDARD & OPTIONAL EQUIPMENT

	Model/truck equipment	X35 - X50
Operator's workstation	Innovative damping concept helps isolate operator's compartment from harmful vibrations	●
	Ergonomic and safe on/off access to the truck with low non-slip step and handles on the A-pillar and engine cover	●
	Steering wheel with tilt adjustment	●
	Comfort overhead guard for maximum headroom	●
	Operator's seat - quick, easy mechanical weight adjustment	●
	Different operator's seat options: Heated seats, air suspension, active seat suspension, fore/aft suspension	○
	Operator's seat - swivelling seat	○
	3.5" LED colour display including steering angle and tilt angle display	●
	7" LED multifunction colour display	○
	Armoured glass roof window	○
	Light metal doors with wide-opening window	○
	Document clipboard board with lighting	○
Fully integrated heating/air conditioning incl. Defrost	○	
Power unit and braking system	Twin motor front-wheel drive	●
	High performance synchronous reluctance motors (SRM+) for traction and lifting functions	●
	Operating settings - economy, efficiency and performance - for individual performance adjustment	●
	Automatic parking brake	●
Axles and tyres	Super-elastic (SE) tyres	●
	Closed shoulder CS 20 tyres	○
	Pneumatic tyres	○
	Anti-static tyres, non-marking	○
	Dirt deflectors/mud guards, front and rear	○
Mast	High mounted tilt cylinders - including maintenance-free bearings	●
	Optimum visibility due to asymmetric nested mast profiles on standard, duplex and triplex masts	●
	Electronically damped tilt stop	●
	Hydraulic accumulator for increased driving comfort, improved load protection and reduced wear and tear	○
Attachments /forks	Integrated roller-guided side shifter provides full nominal load capacity	○
	Integrated fork-positioning carriage "VIEW" for high residual load capacity and optimum visibility	○
Assistance	Linde Curve Assist - automatic reduction of travel speed around corners	●
	Electric seat belt monitoring - visual and audible feedback to ensure seat belt is correctly attached	●
	BlueSpot and TruckSpot - visual drive path warning for pedestrians and operators	○
	Load weight display	○
	Linde Guardian - audio-visual proximity warning truck-to-truck and between trucks and pedestrians	○
	Speed restriction options - via switch, indoor/outdoor, load- or lift height-dependent	○
	Various truck lighting options: Headlights, full road lighting, working lights, beacons, LED strips, VertiLights	○
Digitalisation	Online data transmission	●
	WiFi data transmission	○
	Linde connect:desk - local fleet management with different functional modules	○
	Linde connect:cloud - fleet management as a service (hosted version)	○
Operation/ load handling	Pre-Operation Check - customisable daily inspection log to check the readiness of the truck for operation	○
	Double pedal control - smooth acceleration and quick direction changes	●
	Single pedal control with direction selection switch - smooth acceleration and easy direction change	○
	Individual levers fully integrated into armrest for precise control of all hydraulic functions	●

● Standard equipment ○ Optional equipment

X35 – X50 TECHNICAL DATA

Characteristics	1.1	Manufacturer		LINDE	LINDE	LINDE
	1.2	Manufacturer type designation		X35/600	X40/600	X45/600
	1.2a	Series		1254	1254	1254
	1.3	Drive system		Linde Li-ION battery	Linde Li-ION battery	Linde Li-ION battery
	1.4	Operator type		Seat	Seat	Seat
	1.5	Rated capacity/rated load	Q (lb)	7,700	8,800	9,900
	1.6	Load center distance	c (in)	24	24	24
	1.8	Load distance, center of drive axle to fork	x (in)	20.7	21.1	21.1
	1.9	Wheelbase	y (in)	83.5	83.5	83.5
Weights	2.1	Service weight	lb	15,167 ¹⁾	15,251 ¹⁾	15,860 ¹⁾
	2.2	Axle loading, loaded front/rear	lb	19,539 / 3,344	21,382 / 2,687	23,060 / 2,720
	2.3	Axle loading, unloaded front/rear	lb	7,727 / 7,440	7,841 / 7,409	7,826 / 8,033
Wheels/Tyres	3.1	Tire type		Solid-pneumatic	Solid-pneumatic	Solid-pneumatic
	3.2	Tire size, front		315/70-15 (300-15)	315/70-15 (300-15)	315/70-15 (300-15)
	3.3	Tire size, rear		250/70-15 (250-15)	250/70-15 (250-15)	250/70-15 (250-15)
	3.5	Wheels, number front/rear (x = driven wheels)		2x / 2	2x / 2	2x / 2
	3.6	Tread width, front	b10 (in)	46.9	46.9	46.9
	3.7	Tread width, rear	b11 (in)	44.2	44.2	44.2
	Dimensions	4.1	Tilt range, forward/backward	α/β (°)	See table	See table
4.2		Height of mast, lowered	h1 (in)	See table	See table	See table
4.3		Free lift	h2 (in)	See table	See table	See table
4.4		Lift	h3 (in)	See table	See table	See table
4.5		Height, mast extended	h4 (in)	See table	See table	See table
4.7		Height of overhead guard	h6 (in)	98.2	98.2	98.2
4.8		Seat height	h7 (in)	54.2 / -	54.2 / -	54.2 / -
4.12		Coupling height	h10 (in)	28.2	28.2	28.1
4.19		Overall length	l1 (in)	172.9	172.9	172.9
4.20		Length to face of forks	l2 (in)	124.9	124.9	124.9
4.21		Overall width	b1/b2 (in)	57.0 / -	57.0 / -	57.0 / -
4.22		Fork dimensions	s / e / l (in)	2.0 x 5.0 x 48	2.0 x 5.0 x 48	2.0 x 5.0 x 48
4.23		Fork carriage type		3A	3A	3A
4.24		Fork carriage width	b3 (in)	53.2	53.2	53.2
4.31		Ground clearance, loaded, below mast	m1 (in)	8.1	8.1	8.1
4.32		Ground clearance, center of wheelbase	m2 (in)	9.6	9.6	9.6
4.34		Aisle width for pallets 40" x 48"	Ast (in)	188 ²⁾	189 ²⁾	189 ²⁾
4.35	Turning radius	Wa (in)	112	112	112	
4.36	Internal turning radius	b13 (in)	33.2	33.2	33.2	
Performance	5.1	Travel speed, loaded/unloaded	mph	13.7 / 13.7	13.7 / 13.7	13.7 / 13.7
	5.2	Lift speed, loaded/unloaded	fpm	116 / 118	110 / 118	102 / 118
	5.3	Lowering speed, loaded/unloaded	fpm	108 / 108	108 / 108	108 / 108
	5.5	Drawbar pull, loaded/unloaded	lbf	1,910 / 1,910	1,910 / 1,910	1,910 / 1,910
	5.6	Max. drawbar pull, loaded/unloaded	lbf	4,945 / 4,945	4,945 / 4,945	4,945 / 4,945
	5.7	Gradeability, loaded/unloaded	%	18 / 28	17 / 28	15 / 27
	5.8	Max. gradeability, loaded/unloaded	%	22 / 32	21 / 32	19 / 31
	5.9	Acceleration time, loaded/unloaded	s	5.3 / 4.6	5.4 / 4.6	5.5 / 4.7
	5.10	Service brake		hydr./mech.	hydr./mech.	hydr./mech.
	Drive	6.1	Drive motor rating S2 60 min	kW	2 x 15	2 x 15
6.2		Lift motor rating at S3 15%	kW	28	28	28
6.3		Battery type		Linde Li-ION	Linde Li-ION	Linde Li-ION
6.4		Battery specification; Size M	v / kWh	90 / 65.9	90 / 65.9	90 / 65.9
6.5		Battery weight (\pm 5%)	lb	3,214	3,214	3,214
6.7		CO2 equivalent according to DIN EN 16796	lb/hr	9.9	10.5	11.1
Others		10.1	Operating pressure for attachments	psi	2,466	2,466
	10.2	Oil volume for attachments	gpm	14.5	14.5	14.5
	10.7	Sound pressure level LpAZ (at the driver's seat)	dB(A)	67	67	67

1) Figures with battery

2) Including 8" operating aisle clearance.

X35 – X50 TECHNICAL DATA

Characteristics	1.1	Manufacturer		LINDE	LINDE
	1.2	Manufacturer type designation		X50/500	X50/600
	1.2a	Series		1254	1254
	1.3	Drive system		Linde Li-ION battery	Linde Li-ION battery
	1.4	Operator type		Seat	Seat
	1.5	Rated capacity/rated load	Q (lb)	10,000	11,000
	1.6	Load center distance	c (in)	20	24
	1.8	Load distance, center of drive axle to fork	x (in)	21.1	21.1
	1.9	Wheelbase	y (in)	83.5	83.5
Weights	2.1	Service weight	lb	15,807 ¹⁾	16,616 ¹⁾
	2.2	Axle loading, loaded front/rear	lb	24,114 / 2,694	24,709 / 2,907
	2.3	Axle loading, unloaded front/rear	lb	7,740 / 8,066	7,817 / 8,798
Wheels/Tires	3.1	Tire type		Solid-pneumatic	Solid-pneumatic
	3.2	Tire size, front		315/70-15 (300-15)	315/70-15 (300-15)
	3.3	Tire size, rear		250/70-15 (250-15)	250/70-15 (250-15)
	3.5	Wheels, number front/rear (x = driven wheels)		2x / 2	2x / 2
	3.6	Tread width, front	b10 (in)	46.9	46.9
3.7	Tread width, rear	b11 (in)	44.2	44.2	
Dimensions	4.1	Tilt range, forward/backward	α/β (°)	See table	See table
	4.2	Height of mast, lowered	h1 (in)	See table	See table
	4.3	Free lift	h2 (in)	See table	See table
	4.4	Lift	h3 (in)	See table	See table
	4.5	Height, mast extended	h4 (in)	See table	See table
	4.7	Height of overhead guard	h6 (in)	98.2	98.2
	4.8	Seat height	h7 (in)	54.2 / -	54.2 / -
	4.12	Coupling height	h10 (in)	28.1	28.1
	4.19	Overall length	l1 (in)	172.9	172.9
	4.20	Length to face of forks	l2 (in)	124.9	124.9
	4.21	Overall width	b1/b2 (in)	57.0 / -	57.0 / -
	4.22	Fork dimensions	s / e / l (in)	2.0 x 5.0 x 48	2.0 x 5.0 x 48
	4.23	Fork carriage type		3A	3A
	4.24	Fork carriage width	b3 (in)	53.2	53.2
	4.31	Ground clearance, loaded, below mast	m1 (in)	8.1	8.1
	4.32	Ground clearance, center of wheelbase	m2 (in)	9.6	9.6
4.34	Aisle width for pallets 40" x 48"	Ast (in)	189 ²⁾	189 ²⁾	
4.35	Turning radius	Wa (in)	112	112	
4.36	Internal turning radius	b13 (in)	33.2	33.2	
Performance	5.1	Travel speed, loaded/unloaded	mph	13.7 / 13.7	13.7 / 13.7
	5.2	Lift speed, loaded/unloaded	fpm	90 / 104	90 / 104
	5.3	Lowering speed, loaded/unloaded	fpm	108 / 108	108 / 108
	5.5	Drawbar pull, loaded/unloaded	lbf	1,910 / 1,910	1,910 / 1,910
	5.6	Max. drawbar pull, loaded/unloaded	lbf	4,945 / 4,945	4,945 / 4,945
	5.7	Gradeability, loaded/unloaded	%	15 / 27	14 / 25
	5.8	Max. gradeability, loaded/unloaded	%	19 / 30	18 / 29
	5.9	Acceleration time, loaded/unloaded	s	5.6 / 4.7	5.7 / 4.7
	5.10	Service brake		hydr./mech.	hydr./mech.
	Drive	6.1	Drive motor rating S2 60 min	kW	2 x 15
6.2		Lift motor rating at S3 15%	kW	28	28
6.3		Battery type		Linde Li-ION	Linde Li-ION
6.4		Battery specification; Size M	V / kWh	90 / 65.9	90 / 65.9
6.5		Battery weight (\pm 5%)	lb	3,214	3,214
6.7		CO2 equivalent according to DIN EN 16796	lb/hr	11.7	11.9
Others		10.1	Operating pressure for attachments	psi	2,466
	10.2	Oil volume for attachments	gpm	14.5	14.5
	10.7	Sound pressure level LpAZ (at the driver's seat)	dB(A)	67	67

1) Figures with battery

2) Including 8" operating aisle clearance.

X35 – X50 TECHNICAL DATA

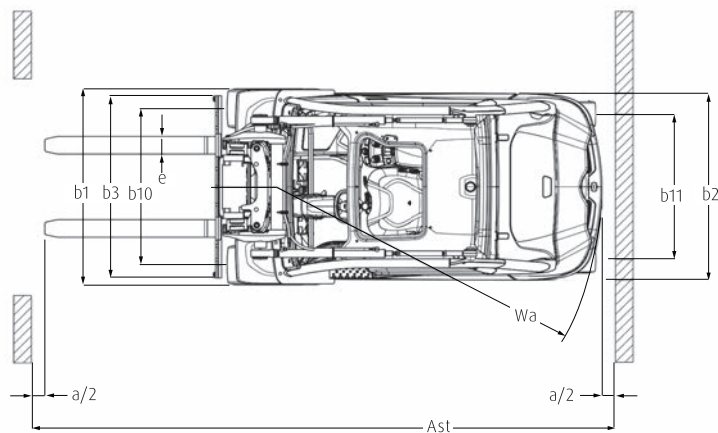
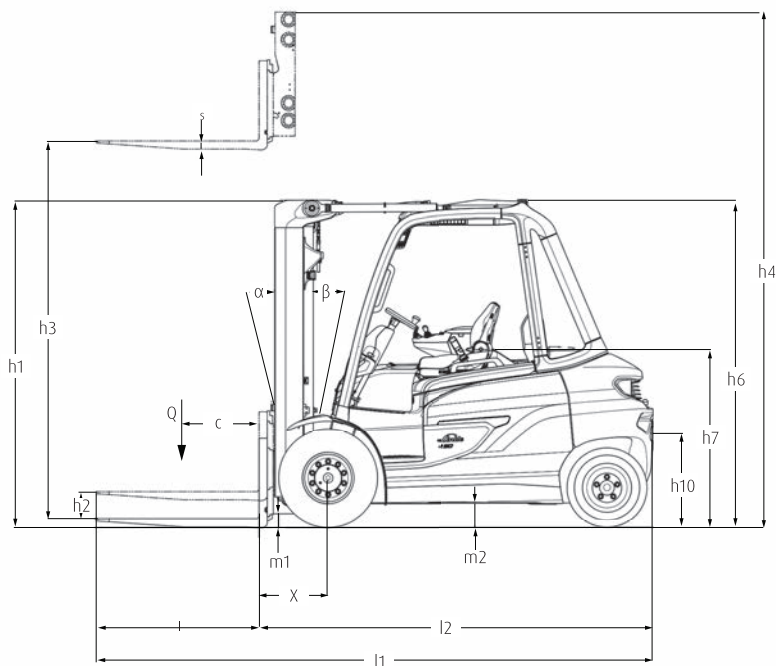

*Refer to Technical Data Chart

MAST TABLES

X35/600

Capacity (lb) at 600mm / 24" load center

Type	h1 (in)	h3 (in)	h2 (in)	Tilt	Std. Carriage	Integrated Sideshifter	Hang-on Side-shifter	Integrated Sideshifting fork positioner
Standard	94.7	126.0	0.0	5F / 8B	7,700	7,700	7,525	7,375
	98.7	133.9	0.0	5F / 8B	7,700	7,700	7,525	7,375
	104.6	145.7	0.0	5F / 8B	7,700	7,700	7,525	7,375
	108.5	153.5	0.0	5F / 8B	7,700	7,700	7,525	7,375
	112.5	161.4	0.0	5F / 8B	7,700	7,700	7,525	7,375
Duplex	122.3	181.1	0.0	5F / 8B	7,700	7,700	7,525	7,375
	95.7	127.2	58.1	5F / 8B	7,700	7,700	7,525	7,375
	99.6	135.0	62.0	5F / 8B	7,700	7,700	7,525	7,375
	105.5	146.9	67.9	5F / 8B	7,700	7,700	7,525	7,375
Triplex	113.4	162.6	75.8	5F / 8B	7,700	7,700	7,525	7,375
	95.7	187.6	58.1	5F / 8B	7,700	7,700	7,525	7,375
	97.6	193.5	60.0	5F / 8B	7,700	7,700	7,525	7,375
	99.6	199.4	62.0	5F / 8B	7,700	7,700	7,525	7,375
	103.5	211.2	65.9	5F / 8B	7,700	7,700	7,525	7,375

X35 – X50 MAST TABLES

X40/600

Capacity (lb) at 600mm / 24" load center

Type	h1 (in)	h3 (in)	h2 (in)	Tilt	Std. Carriage	Integrated Sideshifter	Hang-on Side-shifter	Integrated Sideshifting fork positioner
Standard	94.7	126.0	0.0	5F / 8B	8,800	8,800	8,750	8,550
	98.7	133.9	0.0	5F / 8B	8,800	8,800	8,750	8,550
	104.6	145.7	0.0	5F / 8B	8,800	8,800	8,750	8,550
	108.5	153.5	0.0	5F / 8B	8,800	8,800	8,750	8,550
	112.5	161.4	0.0	5F / 8B	8,800	8,800	8,750	8,550
	122.3	181.1	0.0	5F / 8B	8,800	8,800	8,750	8,550
Duplex	95.7	127.2	58.1	5F / 8B	8,800	8,800	8,750	8,550
	99.6	135.0	62.0	5F / 8B	8,800	8,800	8,750	8,550
	105.5	146.9	67.9	5F / 8B	8,800	8,800	8,750	8,550
	113.4	162.6	75.8	5F / 8B	8,800	8,800	8,750	8,550
Triplex	95.7	187.6	58.1	5F / 8B	8,800	8,800	8,750	8,550
	97.6	193.5	60.0	5F / 8B	8,800	8,800	8,750	8,550
	99.6	199.4	62.0	5F / 8B	8,800	8,800	8,750	8,550
	103.5	211.2	65.9	5F / 8B	8,800	8,800	8,700	8,500

X45/600

Capacity (lb) at 600mm / 24" load center

Type	h1 (in)	h3 (in)	h2 (in)	Tilt	Std. Carriage	Integrated Sideshifter	Hang-on Side-shifter	Integrated Sideshifting fork positioner
Standard	96.7	126.0	0.0	5F / 8B	9,900	9,900	9,775	9,625
	100.6	133.9	0.0	5F / 8B	9,900	9,900	9,775	9,625
	106.5	145.7	0.0	5F / 8B	9,900	9,900	9,775	9,625
	110.5	153.5	0.0	5F / 8B	9,900	9,900	9,775	9,625
	114.4	161.4	0.0	5F / 8B	9,900	9,900	9,775	9,625
	124.3	181.1	0.0	5F / 8B	9,900	9,900	9,775	9,625
Duplex	97.6	127.2	60.0	5F / 8B	9,900	9,900	9,775	9,625
	101.6	135.0	64.0	5F / 8B	9,900	9,900	9,775	9,625
	107.5	146.9	69.9	5F / 8B	9,900	9,900	9,775	9,625
	115.4	162.6	77.8	5F / 8B	9,900	9,900	9,775	9,625
Triplex	97.6	187.6	60.0	5F / 8B	9,900	9,900	9,775	9,625
	99.6	193.5	62.0	5F / 8B	9,900	9,900	9,775	9,625
	101.6	199.4	64.0	5F / 8B	9,900	9,900	9,775	9,625
	105.5	211.2	67.9	5F / 8B	9,900	9,900	9,775	9,550

X35 – X50 MAST TABLES

X50/500

Capacity (lb) at 600mm / 24" load center

Type	h1 (in)	h3 (in)	h2 (in)	Tilt	Std. Carriage	Integrated Sideshifter	Hang-on Side-shifter	Integrated Sideshifting fork positioner
Standard	100.6	126.0	0.0	5F / 8B	10,000	10,000	9,850	9,625
	110.5	145.7	0.0	5F / 8B	10,000	10,000	9,850	9,625
	118.4	161.4	0.0	5F / 8B	10,000	10,000	9,850	9,625
	132.1	198.0	0.0	5F / 8B	10,000	10,000	9,850	9,625
Duplex	97.6	119.3	56.1	5F / 8B	10,000	10,000	9,850	9,625
	101.6	127.2	60.0	5F / 8B	10,000	10,000	9,850	9,625
	107.5	139.0	65.9	5F / 8B	10,000	10,000	9,850	9,625
	115.4	154.7	73.8	5F / 8B	10,000	10,000	9,850	9,625
Triplex	97.6	175.8	56.1	5F / 8B	10,000	10,000	9,850	9,625
	99.6	181.7	58.1	5F / 8B	10,000	10,000	9,850	9,625
	101.6	187.6	60.0	5F / 8B	10,000	10,000	9,850	9,625
	105.5	199.4	64.0	5F / 6B	10,000	10,000	9,850	9,625
	107.5	205.3	65.9	5F / 6B	10,000	10,000	9,850	9,625
	113.4	219.1	71.9	5F / 6B	10,000	10,000	9,400	9,200

X50/600

Capacity (lb) at 600mm / 24" load center

Type	h1 (in)	h3 (in)	h2 (in)	Tilt	Std. Carriage	Integrated Sideshifter	Hang-on Side-shifter	Integrated Sideshifting fork positioner
Standard	100.6	126.0	0.0	5F / 8B	11,000	11,000	10,000	10,600
	110.5	145.7	0.0	5F / 8B	11,000	11,000	10,000	10,600
	118.4	161.4	0.0	5F / 8B	11,000	11,000	10,000	10,600
	132.1	198.0	0.0	5F / 8B	11,000	11,000	10,000	10,600
Duplex	97.6	119.3	56.1	5F / 8B	11,000	11,000	10,000	10,600
	101.6	127.2	60.0	5F / 8B	11,000	11,000	10,000	10,600
	107.5	139.0	65.9	5F / 8B	11,000	11,000	10,000	10,600
	115.4	154.7	73.8	5F / 8B	11,000	11,000	10,000	10,600
Triplex	97.6	175.8	56.1	5F / 8B	11,000	11,000	10,000	10,600
	99.6	181.7	58.1	5F / 8B	11,000	11,000	10,000	10,600
	101.6	187.6	60.0	5F / 8B	11,000	11,000	10,000	10,600
	105.5	199.4	64.0	5F / 8B	11,000	11,000	10,000	10,600
	107.5	205.3	65.9	5F / 5B	11,000	11,000	10,000	10,600
	113.4	219.1	71.9	5F / 5B	10,375	10,225	10,000	9,800

CHARACTERISTICS



Panoramic view



Operator's workstation

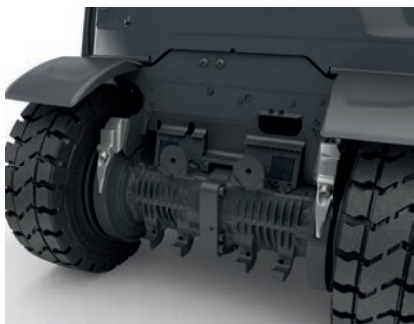

Drive Concept



Service access

Productivity

- Narrow mast profiles, A-pillar and roof designed for provide optimum visibility of load and surroundings
- Low centre of gravity and automatic speed reduction in corners increases driver confidence
- Automatic parking brake ensures safe parking on grades
- Numerous optional operator assistance systems, lighting and warning systems

Ergonomics

- Intuitive, and ergonomic operating concept minimises physical strain on the operator
- Operator's workstation is isolated from the mast and axles by means of rubber bearings, which protects the operator in intensive applications and over uneven ground
- Spacious operator's cab and a range of ergonomic seats for fatigue-free working
- Comprehensive 3.5 inch display optimally positioned for access to all relevant truck information at a glance

Handling

- Long wheel base and large diameter tires give stability when handling loads outdoors and on uneven surfaces
- Twin motor front-wheel drive with high performance synchronous reluctance motors (SRM+) for maximum power and manoeuvrability
- Precise and intuitive control of all driving and lifting movements via twin or single pedal control and Linde Load Control
- Torsion-resistant mast construction and high mounted tilt cylinders result in high residual load capacity and secure load handling

Service

- High availability due to a robust, modular design as well as numerous wear and maintenance free components
- Low maintenance costs due to long service intervals and easily accessible components
- Remote diagnostics and wireless software updates aid preventive maintenance and reduce the workload for service technicians
- Modular components allow fast diagnosis and quick replacement reducing downtime



MONTREAL (Head office)
19151 A, Cruickshank Avenue
Baie-D'Urfé (Québec) H9X 3N9
Phone: 418 694-4223
Toll free: 1 866 421-4223
info@elevex.ca
elevex.ca

QUEBEC
1279, Paul-Émile Giroux St. Suite
200 Québec (Québec) G1C 0K9

SAGUENAY
2305, Alexis-Le-Trotteur
St. Jonquière (Québec) G7X 9H8



Member of KION Group