



# NARROW AISLE, SINGLE, DOUBLE REACH TRUCK R15SX / R17SX / R22SX

**3,000 - 4,500 lbs. Capacity**

Series 5195

- With over 70 years of designing and manufacturing the most reliable forklift trucks in the industry, Linde understands narrow aisle applications
- AC components allow controlled acceleration, smooth maneuvering, and responsive braking. Cushioned hydraulic functions and mast staging are also included with power lowering
- Comfort and visibility in all load handling functions are enhanced with a clear view overhead guard. The operator does not have to lean outside the frame of the truck to see loads at extended heights
- The service compartment allows full access to the main components with a service door that fully opens. On-board diagnostics allow Linde technicians to quickly and effectively check and address truck systems

# STANDARD & OPTIONAL EQUIPMENT

## STANDARD

- Side stance position
- 24V system (includes 350 Amp battery connector)
- Single reach mast (24" extend) with 33" wide class II hook type carriage
- Double reach mast (42" extend) with 33" wide class II hook type carriage (R15SX)
- Tilting carriage: 3° forward / 4° backward
- Rear post operator protection
- Operator's overhead guard
- Comfort floormat
- Cushioning soft hydraulics
- Reduced travel speed with carriage extended
- Control handle with simultaneous hydraulic functions
- Forks 1.5" x 4" x 42" class II hook type carriage (R17SX, R15SX)
- Forks 1.75" x 4" x 42" class II hook type carriage (R22SX)
- 5" x 4" poly articulating tandem load wheels (R17SX, R15SX)
- 6" x 4" poly articulating tandem load wheels (R22SX)
- 13.5" x 5.3" polyurethane drive tire construction
- Integral side-shift standard
- 42.0" L x 14.6" W x 38.75" H battery compartment
- AC traction, lift/lower and steering
- Standard connection
- Low step height
- Cup holder
- UL classification type "E"
- Key switch start
- Steering returns to 0 upon start
- Battery rollers
- Power disconnect
- Padded operator compartment
- Static strap
- Electronic horn
- 42" load backrest
- Programmable traction speed and acceleration
- Electric power steering
- Dual polyurethane caster wheels
- LED display
- Back lighting
- Battery discharge indicator with lift interrupt
  - Hour meter, truck, traction and hoist pump
  - LED status indicators and symbols
  - Steer wheel angle graphic indication
  - Truck speed in mph or km/h

## OPTIONAL

- 36V electrical system
- UL classification "EE"
- Reverse steering
- Power lower unloaded
- Regenerative lower loaded (standard on the R15SX)
- Laser position indicator
- Camera system for extended lift heights
- Fork height indicator
- Safety glass mast guard
- See-through armored glass OHG
- Pin code / toggle switch
- Environmental construction
  - Cooler freezer conditioning: -26°F to 110°F
  - Corrosion
  - Food grade: 32°F to 110°F
- Various mast options available
- Various fork length options available
- Keyless start
- Poly siped tires
- Poly x groove tires
- 48" load backrest extension
- Back-up / motion alarms
- Amber strobe light
- Linde BlueSpot™ front
- Linde BlueSpot™ back
- Operator desktop light
- Dual headlights
- Rear work light
  - Operator fan
  - RF utility pole
  - Parts manual
  - Service manual

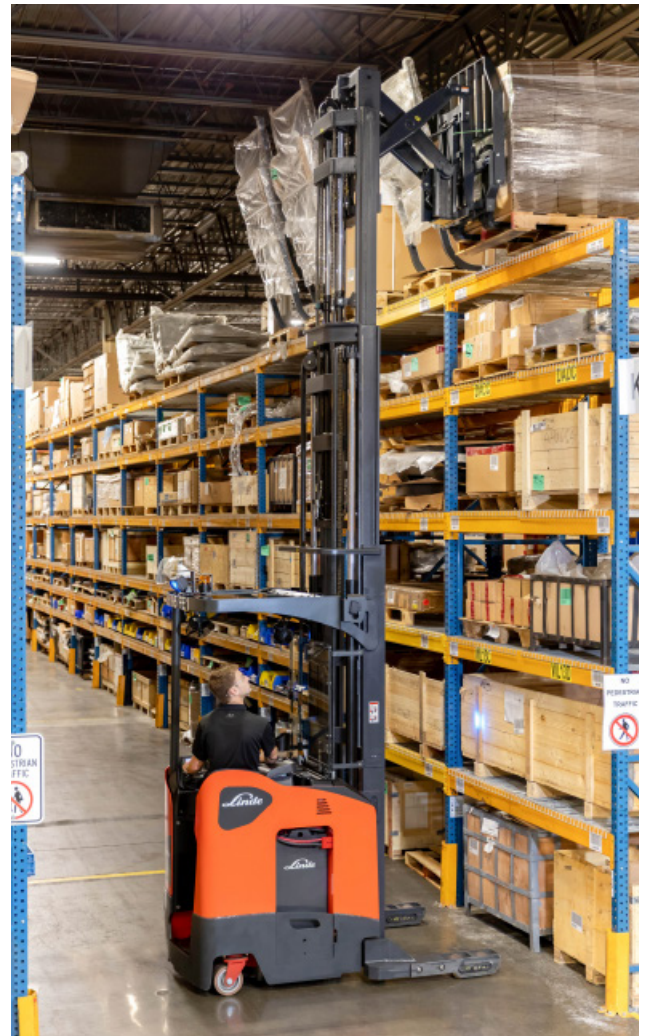

# REACH TRUCK TECHNICAL DATA

February 2020

		LINDE											
Characteristics	1.1	Manufacturer											
	1.2	Model designation		R17SX-24V		R17SX-36V		R22SX		R15SX			
	1.3	Power unit		Electric		Electric		Electric		Electric			
	1.4	Operation		Stand-on		Stand-on		Stand-on		Stand-on			
	1.5	Load capacity	Q	lbs	kg	3500	1588	3500	1588	4500	2041	3000	1361
	1.6	Load center	c	in	mm	24	600	24	600	24	600	24	600
	1.8	Axle center to fork face	x	in	mm	11.8	299	11.8	299	10.8	274	5.4	136
	1.9	Wheelbase	y	in	mm	58.9	1497	60.9	1548	60.9	1548	60.9	1548
Weights	2.1	Service weight		lbs	kg	7517.8	3410	8245.3	3740	8774.4	3980	8950.8	4060
	2.3	Axle load without load, front (drive)/rear (load)		lbs	kg	934.4	2060	5026.5	2280	5180.9	2350	5180.9	2350
	2.4	Axle load, fork outreached with load, front (drive)/rear (load)		lbs	kg	412.8	910	2579.4	1170	2314.9	1050	1399.9	635
	2.5	Axle load, fork retracted with load, front (drive)/rear (load)		lbs	kg	753	1660	4188.8	1900	3825	1735	4100.6	1860
Wheels	3.1	Tires, front/rear <sup>1</sup> C=cushion rubber, P=polyurethane				P/P		P/P		P/P		P/P	
	3.2	Tire size, front (drive) wheel		in	mm	13.5x5.1	343x135	13.5x5.1	343x135	13.5x5.1	343x135	13.5x5.1	343x135
	3.3	Tire size, rear (load) wheel		in	mm	5x4	127x102	5x4	127x102	5x4	152x102	5x4	152x102
	3.5	Wheels, number front (drive)/rear (load) (X=driven)				1x+1/4		1x+1/4		1x+1/4		1x+1/4	
	3.6	Track width, front (drive)	b <sub>10</sub>	in	mm	30.5	774	30.5	774	30.5	774	30.5	774
	3.7	Track width, rear (load)	b <sub>11</sub>	in	mm	40.1	1018	40.1	1119	40.1	1170	40.1	1170
Dimensions	4.1	Mast/fork carriage tilt, forward/backward			°	3/4		3/4		3/4		3/4	
	4.2	Height of mast, lowered	h <sub>1</sub>	in	mm	107	2718	107	2718	107	2718	107	2718
	4.3	Free lift	h <sub>2</sub>	in	mm	74.6	1895	74.6	1895	78.8	2002	78.8	2002
	4.4	Lift	h <sub>3</sub>	in	mm	240	6096	240	6096	240	6096	240	6096
	4.5	Height of mast, extended	h <sub>4</sub>	in	mm	281.7	7155	281.7	7155	281.7	7155	281.7	7155
	4.7	Height of overhead guard (cabin)	h <sub>6</sub>	in	mm	100.2	2545	100.2	2545	93.8	2383	93.8	2383
	4.10	Height of reach legs	h <sub>8</sub>	in	mm	5.1	130	5.1	130	5.1	160	5.1	160
	4.19	Overall length	l <sub>1</sub>	in	mm	101	2566	103	2617	105.3	2675	108	2744
	4.20	Length to fork face	l <sub>2</sub>	in	mm	58.7	1491	60.7	1542	70	1549	67.1	1704
	4.21	Overall length	b <sub>1</sub> /b <sub>2</sub>	in	mm	43.2/45	1098/1142	42.9/48.9	1089/1243	42.9/48.9	1089/1294	42.9/48.9	1089/1294
	4.22	Fork dimensions	s <sub>e</sub> /l	in	mm	1.5*4*42	38*102*1067	1.5*4*42	38*102*1067	1.8*4*42	45*102*1067	1.5*4*42	38*102*1067
	4.23	Fork carriage to DIN 15 173, Class/Form A/B				2A		2A		2A		2A	
	4.24	Width of fork carriage	b <sub>3</sub>	in	mm	33	838	33	838	33	838	33	838
	4.25	Fork spread, minimum/maximum	b <sub>5</sub>	in	mm	25.4/9.7	644/246	25.4/9.7	644/246	25.4/9.7	644/246	25.4/9.7	644/246
	4.26	Width between reach legs	b <sub>4</sub>	in	mm	34.1	865	38	966	40	1017	40	1017
	4.28	Reach travel	l <sub>4</sub>	in	mm	23.7	603	23.7	603	23.7	603	41.2	1047
	4.31	Ground clearance, mast	m <sub>1</sub>	in	mm	1.9	47	1.9	47	1.9	47	1.9	47
	4.32	Ground clearance, center of wheelbase	m <sub>2</sub>	in	mm	1.8	45	1.8	45	1.8	45	1.8	45
	4.33	Aisle width, with pallet 39.37" x 47.24" across forks	A <sub>st</sub>	in	mm	114.7	2913	116.7	2964	116.7	2965	121.7	3092
Aisle width, with pallet 39.37" x 47.24" across forks		A <sub>st</sub>	in	mm	106.8	2713	108.8	2764	108.8	2765	113.9	2892	
Aisle width, with pallet 31.50" x 47.24" across forks		A <sub>st</sub>	in	mm	117.2	2976	119.2	3027	119.4	3032	125.1	3177	
Aisle width, with pallet 31.50" x 47.24" across forks		A <sub>st</sub>	in	mm	109.3	2776	111.3	2827	111.5	2832	117.2	2977	
Aisle width, with pallet 43.30" x 43.30" across forks		A <sub>st</sub>	in	mm	116.6	2962	118.6	3012	118.7	3015	124	3150	
Aisle width, with pallet 43.30" x 43.30" across forks		A <sub>st</sub>	in	mm	108.7	2762	110.7	2812	110.8	2815	116.1	2950	
4.35	Turning radius	W <sub>a</sub>	in	mm	70.5	1790	72.5	1841	71.8	1823	72.4	1840	
4.37	Length of chassis	l <sub>7</sub>	in	mm	78.1	1983	80.1	2034	80.4	2041	81	2058	
Performance	5.1	Traveling speed, with/without load		mph	km/h	6.5/8.1	10.5/13	6.5/8.1	10.5/13	6.5/8.1	10.5/13	6.5/8.1	10.5/13
	5.2	Lifting speed, with/without load		fpm	m/s	53.1/88.6	0.27/0.45	78.7/128	0.40/0.65	68.9/128	0.35/0.65	68.9/128	0.35/0.65
	5.3	Lowering speed, with/without load		fpm	m/s	104.3/84.6	0.53/0.43	104.3/104.3	0.53/0.53	104.3/104.3	0.53/0.53	104.3/104.3	0.53/0.53
	5.4	Reach speed, with/without load		fpm	m/s	33.5/33.5	0.17/0.17	33.5/33.5	0.17/0.17	33.5/33.5	0.17/0.17	33.5/33.5	0.17/0.17
	5.8	Max climbing ability, with/without load, 5 min. rating			%	10/10		10/10		10/10		10/10	
5.10	Service brake				Electrical		Electrical		Electrical		Electrical		
Drive	6.1	Drive motor, 60 minute rating				4.9		6.6		6.6		6.6	
	6.2	Lift motor, 15% rating				9.3		15.4		15.4		15.4	
	6.3	Battery according to IEC				60254-2		60254-2		60254-2		60254-2	
	6.4	Battery voltage/rated capacity (5H)			V/Ah	24		36		36		36	
	6.5	Battery weight (±5%)		lbs	kg	1684.3	764	2151.7	976	2151.7	976	2151.7	976

NOTICE: Products are subject to change without notice. Our products are continuously being improved, all conditions, terms, and specifications are subject to change at any time.

# R15SX TECHNICAL DRAWING

February 2020

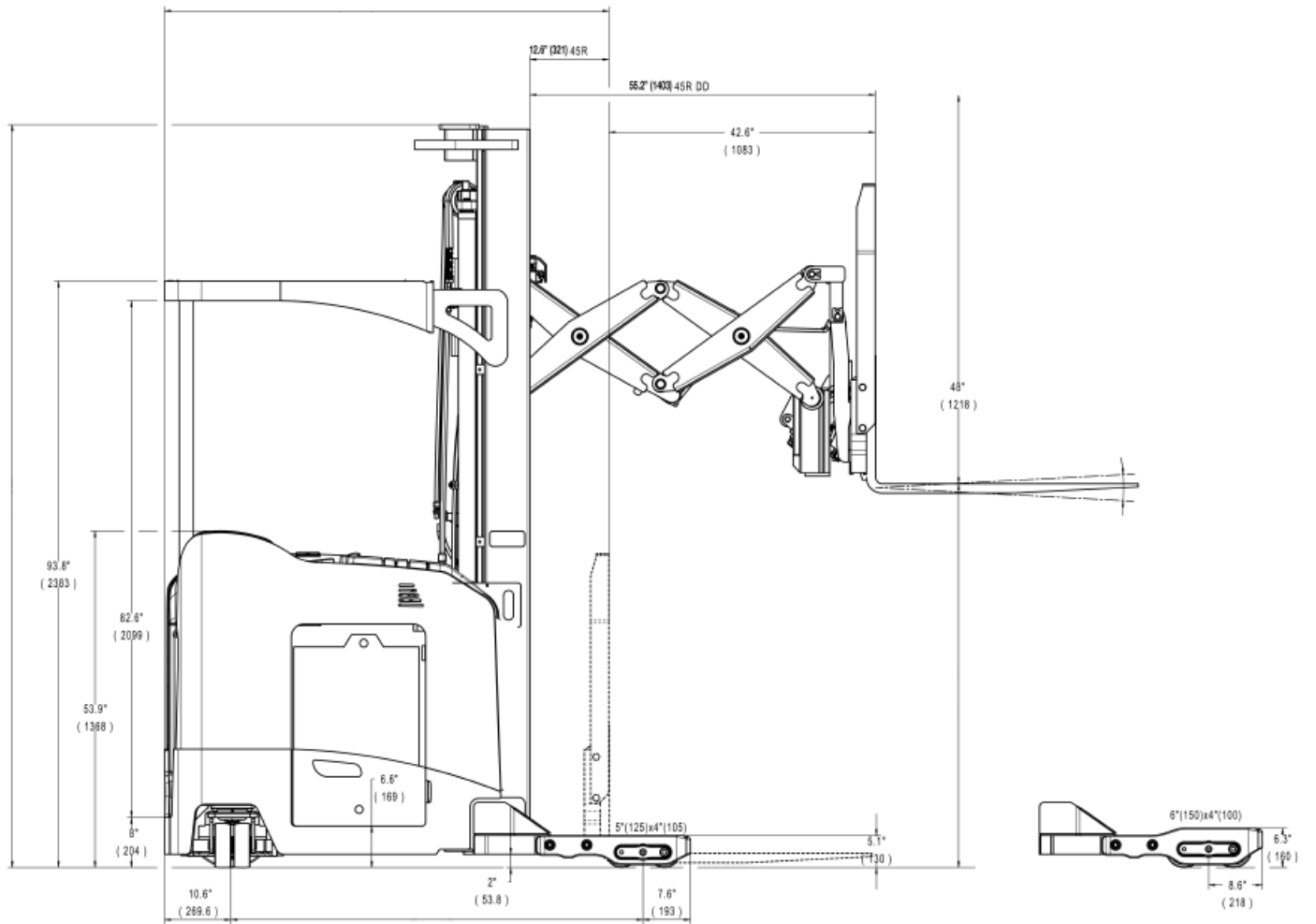
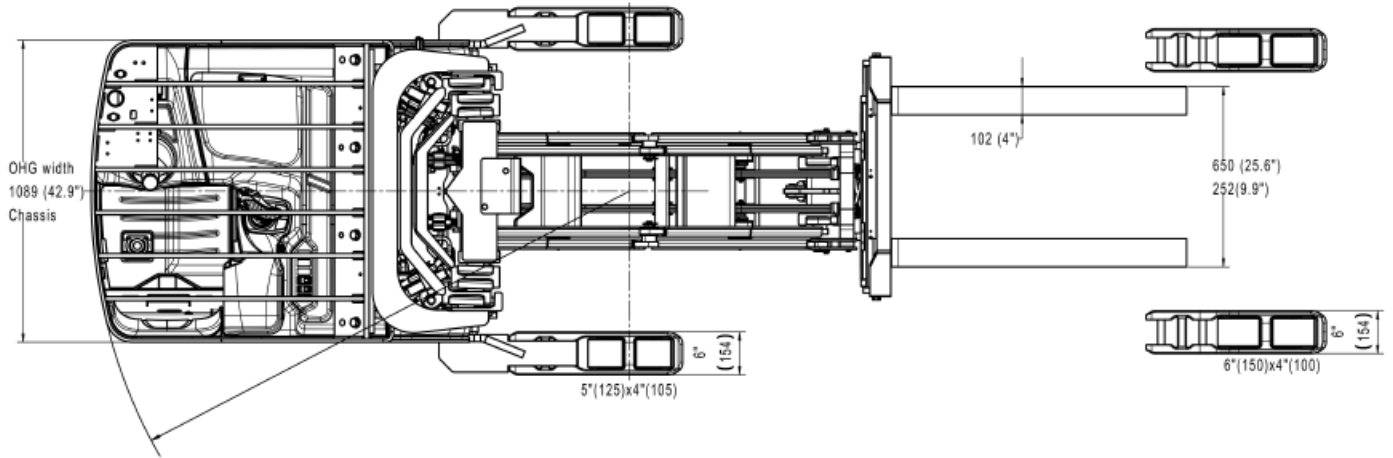

# R17-22SX TECHNICAL DRAWING

February 2020

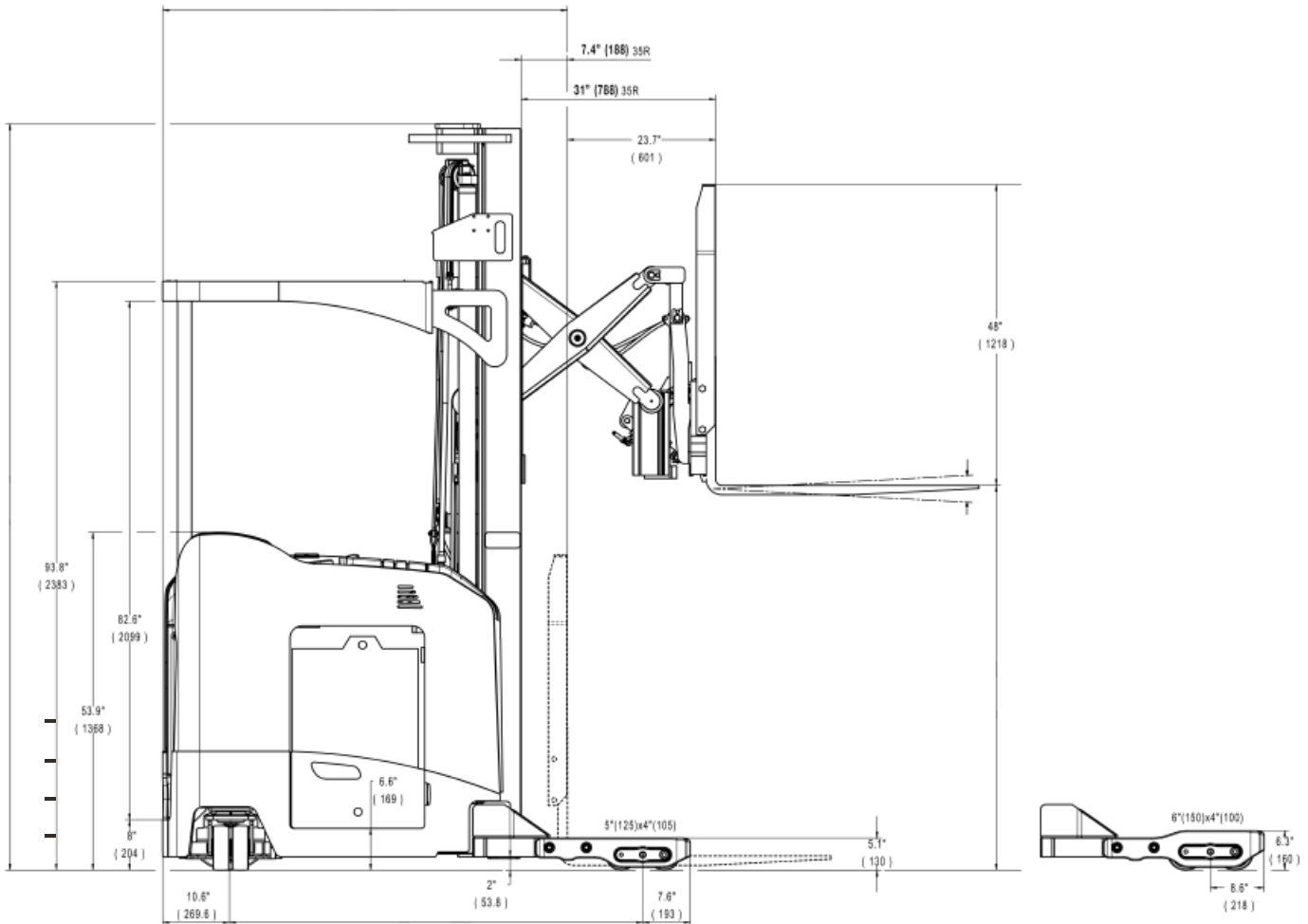
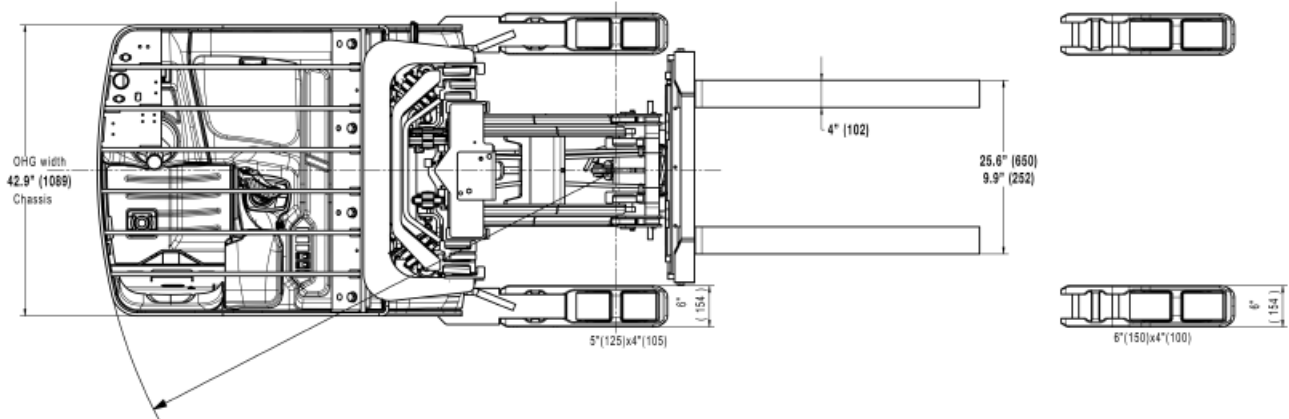

# MAST DIMENSIONS AND BATTERY SPECIFICATIONS

MAST DIMENSIONS			
Max Fork Height	Overall Lowered Height	Overall Height (Mast Extended) Highest Point w/42" Load Backrest	Free-lift (TOF)
in (mm)	in (mm)	in (mm)	in (mm)
210 (5334)	95 (2413)	252 (6401)	62.6 (1590)
240 (6096)	107 (2718)	282 (7193)	74.6 (1895)
258 (6553)	113 (2870)	300 (7620)	80.6 (2047)
270 (6858)	119 (3023)	312 (7625)	86.6 (2199)
300 (7620)	131 (3327)	342 (8681)	98.6 (2504)
318 (8077)	139 (3531)	360 (8144)	106.6 (2707)
330 (9296)	149 (3785)	372 (9442)	116.6 (2961)
366 (9296)	161 (4089)	408 (10363)	128.6 (3266)
385 (9779)	167 (4242)	427 (10846)	134.6 (3419)
400 (10160)	173 (4394)	442 (11222)	140.6 (3571)
425 (10795)	185 (4699)	467 (11862)	152.6 (3876)

## RIGHT ANGLE AISLE STACKING

R17SX - 24V					
Truck with 14.5" Battery Compartment and 34" ID					
3 Stage - 4" Between Loads					
Pallet Length (in)	Pallet Width (in)				
		36	40	44	48
	36	93	94	95	97
	40	96	97	98	100
	44	99	100	101	103
48	103	104	105	106	

Add 2" for 16.5" battery compartment  
Add 2" for 18.5" battery compartment

R22SX					
Truck with 16.5" Battery Compartment and 40" ID					
3 Stage - 4" Between Loads					
Pallet Length (in)	Pallet Width (in)				
		36	40	44	48
	36	95	96	97	99
	40	98	99	100	102
	44	102	103	104	105
48	105	106	107	108	

Add 2" for 18.5" battery compartment  
Add 2" for 20.5" battery compartment

R15SX					
Truck with 16.5" Battery Compartment and 42" ID					
3 Stage - 4" Between Loads					
Pallet Length (in)	Pallet Width (in)				
		36	40	44	48
	36	100	101	102	103
	40	103	104	105	107
	44	107	108	109	110
48	111	112	112	113	

Add 2" for 18.5" battery compartment  
Add 2" for 20.5" battery compartment  
For right angle stack, add min. 6" clearance for ease of operation

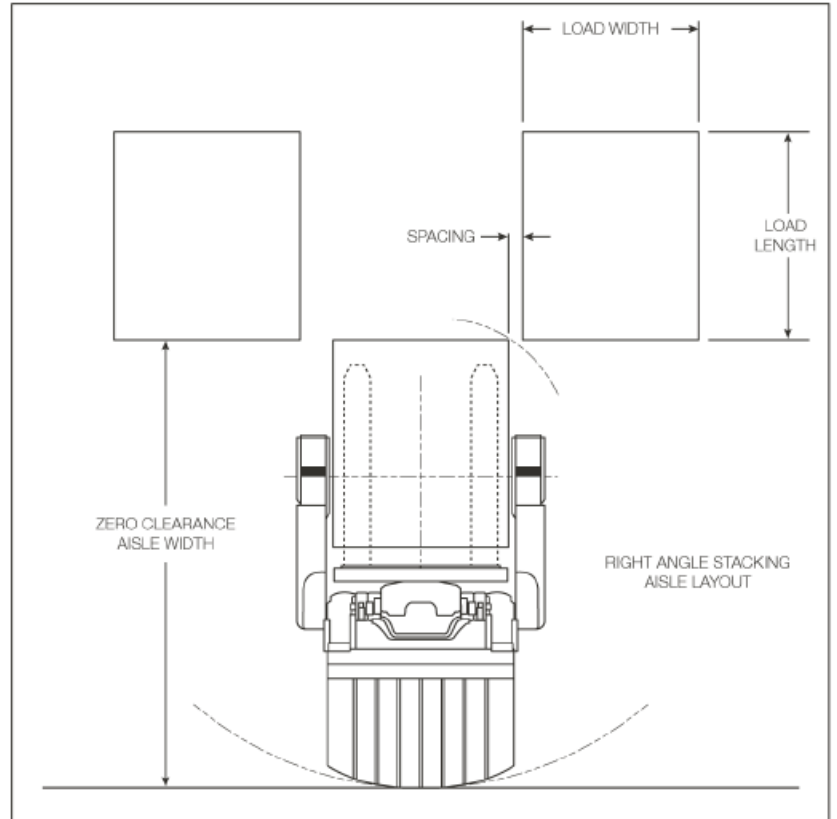

Battery and Compartment Specifications											
Battery Specifications											
Battery Compartment Size	Battery Voltage	Maximum 6-hr Rate		Battery Dimensions						Min. Battery Weight	Max. Battery Weight
				"X" Max.		"Y" Max.		"Z" Max.			
		ah	kwh	in	mm	in	mm	in	mm	lbs (kg)	lbs (kg)
14.5"	24	1240	29.0	38.8	(985)	14.25	(362)	30.5	(775)	1684.3 (764)	2184 (991)
16.5"	36	775	27.2	38.8	(985)	16.25	(413)	30.5	(775)	2151 (976)	2651 (1202)
18.5"	36	1395	32.6	38.8	(985)	18.25	(467)	30.5	(775)	2151 (976)	2651 (1202)
21.5"	36	930	32.6	38.8	(985)	21.25	(540)	30.5	(775)	2151 (976)	2651 (1202)

# FEATURES



Cushioned Hydraulics



Power Lowering



Visibility



Operator Comfort

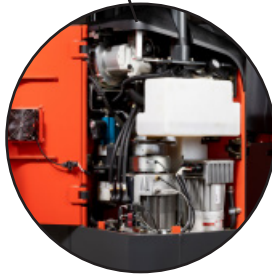

Open Access to Components

## Linde Series 5195 Five Features

**Operator Comfort:** The operator compartment's adjustable steer tiller and control handle, coupled with the widest compartment in the industry, keeps an operator comfortable and productive all day long. **Open Access to Components:** With a service door that opens well beyond 90 degrees, a technician has full and easy access to all necessary componentry, allowing for the truck to get back in service faster.

**Power Lowering:** Linde's powered lowering drastically increases lowering speeds, reducing overall cycle times and pumping energy back in to the battery. Extended run times and reduced cycle times make the Series 5195 an efficient material handling solution.

**Cushioned Hydraulics:** Linde's cushioned hydraulic system allows for delicate handling of any load, increasing operator efficiency while helping to guard from product damage.

**Visibility:** Linde's glass overhead guard provides an operator with zero obstructions while looking through the overhead guard. This increases fork accuracy, and in turn, decreases cycle time and product damage.



**MONTREAL (Head office)**  
19151 A, Cruickshank Avenue  
Baie-D'Urfé (Québec) H9X 3N9  
Phone: 418 694-4223  
Toll free: 1 866 421-4223  
[info@elevex.ca](mailto:info@elevex.ca)  
[elevex.ca](http://elevex.ca)

**QUEBEC**  
1279, Paul-Émile Giroux St. Suite  
200 Québec (Québec) G1C 0K9

**SAGUENAY**  
2305, Alexis-Le-Trotteur  
St. Jonquière (Québec) G7X 9H8



ANSI: Standard truck meets all applicable mandatory requirements of ANSI/ITSDF B56.1 standards for powered industrial trucks.  
NOTE: Performance data may vary due to motor and system efficiency tolerances. The performance depicted represents nominal values obtained under typical operating conditions. Metric dimensions are in millimeters unless otherwise specified. All metric dimensions are rounded due to rounding data. The descriptions and specifications included on this data sheet were in effect at the time of printing. KION North America Corporation reserves the right to make improvements and changes in specification or design without notice and without incurring obligation. Please check with your authorized Linde dealer for information on possible updates or revisions.