



Linde Material Handling

Linde



Li-ION Pallet Truck

MT15B

Capacity 3,300 lb. | Series 8932

- Small size and reduced weight for improved maneuverability
- Lift 3,300 lb. at 24 in. load center to the max height of 7.5 in. with ease
- Equipped with a 20Ah Li-ion battery, the on-board charger enables quick charging, maximizing operational flexibility.
- All operator controls available without lifting one's hand from the ergonomic grips

STANDARD & OPTIONAL EQUIPMENT

		MT15B
Fork dimension	27 in W x 45 in L (685 mm x 1150 mm)	●
Drive cover off the ground	2.1 in (55 mm)	●
Load wheel type	Single Polyurethane	●
Stability Cater wheels X2		●
Polyurethane Load & Drive wheels		●
Battery capacity	24V/20AH - Qty.1 With On-board Charger	●
	24V/20AH - Qty.2 With Optional off board Charger	○
Charger	24V-10A external charger	○
Battery indicator		●
Square-tube tiller head		●

● Standard equipment ○ Optional equipment

MT15B TECHNICAL DATA

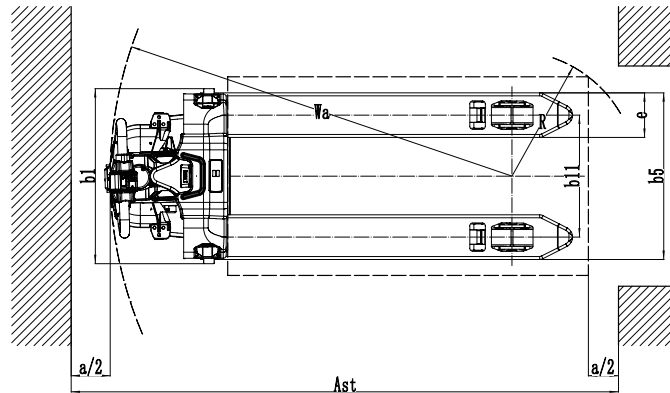
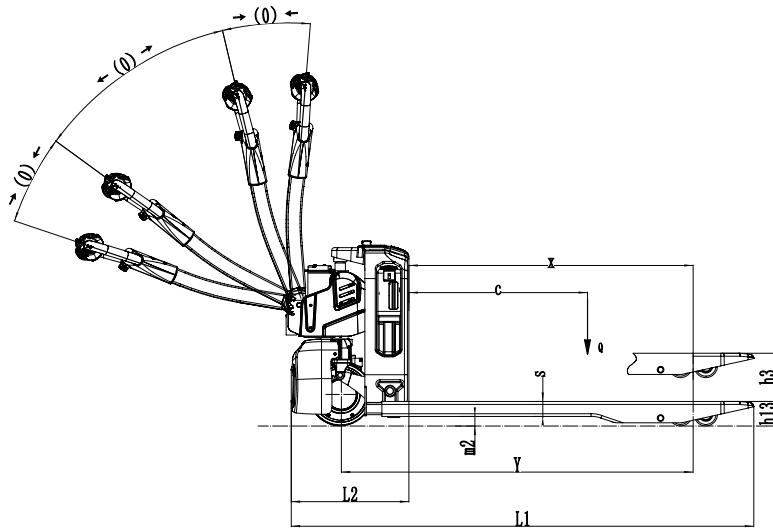

MT15B TECHNICAL DATA

Characteristics	1.1	Manufacturer				LINDE	
	1.2	Model designation				MT15B	
	1.2a	Series				8932	
	1.3	Drive system				Li-ION battery	
	1.5	Rated capacity/rated load	Q	lb	kg	3,300	1497
	1.6	Load center distance	c	in	mm	24	600
	1.8	Load distance, center of drive axle to fork	x	in	mm	37.4	950
	1.9	Wheelbase	y	in	mm	46.4	1180
	Weights	2.1	Service weight		lb	kg	264.5
2.3		Axle loading, unloaded front/rear		lb	kg	198/66	90/30
Wheels/Tires	3.1	Tire type				Polyurethane	
	3.2	Tire size, front		in	mm	8.26x2.7	210/70
	3.3	Tire size, rear		in	mm	3.14x3.36	80/60
	3.4	Additional wheels (castor wheels)		in	mm	2.91x1.18	74/30
	3.5	Wheels, number front/rear (× = driven wheels)				1x2	
	3.6	Tread width, front	b10	in	mm	---	
	3.7	Tread width, rear	b11	in	mm	16.14 (13.89)	410 (535)
Dimensions	4.4	Lift	h3	in	mm	4.13	105
	4.9	Height of tiller handle in drive position min./max.	h10	in	mm	29.5/46.8	750/1190
	4.15	Lowered height	h13	in	mm	3.2	82
	4.19	Overall length	l1	in	mm	61	1550
	4.20	Length to face of forks	l2	in	mm	15.7	400
	4.21	Overall width	b1/b2	in	mm	23.2 (27.3)	590 (695)
	4.22	Fork dimensions	s / e / l	in	mm	1.9/5.9/45.2	50X150X1150
	4.25	Distance between fork-arms	b5	in	mm	22 (26.9)	560 (685)
	4.34.1	Aisle width for pallets 1000×1200 crossways	Ast	in	mm	85	2160
	4.34.2	Aisle width for pallets 800×1200 lengthways	Ast	in	mm	79.72	2025
4.35	Turning radius	Wa	in	mm	53.54	1360	
Performance	5.1	Travel speed, loaded/unloaded		mph	km/h	2.8/2.8	4.5/4.5
	5.2	Lift speed, loaded/unloaded		fpm	m/s	3.34/ 3.93	0.017/0.02
	5.3	Lowering speed, loaded/unloaded		fpm	m/s	11.41/9.05	0.058/0.046
	5.8	Max. gradeability, loaded/unloaded			%	5/16	
	5.10	Service brake				Electromagnetic	
Drive	6.1	Drive motor rating S2 60 min			kW	0.75	
	6.2	Lift motor rating at S3 15%			kW	0.5	
	6.4	Battery voltage/nominal capacity			V / Ah	24/20	
	6.5	Battery weight (± 5%)		lb	kg	11	5
	6.6	Energy consumption according to DIN EN 16796			kWh/h	0.18 ¹	
	6.7	Turnover output according to VDI 2198			t/h	88	
	6.8	Turnover efficiency according to VDI 2198			t/kWh	473.12	
	8.1	Type of drive control				BLDC	
Others	10.5	Steering design				Mechanical	
	10.7	Sound pressure level LpAZ (at the driver's seat)			dB(A)	74	
	15.1	Charger output current			A	---	

CHARACTERISTICS



Li-ion Technology

- The MT15B comes with a standard 20Ah Li-ion battery and onboard charger, which offers high availability to multishift work thanks to fast and flexible charging and zero maintenance.
- Optimized for opportunity charging when pallet truck is not in use
- Up to 3-hour battery charge, or up to 6 hours with optional secondary Li-ion battery in place of on-board charger



Ergonomics

- The low-mounted tiller arm offers excellent operator comfort and minimum steering effort.
- Travel, lift, and lower functions are located on the ergonomic control head.
- The control head is designed for easy operation with either hand and includes a belly button reversing switch, dual butterfly travel controls, horn, and battery discharge indicator.
- Creep speed functionality and small size give operator confidence in tight spaces



Cost Reductions

- Maintenance-free Lithium-Ion battery improves battery life and working efficiency
- Reduce electrical costs because of better charger efficiency



Member of KION Group



MONTREAL (Head office)

19151 A, Cruickshank Avenue
Baie-D'Urfé (Québec) H9X 3N9
Phone: 418 694-4223
Toll free: 1 866 421-4223
info@elevex.ca
elevex.ca

QUEBEC

1279, Paul-Émile Giroux St. Suite 200
Québec (Québec) G1C 0K9

SAGUENAY

2305, Alexis-Le-Trotteur
St. Jonquière (Québec) G7X 9H8

