



**MINI 4 - 6**

- Traction motor AC
- Power Steering
- Hydraulic brakes
- Big Battery 24 V 375 Ah
- Lifting height to 168.5"
- Electronic lift control
- Right Angle Stack 94.7"

**MOST DETAILS MINI 4 - 6**

HEIGHT		STANDARD INCL. SIDE-SHIFT	DUPLEX INCL. SIDE-SHIFT	TRIPLEX INCL. SIDE-SHIFT
Lift height	$h_{23}$	114	112	169
Closed mast height	$h_1$	74.8	74.8	74.8
Height mast extended *	$h_4$	159.1	157.5	213.8
Free lift	$h_2$		56.1	56.1
Overall width MINI 4-6	$b_1$	33.4	33.4	35.8

\* With Backrest

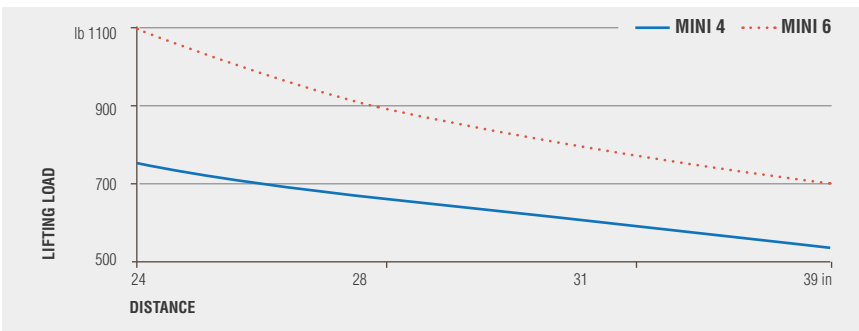

Data showed are not binding and are liable to variations.  
The constructor reserves the right of changes without notice.

★ On demand installation of the strobo light under the height of the overhead guard **h6**

Non-standard tyres, different masts, optional equipment, etc. may result in different values.

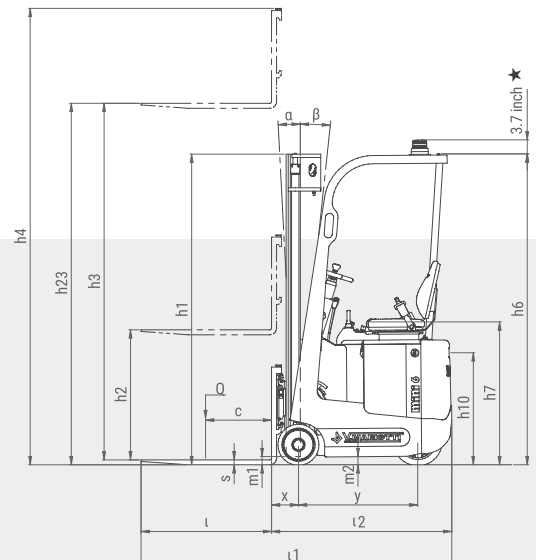
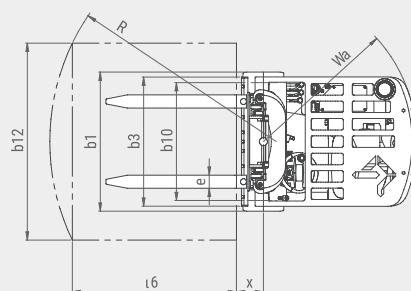

	1.1	Manufacturer			V.MARIOTTI S.r.l.	
	vvvv	Model			MINI 4	MINI 6
CHARACTERISTICS	1.3	Type of drive			electric	electric
	1.4	Operator type			driver sitting	driver sitting
	1.5	Load capacity/rated load	Q	lb	750	1100
	1.6	Load centre distance	c	in	24	24
	1.8	Load distance	x	in	6.4 ●	6.4 ●
	1.9	Wheel base min / max (adjustable)	y	in	27.6 / 30.4	27.6 / 30.4
WEIGHTS	2.1	Net weight incl. battery (see row 6.5)		lb	2866 ■	3086 ■
	2.2	Axle load. with load. front / rear		lb	3086 / 661	3704 / 705
	2.3	Axle load. without load. front / rear		lb	1389 / 1477	1433 / 1653
WHEELS	3.1	Tires: Solid pneumatic (SE). Cushion (V)			V / V	V / V
	3.2	Tire size front		in	9.8x5.1x7	9.8x5.1x7
	3.3	Tire size rear		in	11.8x4.7x8	11.8x4.7x8
	3.5	Wheels. number front/rear (◆ = driven wheels)			2 / 1 ◆	2 / 1 ◆
	3.6	Track width. front	b <sub>10</sub>	in	28.3	28.3
	DIMENSIONS	4.1	Tilt of mast/fork carriage forward/backward	α/β	<°	2° / 4°20'
4.2		Closed mast height	h <sub>1</sub>	in	74.8	74.8
4.3		Free lift	h <sub>2</sub>	in	\	\
4.4		forks lifting	h <sub>3</sub>	in	113	113
		Lifting height	h <sub>23</sub>	in	114	114
4.5		Height mast extended	h <sub>4</sub>	in	136.2	136.2
4.7		Height of overhead guard	h <sub>6</sub>	in	74.8	74.8
4.8		Seat height	h <sub>7</sub>	in	34.6	34.6
4.12		Coupling height	h <sub>10</sub>		26.8	26.8
4.19		Overall length	l <sub>1</sub>		74.6	74.6
4.20		Length including back of forks	l <sub>2</sub>	in	43 ●	43 ●
4.21		Overall width	b <sub>1</sub>	in	33.4	33.4
4.22		Fork dimensions	s/e/l	in	1.2x3.1x31	1.2x3.1x31
4.23		Forks carriage ISO 2328. Class/form A. B			ISO I	ISO I
4.24		Forks carriage width	b <sub>3</sub>	in	30.9	30.9
4.31		Floor clearance with load under mast	m <sub>1</sub>	in	2	2
4.32		Floor clearance centre wheelbase	m <sub>2</sub>	in	2	2
4.34		Right Angle Stack (for a 40" wide by 48" long pallet load)		in	94.7	94.7
4.35		Turning radius	W <sub>a</sub>	in	36.7 ▲	36.7 ▲
PERFORMANCE		5.1	Driving speed with/without load		mph	3.7 / 4
	5.2	Lift speed with/without load		fpm	41.3 / 45.3	37.4 / 45.3
	5.3	Lowering speed with/without load		fpm	59.1 / 47.2	59.1 / 47.2
	5.6	Max. drawbar pull. with/without load		lb	337 / 382	337 / 382
	5.7	Gradeability. with/without load		%	13 / 14	12 / 13
	5.8	Max Gradeability. with/without load		%	/	/
	5.10	Service brake			hydraulic	hydraulic
ELECTRIC SYSTEM	6.1	Drive motor rating S2 60 min.		kW	2	2
	6.2	Lift motor rating at S3 20%		kW	3	3
	6.4	Battery voltage/nominal capacity K5		V/Ah	24/270 - 24/375	24/375
	6.5	Battery weight		lb	562 ■ - 672	672 ■
OTHER	8.1	Type of drive control			AC MOSFET	AC MOSFET
	8.2	Working pressure for attachments		psi	1233	1378
	8.4	Sound pressure level at operator's ear			-	-

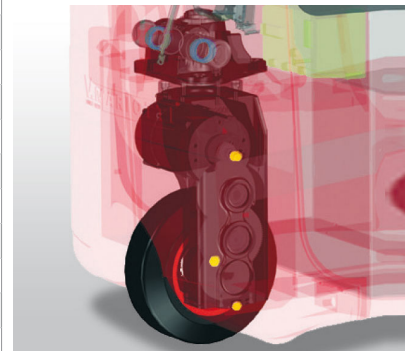

- ▲ with mast in vertical position
- included side-shift

Non-standard tires, different masts, optional equipment, etc. may result in different values.  
Right Angle Stack and Equal Intersecting Aisle dimensions (provided with a 48" long and 40" wide pallet load) allowing zero clearance.



**MONTREAL (Head office)**  
19151 A, Cruiickshank Avenue  
Baie-D'Urfé (Québec) H9X 3N9  
Phone: 418 694-4223  
Toll free: 1 866 421-4223  
info@elevex.ca | elevex.ca

**QUEBEC**  
1279, Paul-Émile Giroux St. Suite  
200 Québec (Québec) G1C 0X9

**SAGUENAY**  
2305, Alexis-Le-Trotteur  
St. Jonquière (Québec) G7X 9H8

