



MYCROS 10 - 13 RWD / FWD / AWD

- Traction: rear, front or all wheel
- Voltage 36V
- AC traction and pump motors
- Electronic Lift Control
- Cushion or Solid pneumatic tires
- Power Steering
- Integrated side-shift
- Lift height from 114" to 224"
- Curve Speed Control (CSC)
- Right Angle Stack 110.3"

MAST DETAILS MYCROS 10-13

HEIGHT		STANDARD INCL. SIDE-SHIFT				DUPLEX INCL. SIDE-SHIFT				TRIPLEX INCL. SIDE-SHIFT		
Lift height	h_{23}	114	126	150	165	114	126	150	165	171	189	224
Closed mast height	h_1	76.8	82.8	94.6	102.4	76.8	82.8	94.6	102.4	76.8	82.8	94.6
Height mast extended *	h_4	154.1	148	189.7	205.5	154.1	166.1	189.7	205.5	210.9	228.9	264.3
Free lift	h_2	-	-	-	-	58.2	64.2	76	83.9	58.2	64.2	76
Overall width RWD	b_1	35.8 SE - 36.2 V		38.6SE - 39 V		35.8 SE - 36.2 V		38.6SE - 39 V		38.6 SE - 39 V		
Overall width FWD-AWD	b_1	36.6 SE - 37 V				36.6 SE - 37 V				40.2 SE - 39 V		

* With Backrest

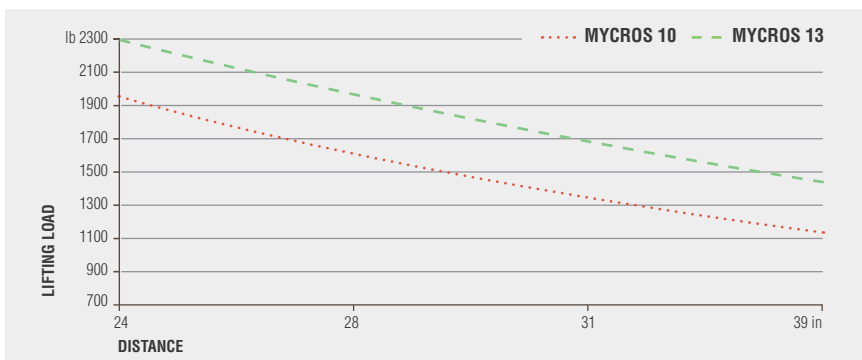

Data showed are not binding and are liable to variations.
The constructor reserves the right of changes without notice.

★ On demand installation of the strobo light under the height of the overhead guard **h6**

Non-standard tyres, different masts, optional equipment, etc. may result in different values.

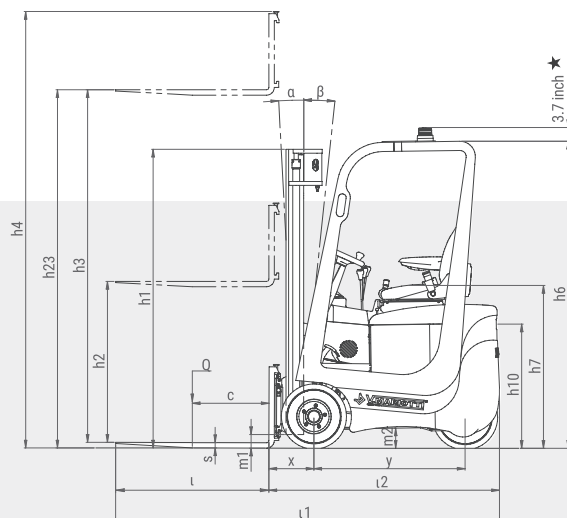
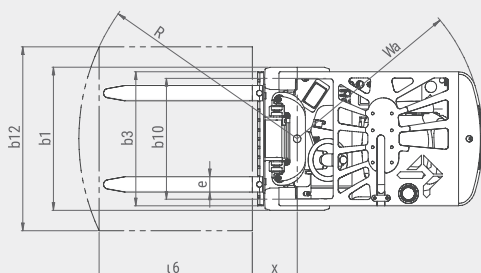

	1.1			V.MARIOTTI S.r.l.			V.MARIOTTI S.r.l.				
	Manufacturer			MYCROS 10 RWD	MYCROS 10 FWD	MYCROS 10 AWD	MYCROS 13 RWD	MYCROS 13 FWD	MYCROS 13 AWD		
CHARACTERISTICS	1.2	Model									
	1.3	Type of drive		electric	electric	electric	electric	electric	electric		
	1.4	Operator type		driver sitting	driver sitting	driver sitting	driver sitting	driver sitting	driver sitting		
	1.5	Load capacity/rated load	Q	lb	1950	1950	1950	2300	2300	2300	
	1.6	Load centre distance	c	in	24	24	24	24	24	24	
	1.8	Load distance	x	in	11.4 ●	11.4 ●	11.4 ●	11.4 ●	11.4 ●	11.4 ●	
	1.9	Wheel base min / max (adjustable)	y	in	37.8 / 41.3	37.8 / 41.3	37.8 / 41.3	37.8 / 41.3	37.8 / 41.3	37.8 / 41.3	
	WEIGHTS	2.1	Net weight incl. battery (see row 6.5)		lb	4894 ■	5115 ■	5335 ■	5622 ■	5842 ■	5842 ■
		2.2	Axle load. with load. front / rear		lb	6063 / 1036	6261 / 1058	6393 / 1146	7430 / 1058	7628 / 1080	7540 / 1168
2.3		Axle load. without load. front / rear		lb	2403 / 2491	2535 / 2579	2579 / 2756	2646 / 2976	2844 / 2998	2734 / 3109	
WHEELS	3.1	Tires: Solid pneumatic (SE). Cushion (V)			SE - V	SE - V	SE - V	SE - V	SE - V	SE - V	
	3.2	Tire size front		in	145x60-9 16.3x6x11.3	145x60-9 16.3x6x11.3	145x60-9 16.3x6x11.3	145x60-9 16.3x6x11.3	145x60-9 16.3x6x11.3	145x60-9 16.3x6x11.3	
	3.3	Tire size rear		in	145x60-9 16.3x6x11.3	145x60-9 16.3x6x11.3	145x60-9 16.3x6x11.3	145x60-9 16.3x6x11.3	145x60-9 16.3x6x11.3	145x60-9 16.3x6x11.3	
	3.5	Wheels. number front/rear (◆ = driven wheels)			2 / 1 ◆	2 ◆ / 1	2 ◆ / 1 ◆	2 / 1 ◆	2 ◆ / 1	2 ◆ / 1 ◆	
	3.6	Track width. front	b ₁₀	in	30.1 SE - 30.2 V	30.9 SE - 31 V	30.9 SE - 31 V	30.1 SE - 30.2 V	30.9 SE - 31 V	30.9 SE - 31 V	
	DIMENSIONS	4.1	Tilt of mast/fork carriage forward/backward		α/β	<°	2° 50' / 6°	2° 50' / 6°	2° 50' / 6°	2° 50' / 6°	2° 50' / 6°
4.2		Closed mast height		h ₁	in	82.8	82.8	82.8	82.8	82.8	
4.3		Free lift		h ₂	in	\	\	\	\	\	
4.4		forks lifting		h ₃	in	124.6	124.6	124.6	124.6	124.6	
		Lifting height		h ₂₃	in	126	126	126	126	126	
4.5		Height mast extended		h ₄	in	146	146	146	146	146	
4.7		Height of overhead guard		h ₆	in	78.7	78.7	78.7	78.7	78.7	
4.8		Seat height		h ₇	in	38.6	38.6	38.6	38.6	38.6	
4.12		Coupling height		h ₁₀		31.9	31.9	31.9	31.9	31.9	
4.19		Overall length		l ₁		98.3	98.3	98.3	98.3	98.3	
4.20		Length including back of forks		l ₂	in	58.8 ●	58.8 ●	58.8 ●	58.8 ●	58.8 ●	
4.21		Overall width		b ₁	in	35.8 SE - 36.2 V	36.6 SE - 37 V	36.6 SE - 37 V	35.8 SE - 36.2 V	36.6 SE - 37 V	36.6 SE - 37 V
4.22		Fork dimensions		s/e/l	in	1.4x3.9x39	1.4x3.9x39	1.4x3.9x39	1.4x3.9x39	1.4x3.9x39	1.4x3.9x39
4.23		Forks carriage ISO 2328. Class/form A. B				ISO II/A	ISO II/A	ISO II/A	ISO II/A	ISO II/A	ISO II/A
4.24		Forks carriage width		b ₃	in	34.4	34.4	34.4	34.4	34.4	34.4
4.31		Floor clearance with load under mast		m ₁	in	3.5	3.5	3.5	3.5	3.5	3.5
4.32		Floor clearance centre wheelbase		m ₂	in	4.3	4.3	4.3	4.3	4.3	4.3
4.34		Right Angle Stack (for a 40" wide by 48" long pallet load)			in	110.3	110.3	110.3	110.3	110.3	110.3
4.35		Turning radius		W _a	in	47.6 ▲	47.6 ▲	47.6 ▲	47.6 ▲	47.6 ▲	47.6 ▲
PERFORMANCE		5.1	Driving speed with/without load		mph	5.6 / 5.7	5.6 / 5.9	5.6 / 5.9	5.6 / 5.7	5.6 / 5.9	5.6 / 5.9
		5.2	Lift speed with/without load		fpm	57.1 / 74.8	57.1 / 74.8	57.1 / 74.8	55.1 / 74.8	55.1 / 74.8	55.1 / 74.8
	5.3	Lowering speed with/without load		fpm	68.9 / 51.2	68.9 / 51.2	68.9 / 51.2	70.9 / 51.2	70.9 / 51.2	70.9 / 51.2	
	5.6	Max. drawbar pull. with/without load		lb	697 / 731	697 / 731	697 / 731	674 / 719	674 / 719	674 / 719	
	5.7	Gradeability. with/without load		%	13 / 18	14 / 18	14 / 18	10 / 16	11 / 18	11 / 18	
	5.8	Max Gradeability. with/without load		%	17 / 25	18 / 25	18 / 25	15 / 24	16 / 24	16 / 24	
	5.10	Service brake				hydraulic	hydraulic	hydraulic	hydraulic	hydraulic	
	6.1	Drive motor rating S2 60 min.		KW	5	3.5 x 2	3.5 x 2 + 5	5	3.5 x 2	3.5 x 2 + 5	
	ELECTRIC SYSTEM	6.2	Lift motor rating at S3 20%		kW	6.5	6.5	6.5	6.5	6.5	6.5
		6.4	Battery voltage/nominal capacity K5		V/Ah	36/315 - 36/500	36/375 - 36/500	36/375 - 36/500	36/500	36/500	36/500
6.5		Battery weight		lb	882 ■ - 1257	1014 ■ - 1257	1014 ■ - 1257	1257 ■	1257 ■	1257 ■	
8.1		Type of drive control		yes/ no		AC MOSFET	AC MOSFET	AC MOSFET	AC MOSFET	AC MOSFET	
OTHER	8.2	Working pressure for attachments		psi	2248	2248	2248	2756	2756	2756	
	8.4	Sound pressure level at operator's ear			-	-	-	-	-	-	

▲ with mast in vertical position
● included side-shift

Non-standard tires, different masts, optional equipment, etc. may result in different values.
Right Angle Stack and Equal Intersecting Aisle dimensions (provided with a 48" long and 40" wide pallet load) allowing zero clearance.



MONTREAL (Head office)
19151 A, Crueckshank Avenue
Baie-D'Urfé (Québec) H9X 3N9
Phone: 418 694-4223
Toll free: 1 866 421-4223
info@elevex.ca | elevex.ca

QUEBEC
1279, Paul-Émile Giroux St. Suite
200 Québec (Québec) G1C 0K9

SAGUENAY
2305, Alexis-Le-Trotteur
St. Jonquière (Québec) G7X 9H8

