

NOBLELIFT

NOBLELIFT INTELLIGENT EQUIPMENT CO., LTD

ISO9001 / ISO14001

FE3D16-20N

3-Wheels
front drive
Electric Forklift

1600 -2000Kg

NEW MODEL RANGE



NEW / *Noblelift Products*
ARRIVAL



ELEVEX™
Material Handling Solutions

Type sheet for industrial truck acc. to VDI 219

Distinguishing mark

1.2	Manufacturer's type designation		FE3D16N	FE3D18N	FE3D20N
1.3	Drive :electric(battery or mains),diesel,petrol gas ,manual)		electric	electric	electric
1.4	Type of operation(hand,pedestrian,standing,seated,order-picker)		seated	seated	seated
1.5	Load capacity/rated load	Q(kg)	1600	1750	2000
1.6	Load centre distance	C(mm)	500	500	500
1.8	Load distance,centre of drive axle to fork	x(mm)	372	377	377
1.9	wheelbase	y(mm)	1360	1360	1490

Weight

2.1	Service weight incl. battery(see line 6.5)	kg	3100	3260	3420
2.2	Axle loading ,laden front/rear	kg	4200/500	4550/510	4880/540
2.3	Axle loading,unladen front/rear	kg	1490/1610	1610/1650	1670/1750

Tires, chassis

3.1	Type:solid rubber,superelastic,pneumatic,polyurethane		superelastic	superelastic	superelastic
3.2	Tyres size,front		18X7-8	18X7-8	200X50-10
3.3	Tyres size,rear		15X4 ³ -8	15X4 ³ -8	15X4 ³ -8
3.5	Wheels,number front/rear(x=driven wheels)		2×/2	2×/2	2×/2
3.6	Track width,front	b10(mm)	960	960	984
3.7	Track width,rear	b11(mm)	180	180	180

Dimensions

4.1	Mast/fork carriage tilt forward/backward	$\alpha/\beta(^{\circ})$	5/7	5/7	5/7
4.2	lowered mast height	h1(mm)	2008	2008	2008
4.3	Free lift	h2(mm)	125	125	125
4.4	Lift height	h3(mm)	3000	3000	3000
4.5	Extended mast height	h4(mm)	3981	3981	3981
4.7	Overhead load guardheight	h6(mm)	2075	2075	2075
4.8	Seat height/standing height	h7(mm)	1030	1030	1030
4.12	Coupling height	h10(mm)	465	465	465
4.19	Overall length	l1(mm)	2845	3000	3130
4.20	Length to face of forks	l2(mm)	1925	1930	2060
4.21	Overall width	b1(mm)	1135	1135	1135
4.22	Fork dimensions	s/e/l(mm)	35/100/920	40/120/1070	40/120/1070
4.24	Fork carriage width	b3(mm)	1040	1040	1040
4.31	Ground clearance ,laden,under mast	m1(mm)	123	123	123
4.32	Ground clearance,centre of wheelbase	m2(mm)	105	105	105
4.33	Aisle width for pallets 1000×1200 crossways	Ast(mm)	3122	3127	3257
4.34	Aisle width for pallets 800×1200 lengthways	Ast(mm)	3322	3327	3357
4.35	Turning radius	Wa(mm)	1550	1550	1680

Performance

5.1	Travel speed,laden/unladen	km/h	14/15	14/15	13/15
5.2	Lift speed,laden/unladen	m/s	0.32/0.42	0.30/0.42	0.30/0.42
5.3	lowering speed,laden/unladen	m/s	<600	<600	<600
5.5	Drawbar pull ,laden/unladen S2 60 min	N	—	—	—
5.6	Max.drawbar pull ,laden/unladen S2 5 min	N	13000	14000	16000
5.7	Max.Gradient performance,laden/unladen S2 5 min	%	15/20	15/20	13/18
5.10	Service brake		Hydraulic	Hydraulic	Hydraulic

Electric-engine

6.1	Drive motor rating S2 60 min	kW	4.5X2	4.5X2	4.5X2
6.2	Lift motor rating at S3 15%	kW	8.6	8.6	8.6
6.3	Battery standard		DIN	DIN	DIN
6.4	Battery voltage,nominal capacity K5	V/Ah	48/455 48/490(optional) 48/560(optional)	48/455 48/490(optional) 48/560(optional)	48/560 48/630(optional)
6.5	Battery weight	kg	800	800	950
6.6	Battery dimensions l/w/h	mm	980X538X670	980X538X670	980X668X670

Additional data

8.1	Type of drive control		AC	AC	AC
8.2	Operating pressure for attachments	Mpa	17.5	17.5	17.5
8.3	Oil volume for attachments	l/min	36	36	36
8.4	Sound level at driver's ear according to EN 12 053	dB(A)	73	73	73

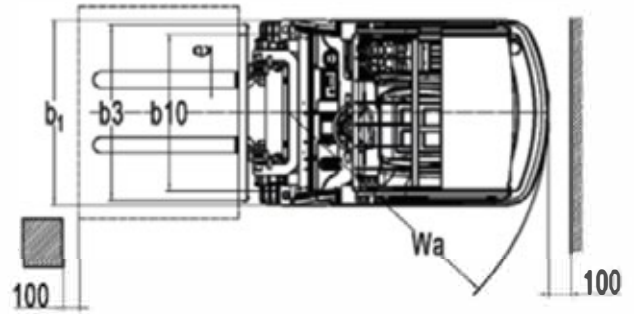
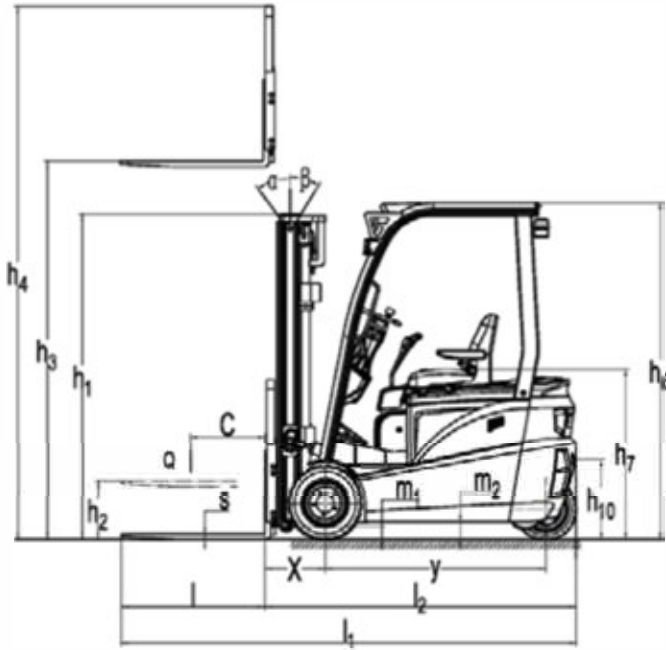

Mast table FE3D16-20N

Designation	Lift height h3(mm)	Free Lift h2(mm)	Closed mast height h1(mm)	Extended mast height h4(mm)	Tilt forward/backward $\alpha/\beta(^{\circ})$	Capacity table(kg) C=500mm without sideshift single tyres		
						FE3D16N	FE3D18N	FE3D20N
Two-stage ZT	2500	125	1758	3481	5/7	1600	1800	2000
	2700	125	1858	3681	5/7	1600	1800	2000
	3000	125	2008	3981	5/7	1600	1800	2000
	3300	125	2158	4281	5/7	1600	1800	2000
	3500	125	2258	4481	5/7	1600	1800	2000
	3700	125	2358	4681	5/7	1600	1800	2000
	4000	125	2558	4981	3/5	1500	1750	1900
	4300	125	2708	5281	3/5	1450	1650	1800
	5000	125	3083	5981	3/5	1000	1100	1400
Two-stage ZZ	2500	793	1758	3474	5/7	1600	1800	2000
	2700	893	1858	3674	5/7	1600	1800	2000
	3000	1043	2008	3974	5/7	1600	1800	2000
	3300	1193	2158	4274	5/7	1600	1800	2000
	3500	1293	2258	4474	5/7	1600	1800	2000
	3700	1393	2358	4674	5/7	1600	1800	2000
	4000	1593	2558	4974	5/7	1500	1750	1900
	4300	1743	2708	5274	3/5	1450	1650	1800
	5000	2118	3083	5974	3/5	1000	1100	1400
Three-stage DZ	4000	988	1953	4980	3/5	1500	1750	1900
	4350	1113	2078	5329	3/5	1450	1600	1700
	4500	1163	2128	5479	3/5	1400	1450	1600
	4800	1263	2228	5779	3/5	1200	1300	1400
	5000	1363	2328	5979	3/5	1050	1100	1300
	6000	1513	2478	6479	3/5	800	900	1000
	1713	2678	6565	3/5	600	650	700	



MONTREAL (Head office)
 19151 A, Cruickshank Avenue
 Baie-D'Urfé (Québec) H9X 3N9
 Phone: 418 694-4223
 Toll free: 1 866 421-4223
info@elevex.ca
elevex.ca

QUEBEC
 1279, Paul-Émile Giroux St. Suite 200
 Québec (Québec) G1C 0K9

SAGUENAY
 2305, Alexis-Le-Trotteur St.
 Jonquière (Québec) G7X 9H8

