

FE4P40-55Q

Four wheel Li-ion Electric Forklift

NEW *Noblelift Products*
ARRIVAL



FE4P40-55Q

Innovative Solutions, New Power

- Q series lithium electric forklift launched 4-5 tons model, referred to as FE4P40-50Q.
- The standard configuration is lithium iron phosphate (LFP) battery with efficient fast charging. Optional different battery capacities for various of working requirements; the standard configuration is 80V412Ah, optional 80V554Ah.
- Standard full AC control system and optional fleet management system. Standard REMA/Anderson connection for charging, optional automotive type intelligent plug-in high frequency charging technology.
- Standard full AC control system and optional fleet management system. Standard REMA/Anderson layout advantage of Li-ion electric forklift, so that the truck's weight is light and gravity center is optimized, and the overall energy consumption is effectively improved.



Reliable quality, safer and comfortable

- The mast system, front and rear axles as well as the durability of chassis are similar to traditional IC forklift.
- Big diameter tyres with better performance for outdoor applications, and comfortable driving experience, solid tyres as standard configuration
- Standard with turning deceleration function, safer driving



Ergonomic design, comfortable and reliable

- Long handle lever, good braking effect, less effort and easier to operate
- Ratchet parking brake lever, more reliable, not slide for 15% ramp parking
- Steering wheel and seat can be adjusted back and forth, more comfortable
- U-shape design of steering wheel, front-located multi-way valve operating device makes the operation effortless and comfortable
- Wide view for mast, making operation more comfortable
- New large screen LED instrument, good visibility and intuitive reading
- Standard with turning deceleration function, safer driving

Ratchet-type parking brake allows the truck stay at the slope of 15% without safety concern.



LED meter, good visibility, simple and intuitive



U design of steering wheel, front-located multi-way valve operating device makes the operation effortless and com fortble.



Simplified structure, easy for maintenance

- Side out lithium design, battery replacement convenient and quick
- Charging form is flexible and optional, suitable for various operation scenarios
- Open design for controller and lifting motor, more convenient maintenance

Side out lithium design, battery replacement convenient and quick



Open design for controller and lifting motor, more convenient maintenance



Charging form is flexible and optional, suitable for various operation scenarios



Standard:
REMA/Anderson
plug-in.

Optional:
automotive type intelligent plug-in charging gun
with high frequency charging technology.
*Note: press the "stop" button of the charger
before pulling the gun.*



ELEVEXTM
Material Handling Solutions

Standard Lithium power, high efficiency



All lithium-iron batteries are equipped built-in battery management system(BMS) that manages all important data during charging and discharging. The management of the battery by BMS can ensure the safety of the battery throughout its life cycle. **Lithium-iron batteries have been certified for safe transportation(by air and sea)and operating standards.** BMS communicates with the truck management system through CAN. CAN protocol CAN monitor the battery and diagnose and repair the battery through specific software.

Lithium battery advantages

FAST CHARGING Charge your battery whenever and wherever you need

ENVIRONMENT-FRIENDLY High cost performance

SAFETY Efficient, Maintenance-free

Operation Cost

Li-ion electric forklift VS lead acid electric forklift VS diesel forklift

- 1. **Lithium battery**
- 2. **Lead acid battery in productivity**
- 3. **Lead acid battery in life cycle**
- 4. **Lead acid battery in total value**

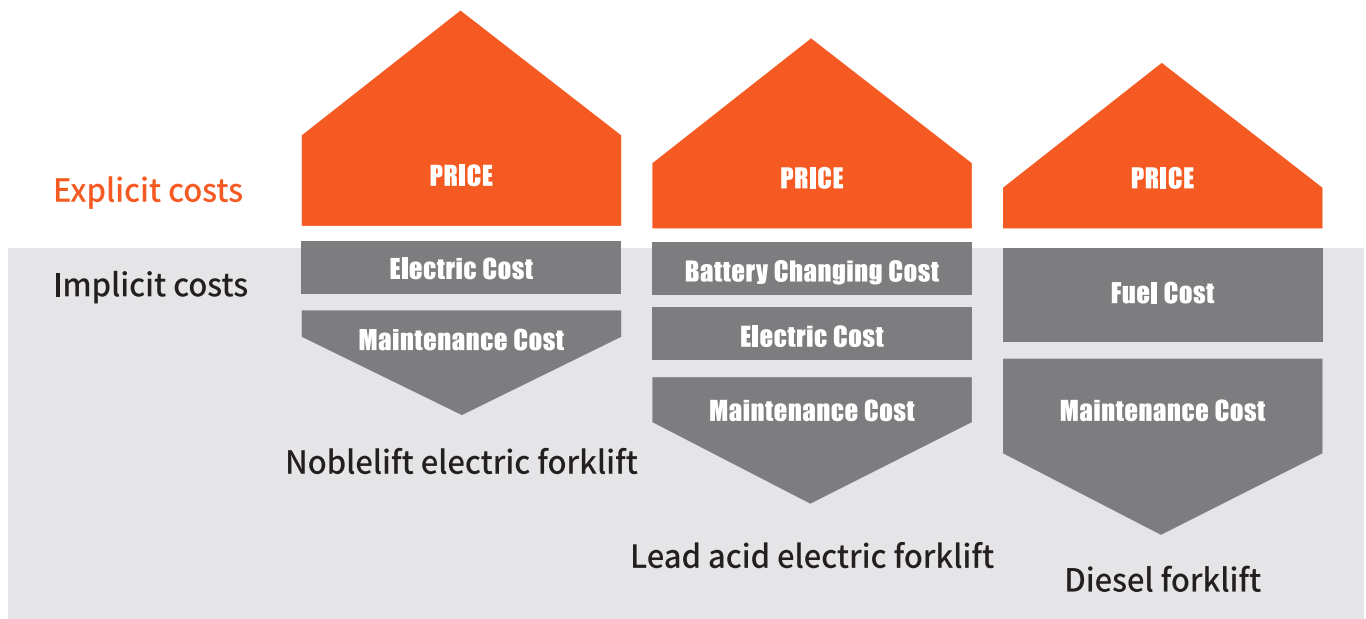

FE4P40-50Q Battery Balance Weight Type Forklift

Identification	1.1	Manufacture(abbreviation)		Noblelift			
	1.2	Manufacturer's type designation		FE4P40Q	FE4P45Q	FE4P50Q	FE4P50QL
	1.3	Drive:electric(battery or mains),diesel,petrol gas,manual		Electric			
	1.4	Type of operation(hand,pedestrian,standing,seated,order-picker)		Seated			
	1.5	Load capacity/rated load	Q(kg)	4000	4500	5000	
	1.6	Load centre distance	C(mm)	500			600
	1.8	Load distance,centre of drive axle to fork	x(mm)	563			568
	1.9	wheelbase	y(mm)	1950			
	Weights	2.1	Service weight incl. battery(see line 6.5)	kg	6200	6500	6950
2.2		Axle loading ,laden front/rear	kg	9180/1020	9850/1150	10610/1360	10800/1600
2.3		Axle loading,unladen front/rear	kg	2950/3250	2960/3540	2750/4200	2800/4600
Wheels, Chassis	3.1	Tyres:solid rubber,superelastic,pneumatic,polyurethane		Solid rubber			
	3.2	Tyres size,front		250-15			28×12.5-15
	3.3	Tyres size,rear		23×9-10			
	3.5	Wheels,number front/rear(×=driven wheels)		2×2			
	3.6	Track width,front	b10(mm)	1200			1185
	3.7	Track width,rear	b11(mm)	1125			
	Basic Dimensions	4.1	Mast/fork carriage tilt forward/backward	$\alpha/\beta(^{\circ})$	6/10		
4.2		lowered mast height	h1(mm)	2250			
4.3		Free lift	h2(mm)	150			
4.4		Lift height	h3(mm)	3000			
4.5		Extended mast height	h4(mm)	4117			
4.7		Overhead load guard height	h6(mm)	2265			
4.8		Seat height/standing height	h7(mm)	1200			
4.12		Coupling height	h10(mm)	490			
4.19		Overall length	l1(mm)	3962			3967
4.20		Length to face of forks	l2(mm)	2892			2897
4.21		Overall width	b1(mm)	1500			
4.22		Fork dimensions	s/e/l(mm)	50 / 150/ 1070			55 / 150/ 1070
4.24		Fork carriage width	b3(mm)	1380			
4.31		Ground clearance ,laden,under mast	m1(mm)	135			
4.32		Ground clearance,centre of wheelbase	m2(mm)	165			
4.33		Aisle width for pallets 1000×1200 crossways	Ast(mm)	4453			4458
4.34		Aisle width for pallets 800×1200 lengthways	Ast(mm)	4653			4658
4.35	Turning radius	Wa(mm)	2690				
Performance Data	5.1	Travel speed,laden/unladen	km/h	14/15			
	5.2	Lift speed,laden/unladen	m/s	0.3/ 0.42			0.3/ 0.4
	5.3	lowering speed,laden/unladen	m/s	0.38/ 0.3			
	5.5	Drawbar pull,laden/unladen S2 60 min	N	5800/6200	6000/6500	6200/6650	6200/6650
	5.6	Max.drawbar pull ,laden/unladen S2 5 min	N	17500/17000	17800/17500	18500/18000	
	5.7	Max.Gradient performance,laden/unladen S2 5 min	%	16 / 20	15 / 20		
	5.10	Service brake		Mechanical			
	E-Motor	6.1	Drive motor rating S2 60 min	kW	20		
6.2		Lift motor rating at S3 15%	kW	26			
6.3		Battery standard		Lion			
6.4		Battery voltage,nominal capacity K5	V/Ah	80/412(80/554)			
6.5		Battery weight	kg	330/420			
6.6		Battery dimensions l/w/h	mm	1200/810/610			
Other Details	8.1	Type of drive control		AC			
	8.2	Operating pressure for attachments	MPa	18.5			
	8.3	Oil volume for attachments	l/min	65			
	8.4	Sound level at driver's ear according to EN 12053	dB(A)	75			

Mast Table FE4P40-50Q

Designation	Lift height h3 (mm)	Free Lift height h2 (mm)	Closed mast height h1 (mm)	Extended mast height h4 (mm)	Tilt forward/backward $\alpha / \beta(^{\circ})$	Capacity table(kg)C=500 without sideshift inle superelastic tyre				
						FE4P40Q	FE4P45Q	FE4P50Q	FE4P50QL	
Two-stage ZT	2500	150	2010	3617	6/10	4000	4500	5000	5500	
	2700	150	2110	3817	6/10	4000	4500	5000	5500	
	3000	150	2260	4117	6/10	4000	4500	5000	5500	
	3300	150	2410	4417	6/10	4000	4500	5000	5500	
	3500	150	2510	4617	6/10	4000	4500	5000	5500	
	3600	150	2560	4717	6/10	4000	4500	5000	5500	
	3700	150	2610	4817	6/10	4000	4400	4900	5400	
	4000	150	2810	5117	6/6	4000	4300	4750	5100	
	4500	150	3060	5617	6/6	3700	3900	4250	5000	
	4700	150	3160	5817	6/6	3600	3800	4100	4400	
Two-stage ZZ	2500	1350	2010	3612	6/10	4000	4500	5000	5500	
	2700	1450	2110	3812	6/10	4000	4500	5000	5500	
	3000	1600	2260	4112	6/10	4000	4500	5000	5500	
	3300	1750	2410	4412	6/10	4000	4500	5000	5500	
	3500	1850	2510	4612	6/10	4000	4500	5000	5500	
	3600	1900	2560	4712	6/10	4000	4500	5000	5500	
	3700	1950	2610	4812	6/10	4000	4400	5000	5400	
	4000	2100	2810	5112	6/6	4000	4300	4800	5200	
	Three-stage DZ	3700	917	1995	4808	6/10	4000	4400	4900	5400
		4000	1017	2095	5108	6/6	4000	4300	4750	5200
4350		1123	2210	5458	6/6	3800	4000	4450	4900	
4500		1182	2260	5608	6/6	3700	3900	4250	4700	
4800		1282	2360	5908	6/6	3500	3700	4100	4500	
5000		1397	2475	6108	6/6	3400	3600	4000	4400	
5500		1562	2640	6608	3/6	3000	3200	3600	4000	
6000	1807	2885	7068	3/6	2800	3000	3400	3800		

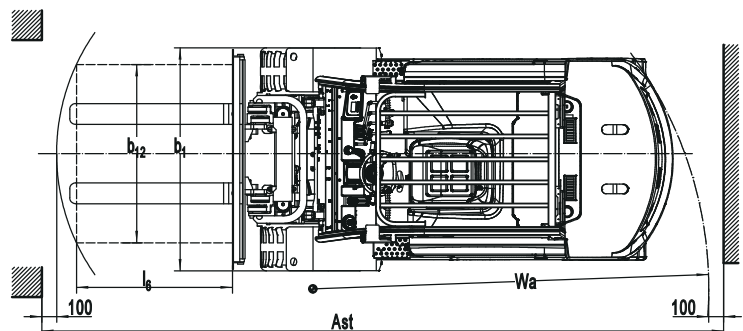
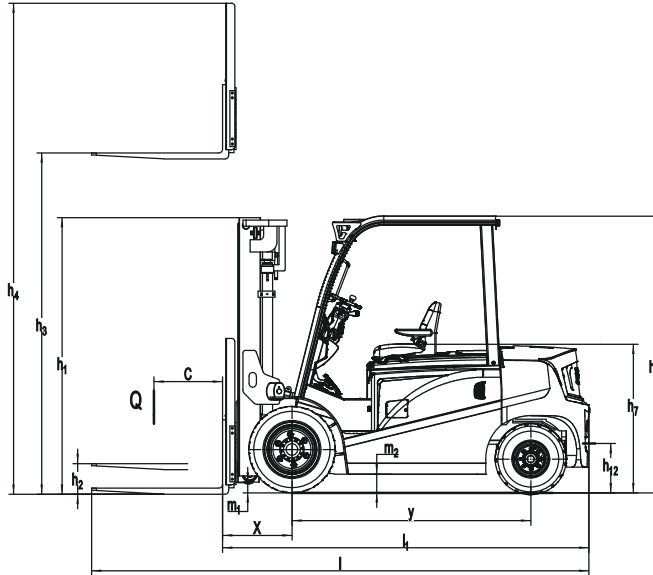

Working Together For A Shared Future



Montreal | Quebec | Saguenay

elevex.ca



MONTREAL (Head office)

19151 A, Cruickshank Avenue
Baie-D'Urfé (Québec) H9X 3N9

Phone: 418 694-4223

Toll free: 1 866 421-4223

QUEBEC

1279, Paul-Émile Giroux St. Suite 200
Québec (Québec) G1C 0K9

SAGUENAY

2305, Alexis-Le-Trotteur St.
Jonquière (Québec) G7X 9H8

info@elevex.ca