

PTE15N SC

Electric Scale Pallet Truck



-  **Small Size**
-  **Low Self Weight**
-  **Lithium Battery**
-  **Smart Design**
-  **Best Cost Performance Ratio**



PRODUCT INTRODUCTION

As a new member in the family of **EDGE**, on the basis of high cost performance ratio, the **PTE15N SC** electric scale pallet truck, provides a perfect solution for the material handling applications in which the material needs weighing, such as the supermarkets or distribution centers and so on. Different from the traditional weighing operation mode, the scale pallet truck of **EDGE** series **combines material handling and weighing intelligently**, improving the working efficiency and reducing the labor intensity of the operator at the same time. The scale pallet truck of **EDGE** series has many advanced functions that the conventional economic electric products can not match. For example, the function of speed reduction at turning, PIN-Panel Access, driving with handle in vertical position (Pin-wheel drive), fast charging and opportunity charging Li-ion battery, and high precision weighing display with option of printer.



Intelligent Big Screen



LCD digital numbers are upto 30mm in height, data can clearly be seen, there is a background light source, suitable for applications in dark environments.



Cumulative Finction

Each batch of products can be counted into, the final cumulative calculation, to avoid overload.

Function Key can be Pressed

When the finger presses the function key of the display, the operation sense of pressing the key can be clearly felt even if wearing gloves, so as to improve the accuracy of operation.

The Unit Switch

Weight unit can be changed between lb and kg to meet customer's different needs.

Multiple Function Keys

Many functions (including NET weight, gross weight), to meet customer's weighing requirements.

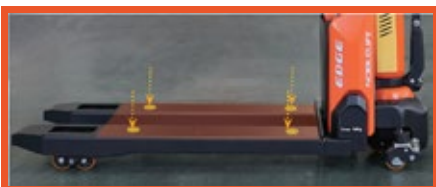

High Precision Sensor

The accuracy of the four sensors is 3kg, the min. measuring unit is 0.5kg



Thermal Printer

Thermal printer, with low voltage protection function, print weighing values at any time without impact to the battery life.



Weighing Terminal with Built-in Rechargeable Battery

The built-in 4.5 large capacity rechargeable battery, which is durable, easy to charge, no need to be disassembled, with low power consumption. When fully charged, the battery can be used for 3-6 months (turn it off when its not in use).

The **PSE15NSC** electric pallet truck with scale is more suitable for the market and meet the needs of different customers. it adopts 650W drive unit and high precision weighing system to improve the handling of goods and at the same time can accurately weigh them, which is completely suitable for the requirements of supermarkets, logistics centers and so on.



Ergonomic & Smart Tiller Design



The tiller of the truck with ergonomic design has comfortable soft grips the comfort daily operation. All buttons are big and can be easily reached by operators even in case of working in gloves.

Integrated PIN CODE panel with LCD display for smart control and operation. The tiller of the truck is supported by the **air spring** and the tiller returns to its vertical position smoothly.

Speed reduction at different angles as well as function of active tiller in its up-right position.

Standard for PTE15N SE



Front

- Emergency-reverse & horn buttons
- Dual butterfly-style thumb driving controls
- Electric lifting & lowering

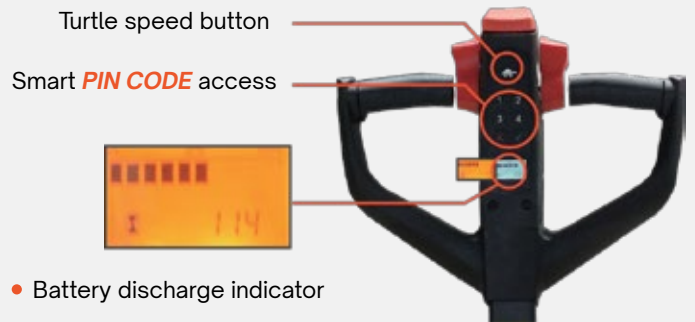

Back

- Battery discharge indicator
- Operator hour counter
- On-board diagnostic via error codes

Robust & Smart Design of Chassis



The frame of truck is surrounded by stamped steel elements making the truck looking different and also ensuring **protection** of components.



Forks of the truck with shape of easy entrance and exit from pallets. Full length double sided C-shape **reinforcements** of forks significantly increases strength and **rigidity** of frame.



Strong steel apron protects the operator's feet during work and secures the truck's components from collisions with objects.

Capacity upto **1500kg** and ability to overcome ramps upto **4/16%** (laden/unladen) makes the truck suitable for work in loading docks and on delivery operations in different conditions.



Maintenance Friendly

Drive motor with intelligent Curtis control

For the pallet trucks there are no hoses or pipes used in the hydraulic lifting circuit which significantly improves **reliability** and reduces the amount of potential problems related to leakages through connectors or their seals.



Curtis



These trucks are equipped with **CURTIS** controllers, CAN-bus technology makes the diagnostic and troubleshooting easier.

The use of proved and certified components helps to ensure the conformity to international safety standards with all the supporting documents available as required by law.

Each battery can be diagnosed via CAN connection with help of special software tool, the software can provide information about the battery condition, such as balance of cells, amount of charging/discharging cycles, current, energy consumption, temperature, charging/dischargin parameters voltage of every cell, faults and alarms, settings of timing for automatic turn off.

Smart Lithium Battery

Optional different battery capacities from 20Ah to 36Ah for various applications.



The **PTE15N SC** are equipped with maintenance-free Li-ion batteries, optional capacities for various applications are available, with its fast charging and oppourtunity charging features (charge whenever you want and as long as time allows) the operation time can be extended significantly.



Light weight of the battery (max. 8kg) and the way of fast battery replacement allows even a female operator to double the work time within seconds. The light weight of the batteries can be achieved through use of li-ion battery type with high ratio of energy density to its self-weight.



Socket on battery case for easy battery charging without necessity to take the battery out. The **PTE15N SC** remains unpowered while charger is disconnected from the power outlet, therefore, the safety is ensured and the possibility to damage the charger is excluded.



The position of the battery inside the battery compartment is fast and easy thanks to specially designed battery guild system.



min. **2.5** hours charge

Excellent working time

All Li-ion batteries are equipped with on-board Battery Management System (BMS), which provides mandatory control of all important parameters of the battery during charging and operation. With this control, the safety of Li-ion battery during the whole life-cycle is guaranteed. The Li-ion batteries are certified according to international safety transportation (by sea and by air) and operation standards. The BMS communicates with control system of the truck via CAN, the support of the CAN protocols allows to monitor the condition of the battery and make its diagnosis with help of special software which is available for our partners.



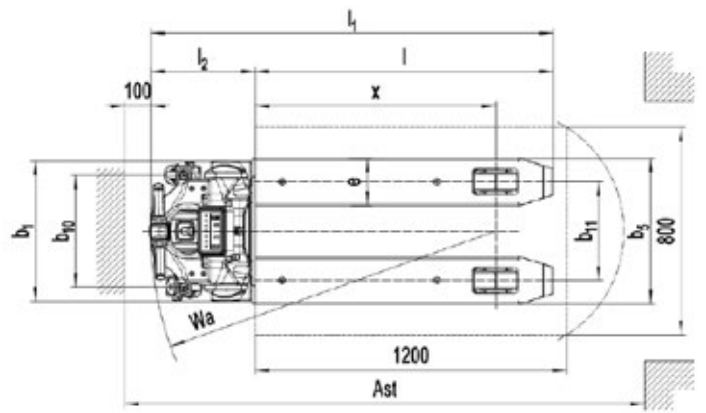
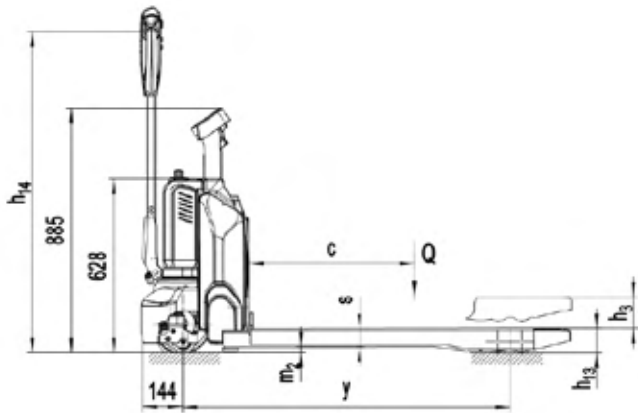

TYPE SHEET FOR INDUSTRIAL TRUCK ACC. TOVDI 2198

Distinguishing Mark

1.2	Manufacturer's		PTE15N SC
1.3	Drive		Battery
1.4	Operator type		Pedestrian
1.5	Load capacity / rated load	Q (t)	1.5
1.6	Load centre distance	c (mm)	600
1.8	Load distance, centre of drive axle to fork	x (mm)	928
1.9	Wheelbase	y (mm)	1183

Weight

2.1	Service weight	kg	180	185
2.2	Axle loading laden front / rear	kg	472/1208	476/1209
2.3	Axle loading unladen front / rear	kg	121/59	121/64

Tyres | Chasis

3.1	Tyres	kg	Polyurethane (PU)	
3.2	Tyre size, front	Øxw (mm)	Ø 210x70	
3.3	Tyre size, rear	Øxw (mm)	Ø 80x93 (Ø 80x70)	
3.4	Additional wheels (dimensions)	Øxw (mm)	-/Ø 80x30	
3.5	Wheels, number front/rear (x=driven wheels)		1x/ 2(1x/4) or 1x +2/ 2(1x +2/ 4)	
3.6	Tread, front	b10 (mm)	-/430	
3.7	Tread, rear	b11 (mm)	380	525

Dimensions

4.4	Lift	h3 (mm)	115	
4.9	Height of tiller in drive position min./max.	h14 (mm)	740 / 1162	
4.15	Height, lowered	h13 (mm)	88	
4.19	Overall length	l1 (mm)	1560	
4.20	Length to face of forks	l2 (mm)	410	
4.21	Overall width	b1 (mm)	540	
4.22	Fork dimensions	s/e/l (mm)	64/182/1150	
4.25	Distance between fork arms	b5 (mm)	562	707
4.32	Ground clearance, centre of wheelbase	m2 (mm)	21	

4.34	Aisle width for pallets 800x1200 lengthways	Ast (mm)	2000
4.35	Turning radius	Wa (mm)	1387

Performance Data

5.1	Travel speed, laden / unladen	km/h	4.2 / 4.4
5.2	Lift speed, laden / unladen	m/s	0.015 / 0.022
5.3	Lowering speed, laden / unladen	m/s	0.05 / 0.04
5.8	Max. gradeability laden / unladen	%	6 / 16
5.10	service brake		Electromagnetic

Electric Engine

6.1	Drive motor rating S2 60min	kW	0.65
6.2	Lift motor rating at S3 10%	kW	0.50
6.3	Battery acc. to DIN 43531/35/36 A, B, C		No
6.4	Battery voltage, nominal capacity K5	V/Ah	24/20 (20/30 34/36)
6.5	Battery weight	kg	4.6
6.6	Energy consumption acc. to VDI cycle	kWh/h	0.19

Additional Data

8.1	Type of drive control		DC speed control
8.4	Sound level at driver's ear acc. to EN 12053	dB(A)	<70



MONTREAL (Head office)
 19151 A, Cruickshank Avenue
 Baie-D'Urfé (Québec) H9X 3N9
 Phone: 418 694-4223
 Toll free: 1 866 421-4223
info@elevex.ca
elevex.ca

QUEBEC
 1279, Paul-Émile Giroux St. Suite 200
 Québec (Québec) G1C 0K9

SAGUENAY
 2305, Alexis-Le-Trotteur St.
 Jonquière (Québec) G7X 9H8

