

FORKLIFT TRUCK



SCP130A

STANDARD FEATURES

- ➔ Powered tilting cab for service
- ➔ Backup camera with object detection system
- ➔ Enclosed cab with automatic climate control and with a high back
- ➔ Separate hydraulic and brake oil systems
- ➔ Powerful Cummins engine

28,600 lbs

Rated Load Capacity

38,600 lbs

Weight Without Load

114"

Wheelbase

Cummins Diesel

Engine

DIMENSIONS

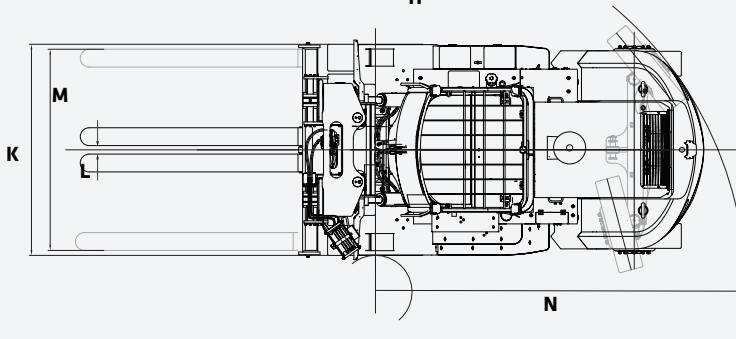
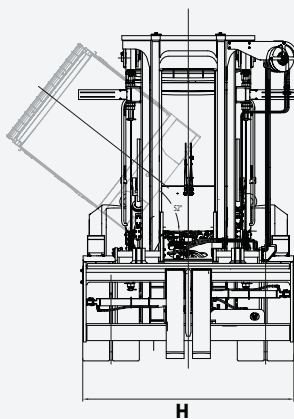
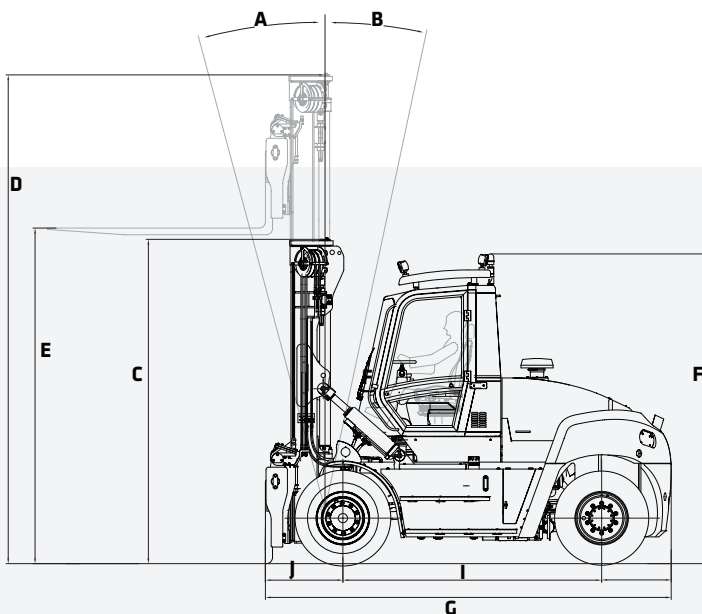

DIMENSIONS

MAST

A	Forward Tilt	12°	
B	Back Tilt	15°	
C	Height Lowered	143"	3 635 mm
D	Height Extended	216"	5 480 mm
E	Lift Height	148"	3 760 mm

OVERALL

F	Cab height	137"	3 470 mm
G	Length to Load Face	179"	4 550 mm
H	Width	93"	2 370 mm
I	Wheelbase	114"	2 900 mm
J	Load Distance	34"	870 mm

FORK

	Thickness	3"	75 mm
	Width	8"	200 mm
	Length	96"	2 440 mm

CARRIAGE

K	Width	93"	2 370 mm
---	-------	-----	----------

FORK SPREAD

L	In-In Minimum	3.7"	95 mm
M	Out-Out Maximum	89"	2 255 mm

GROUND CLEARANCE

	Minimum Ground Clearance	10.4"	264 mm
--	--------------------------	-------	--------

AISLE WIDTH

	With Load Length	302"	7 660 mm
--	------------------	------	----------

TURNING RADIUS

N	Outside	163"	4 150 mm
---	---------	------	----------

In the interest of continual equipment development, SANY Canada Ltd. reserves the right to change these specifications at any time without prior notification.

©2023 SANY Canada Ltd.

STANDARD AND OPTIONAL EQUIPMENT

s = standard / o = optional

SCP130A	ENGINE
s	QSB 4.5l Cummins Diesel with 160HP @ 2300rpm
s	Tier 4 Final EPA Emissions Compliant
s	High Intake, Long Life Air Filter w/ Safety Element
s	Fuel Filter with Water Separator
s	Variable Geometry Turbocharger
s	500-Hr Engine-Oil-Change Interval
s	Electronic Controlled
s	24V, 70A Alternator
DRIVETRAIN	
s	Dana TE-10 Transmission
s	3 FWD & 3 REV gears
s	Kessler D61 Drive Axle
s	Heavy Duty Wet Disc Brakes
s	Electronically Actuated Parking Brake
s	6 x 10.00-20 Pneumatic Tires
MAST	
s	Duplex Mast, MFH 148", OALH 153", EXT 226"
o	Duplex Mast, MFH 148", OALH 143", EXT 216"
o	Duplex Mast, MFH 196", OALH 177", EXT 274"
s	Apron Type Carriage
s	Independent Fork Positioner
s	Side Shift Carriage
s	96" x 7.87" x 2.95" Pin Type Forks
ACCESSORIES	
o	Reverse Camera w/ 7" Color Display
s	Rear Object Detection Sensor up to 10"
s	Common Greasing Points for Steer Axle and Mast
s	Automatic Engine Fire Extinguisher
s	Locking Fuel Cap
o	Travel Speed Limiter
o	Integrated Tire Pressure Monitoring System
o	Extreme Cold Climate Package (Fuel, Engine and Hydraulics)
o	Customized Colors or Labels
s	Lockable Battery Disconnect Switch
o	Steer Wheel Lug Nut Protection
s	Rear Lifting Eyes

STANDARD AND OPTIONAL EQUIPMENT

s = standard / o = optional

SCP130A	OPERATOR'S STATION
s	High Visibility Enclosed Cabin w/ Curved Glass
o	Grammer Air Suspension Cloth Seat
s	Climate Control with A/C and Heat
s	Ergonomic Multifunction Joystick
o	Individual Hydraulic Control Levers
s	Telescoping and Tilting Steering Column
s	Steering Wheel Spinner Knob
o	AM/FM Radio with 2 Speakers and USB Connectivity
s	Front, Rear and Top wiper
s	Top Retractable Sun Shade
s	12V/24V Power Supply
s	Push Button Applied Park Brake
o	Reading Light
s	Exterior Cabin Mounted Mirrors
s	Powered Tilting Cabin for Ease of Maintenance
ELECTRICAL	
s	2 Front Fender Mounted LED Lights
s	2 Front Cab Mounted LED Lights
s	2 Rear Cab Mounted LED Lights
s	2 Mast Mounted LED Working Lights
o	Indicator and Hazard lights
o	Rotating Amber Beacon
o	Additional LED Lights

PRODUCT SPECIFICATIONS FORKLIFT TRUCKS || SCP130A

WORKING RANGE

SPECIFICATIONS		
GENERAL		
Rated Load Capacity	28,600 lbs	13 000 kg
Load Center	24"	600 mm
Load Distance	34"	870 mm
Wheelbase	114"	2 900 mm
Hydraulic Tank Capacity	45 gal	170 l
Fuel Tank Capacity	50 gal	190 l
WEIGHTS		
Total Truck Weight without Load	38,600 lbs	17 500 kg
Axle Loading with Load		
Front	60,800 lbs	27 600 kg
Rear	4,900 lbs	2 200 kg
Axle Loading without Load		
Front	20,100 lbs	9 100 kg
Rear	18,500 lbs	8 400 kg
WHEELS		
Tire Type	Pneumatic	
Tire Size		
Drive	10.00-20 16PR	
Steer	10.00-20 16PR	

LIFTING PERFORMANCE

PERFORMANCE		
SPEED		
Travel		
With Load	18.6 mph	30 km/h
Without Load	19.2 mph	31 km/h
Lifting		
With Load	79 ft/min	0.40 m/s
Without Load	89 ft/min	0.45 m/s
Lowering		
With Load	98 ft/min	0.50 m/s
Without Load	94 ft/min	0.48 m/s
DRAWBAR		
Pull-Max	23,200 lbf	103 kN
GRADEABILITY @ 1 MPH (1.6 KM/H)		
With Load	29%	

In the interest of continual equipment development, SANY Canada Ltd. reserves the right to change these specifications at any time without prior notification.

POWERTRAIN		
ENGINE		
Type	Cummins Diesel	
Emmissions Type	EPA Tier 4 Final	
Output		
Rated	160 hp	119 kW
Peak	230 hp	172 kW
Governed Speed	2,200 rpm	
Cylinders		
Number	4	
Disp	4.5 l	
Turbocharger	Water-cooled variable geometry	
ALTERNATOR		
Amps	24V	70A
Drive Axle	Kessler D61	
Transmission	TE10	
GEARS		
Forward	3	
Reverse	3	
BATTERY		
Capacity	2 x 12 V 120 Ah CCA	
BRAKES		
Service	Wet Disc	
Parking	Dry Disc	
TANK CAPACITY		
DEF	5 gal	19 l
MAST		
Mast Type	Duplex w/o Freelift	
*Height Maximum	148"	3 760 mm
*OALH	143"	3 635 mm
*Extended	216"	5 480 mm
*Freelift	-	-
Fork Type	Pin	
Fork Size	96" x 8" x 3"	
Carriage Type	Apron	

* All imperial numbers have been rounded to the nearest whole number.



MONTREAL (Head office)
19151 A, Cruickshank Avenue
Baie-D'Urfé (Québec) H9X 3N9

Phone: 418 694-4223
Toll free: 1 866 421-4223
info@elevex.ca



QUEBEC
1279, Paul-Émile Giroux St. Suite 200
Québec (Québec) G1C 0K9

SAGUENAY
2305, Alexis-Le-Trotteur St.
Jonquière (Québec) G7X 9H8



elevex.ca