

# FORKLIFT TRUCK

# SCP320H4

**STANDARD FEATURES**

- ➔ Powered sliding cab
- ➔ Backup camera with object detection system
- ➔ Separate brake fluid and hydraulic oil tanks
- ➔ Enclosed cab with automatic climate control and with a high back
- ➔ Powerful Cummins engine

**70,500 lbs**

Rated Load Capacity

**96,600 lbs**

Weight w/o Load

**189"**

Wheelbase

**Cummins Diesel**

Engine

**DIMENSIONS**

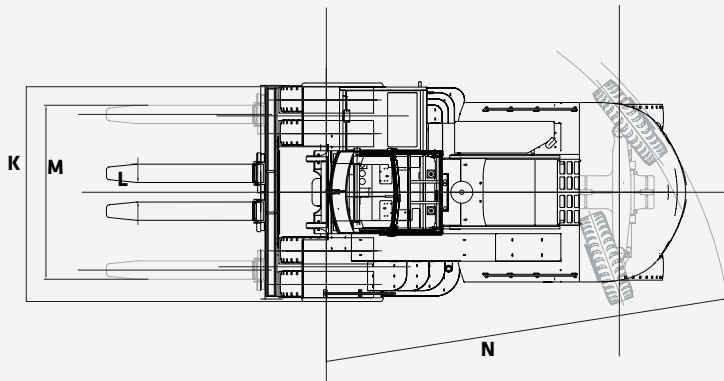
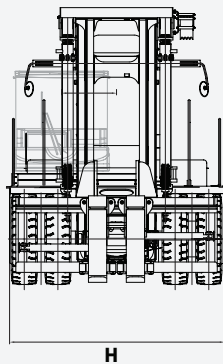
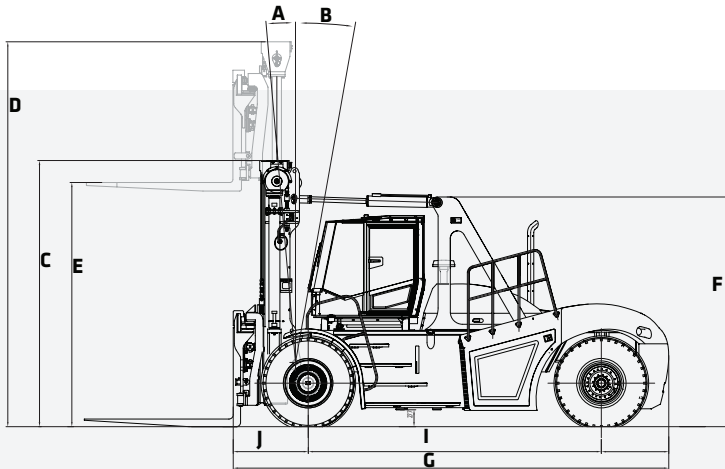

**DIMENSIONS**

**MAST**

A	Forward Tilt	5°	
B	Back Tilt	10°	
C	Height Lowered	172"	4 360 mm
D	Height Extended	248"	6 305 mm
E	Lift Height	157"	3 761 mm

**OVERALL**

F	Tilt Support Height	148"	3 760 mm
G	Length to Load Face	281"	7 125 mm
H	Width	141"	3 580 mm
I	Wheelbase	189"	4 800 mm
J	Load Distance	48"	1 230 mm

**FORK**

	Thickness	5"	125 mm
	Width	12"	300 mm
	Length	96"	2 440 mm

**CARRIAGE**

K	Width	141"	3 580 mm
---	-------	------	----------

**FORK SPREAD**

L	In-In Minimum	13"	320 mm
M	Out-Out Maximum	112"	2 850 mm

**GROUND CLEARANCE**

	Minimum Ground Clearance	12"	300 mm
--	--------------------------	-----	--------

**AISLE WIDTH**

	With Load Length	414"	10 510 mm
--	------------------	------	-----------

**TURNING RADIUS**

N	Outside	262"	6 650 mm
---	---------	------	----------

In the interest of continual equipment development, SANY Canada Ltd. reserves the right to change these specifications at any time without prior notification.  
©2023 SANY Canada Ltd.

s = standard / o = optional

SCP320H4	ENGINE
s	QSB 6.7l Cummins Diesel with 260HP @ 2200rpm
s	Tier 4 Final EPA Emissions Compliant
s	High Intake, Long Life Air Filter w/ Safety Element
s	Fuel Filter with Water Separator
s	Variable Geometry Turbocharger
s	500-Hr Engine-Oil-Change Interval
s	Electronic Controlled
s	24V, 100A Alternator
s	Turbocharger Protection via Engine Shut Off Delay
DRIVETRAIN	
s	Dana TE17 Transmission
s	3 FWD & 3 REV gears
s	Kessler D91 Drive Axle
s	Heavy Duty Wet Disc Brakes
s	Electronically Actuated Parking Brake
s	6 x 16.00-25 Pneumatic Tires
MAST	
s	Duplex Mast, MFH 157", OALH 172", EXT 248"
o	Duplex Mast, Various Heights
s	Hook Type Carriage
s	Apron Type Carriage
s	Independent Fork Positioner
s	Simultaneous Fork Positioner
s	Side Shift Carriage
s	96" x 12" x 5" Pin Type Forks
ACCESSORIES	
o	Reverse Camera w/ 7" Color Display
s	Rear Object Detection Sensor up to 10"
s	Common Greasing Points for Steer Axle and Mast
s	Automatic Engine Fire Extinguisher
s	Locking Fuel Cap
o	Travel Speed Limiter
o	Extreme Cold Climate Package (Fuel, Engine and Hydraulics)
o	Integrated Tire Pressure Monitoring System
o	Customized Colors or Labels
s	Lockable Battery Disconnect Switch
s	Steer Wheel Lug Nut Protection
s	Rear Lifting Eyes

**STANDARD AND OPTIONAL EQUIPMENT**

s = standard / o = optional

<b>SCP320H4 OPERATOR'S STATION</b>	
s	High Visibility Enclosed Cabin w/ Curved Glass
o	Grammer Air Suspension Seat
s	Climate Control with A/C and Heat
s	Ergonomic Multifunction Joystick
o	Individual Hydraulic Control Levers
s	Telescoping and Tilting Steering Column
s	Steering Wheel Spinner Knob
o	Radio and Speaker Ready
s	Front, Rear and Top wiper
s	Top Retractable Sun Shade
s	12V/24V Power Supply
s	Push Button Applied Park Brake
o	Reading Light
s	Exterior Cabin Mounted Mirrors
s	Powered Sliding Cabin for Increased Visibility and Ease of Maintenance
<b>ELECTRICAL</b>	
s	2 Front Fender Mounted LED Lights
s	2 Front Cab Mounted LED Lights
s	2 Rear Cab Mounted LED Lights
s	2 Mast Mounted LED Working Lights
o	Indicator and Hazard lights
o	Rotating Amber Beacon
o	Additional LED Lights

# PRODUCT SPECIFICATIONS FORKLIFT TRUCKS || SCP320H4

## WORKING RANGE

SPECIFICATIONS		
<b>GENERAL</b>		
Rated Load Capacity	70,500 lbs	32 000 kg
Load Center	48"	1 230 mm
Load Distance	48"	1 230 mm
Wheelbase	189"	4 800 mm
Hydraulic Tank Capacity		
Main	87 gal	330 l
Brake	26 gal	100 l
Fuel Tank Capacity	105 gal	400 l
<b>WEIGHTS</b>		
Total Truck Weight w/o Load	96,600 lbs	43 800 kg
Axle Loading with Load		
Front	156,000 lbs	70 700 kg
Rear	11,200 lbs	5 100 kg
Axle Loading without Load		
Front	50,700 lbs	23 000 kg
Rear	45,900 lbs	20 800 kg
<b>WHEELS</b>		
Tire Type	Pneumatic	
Tire Size		
Drive	16.00-25	
Steer	16.00-24	

## LIFTING PERFORMANCE

PERFORMANCE		
<b>SPEED</b>		
Travel		
With Load	15.5 mph	25 km/h
Without Load	17 mph	28 km/h
Lifting		
With Load	49 ft/min	0.25 m/s
Without Load	59 ft/min	0.3 m/s
Lowering		
With Load	79 ft/min	0.4 m/s
Without Load	79 ft/min	0.40 m/s
<b>DRAWBAR</b>		
Pull-Max	39,550 lbf	176 kN
<b>GRADEABILITY @ 1 MPH (1.6 KM/H)</b>		
With Load	21%	

In the interest of continual equipment development, SANY Canada Ltd. reserves the right to change these specifications at any time without prior notification.

POWERTRAIN		
<b>ENGINE</b>		
Type	Cummins Diesel	
Output		
Rated	260 hp	194 kW
Governed Speed	2,200 rpm	
Cylinders		
Number	6	
Disp	6.7 l	
Turbocharger	Water-cooled variable geometry	
<b>ALTERNATOR</b>		
Amps	24V	100A
Drive Axle	Kessler D-91	
Transmission	Dana TE17	
<b>GEARS</b>		
Forward	3	
Reverse	3	
<b>BATTERY</b>		
Capacity	2 x 12 V 165 Ah CCA	
<b>BRAKES</b>		
	Wet Disc	
Parking	Dry Disc	
<b>TANK CAPACITY</b>		
DEF	10 gal	38 l

MAST		
TYPE	Duplex w/o Freelift	
Height *Maximum	157"	4 000 mm
*OALH	172"	4 360 mm
*Extended	248"	6 305 mm
*Freelift	-	-
Fork Type	Pin	
Carriage Type	Hook	

\* All imperial numbers have been rounded to the nearest whole number.  
\* Multiple masts heights available up to 275" lift height.



**MONTREAL (Head office)**  
19151 A, Cruickshank Avenue  
Baie-D'Urfé (Québec) H9X 3N9

Phone: 418 694-4223  
Toll free: 1 866 421-4223  
info@elevex.ca



**QUEBEC**  
1279, Paul-Émile Giroux St. Suite 200  
Québec (Québec) G1C 0K9

**SAGUENAY**  
2305, Alexis-Le-Trotteur St.  
Jonquière (Québec) G7X 9H8



[elevex.ca](http://elevex.ca)